



# WEH<sup>®</sup> Connectors

for pressure-tight connections in seconds  
to threads, tubes, beads, etc.



**To the current  
catalog version:**



© All rights reserved, WEH GmbH Verbindungstechnik.

Any unauthorized copying, distribution, or other use of the copyrighted content is prohibited without the written consent of WEH GmbH Verbindungstechnik.

With the transmission of a more recent version of this document, all older versions lose their validity. The most recent version of the document applies. This can be found at [www.weh.com/downloads](http://www.weh.com/downloads).

Unless expressly agreed otherwise, our General Terms and Conditions and the Know-How Protection and Quality Assurance Agreement ([www.weh.com](http://www.weh.com)) apply to all deliveries and other services.

We do not recognize the customer's general terms and conditions.

WEH® is a registered trademark of WEH GmbH Verbindungstechnik.

## » Table of contents

---

<b>1  </b>	<b>Connection solutions</b>	<b>6</b>
1.1	Introduction	6
1.2	Product overview	8
<b>2  </b>	<b>WEH® Connectors for female threads</b>	<b>10</b>
2.1	TW17	10
2.2	TW19	16
2.3	TW05	20
2.4	TW26	24
2.5	TW03	28
<b>3  </b>	<b>WEH® Connectors for male threads</b>	<b>32</b>
3.1	TW18	32
3.2	TW04	38
<b>4  </b>	<b>WEH® Universal connectors</b>	<b>42</b>
4.1	TW800	42
4.2	TW850	46
4.3	TW130	48
4.4	TW131	50
4.5	TW132	52
4.6	TW141	54
4.7	TW221	58
4.8	TW230	62
4.9	TW241	66
4.10	TW01	72
4.11	TW02	78

## » Table of contents

---

<b>5  </b>	<b>Special connectors</b> .....	<b>82</b>
5.1	Fuel connectors .....	82
5.2	Special solutions .....	83
<b>6  </b>	<b>Further information</b> .....	<b>84</b>
6.1	Technical appendix .....	84
6.2	Brochure data .....	87

## » Impressions

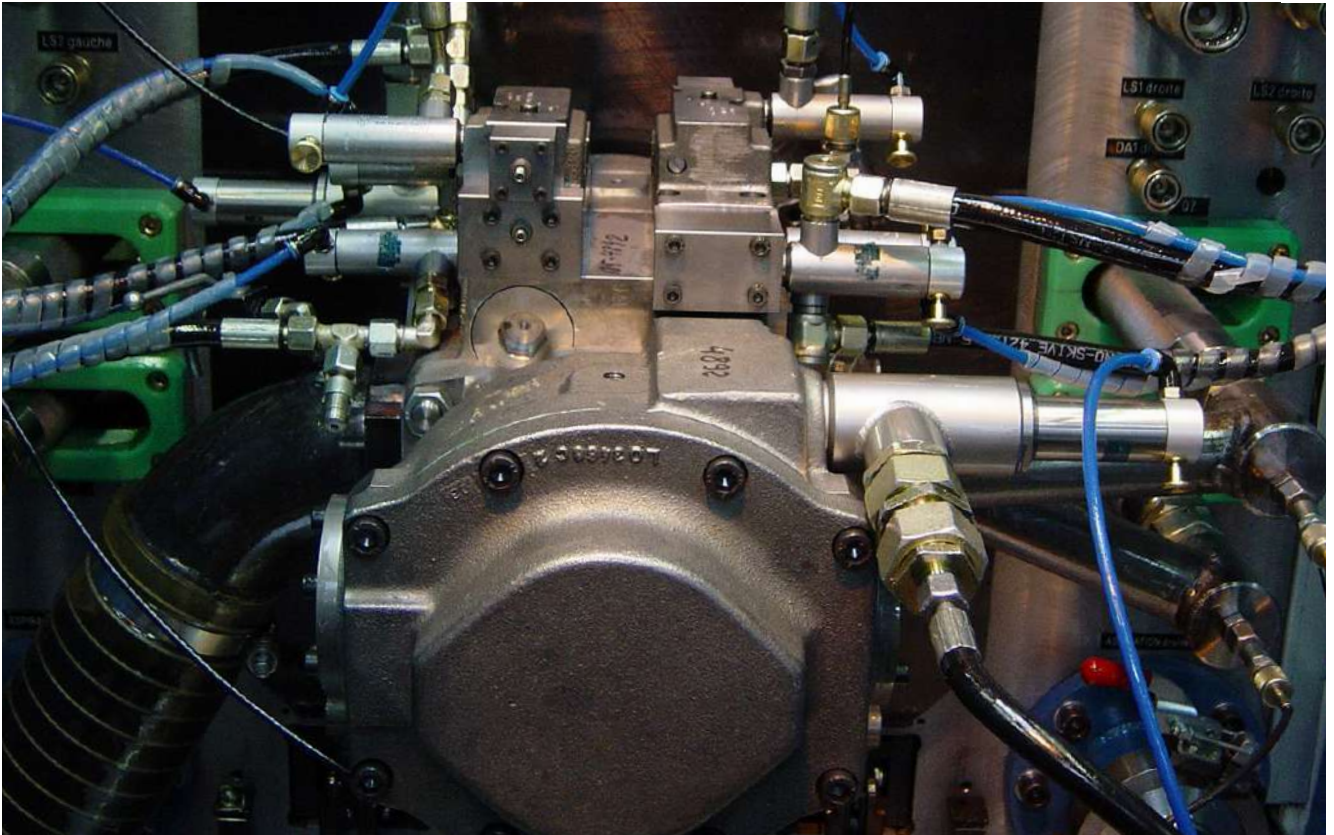

## » Introduction

### WEH® Quick connectors for pressure and function testing, filling and plugging

WEH is one of the leading manufacturers of quick connectors for pressure and function testing. For over 50 years, the unique jaw locking mechanism developed by WEH has represented a leap in the efficiency of leak testing.

#### Extensive connection possibilities

Female or male threads, straight tubes, beads, collars, swages/flares or bores: WEH offers a solution for almost every application where a connection is needed. A suitable testing connector is available for each type of connection. We offer customer-tailored solutions for special applications even from small quantities.



In addition to the benefits the WEH® Jaw locking mechanism offers, you will no longer need pre-mounted coupling systems when using a WEH® Connector. It is not necessary to attach a counterpart to the component to be tested - with the WEH® Connectors you simply connect to the existing ports.

#### Connections in seconds

Pressure testing of components for leak tightness and function, whether manual, pneumatic or fully automatic, must be simple and time-saving. WEH® Connectors are simply placed onto / over or into the inlet of the test piece and the pressure-tight connection is immediate. Laborious thread connections and tightening of pressure test hoses is no longer needed and intricate testing devices are a thing of the past. The WEH® Connectors are designed for pressures up to several 1000 bar depending on connection type and test piece. In comparison to threaded connections there are significant time and cost reductions due to the efficient design of WEH® Connectors.

As a long standing partner to the international automotive, hydraulic and other manufacturing industries, WEH offers advanced solutions to make production processes faster, cost effective and more efficient.

### The original WEH® Jaw locking mechanism For a perfect connection in seconds

A major part of the WEH® Connectors has the unique jaw locking mechanism developed by WEH. Hard wearing jaws clamp securely and safely onto a large variety of different connections, including female and male threads, straight tubes, tube ends and bores among others.

Laborious screwing and unscrewing of hoses is eliminated and the operators' joints are spared. The latest sealing technology provides a pressure-tight connection for your application.



## » Introduction

### Applications

WEH® Quick connectors have become standard in the general industry worldwide. Where all supply lines had to be screwed on engine test benches, now the innovative WEH® Connectors enable pressure-tight connections in seconds.

Increase your productivity using WEH® Connectors and benefit from the significant advantages:

- Safe and pressure-tight connections
- Reduction of connecting times → cost saving
- Ease of operation
- Operators' joints are protected from RSI

Connection solutions for hydraulic, pneumatic and fluid applications include testing of pressure vessels, fluid lines, hydraulic aggregates / hydraulic pumps / hydraulic blocks, pneumatic components, air engines, engines, injector pumps, steering racks, cylinder and automotive components.

### Examples of use



TW723 | Testing of engines

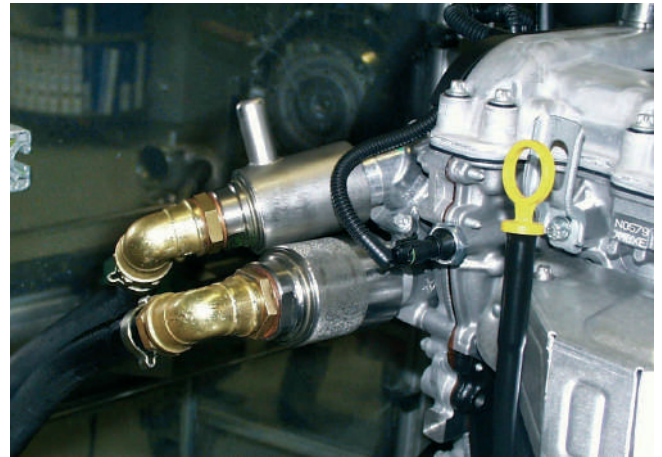

TW800 | Testing of engines



TW17H | Testing of injection pumps

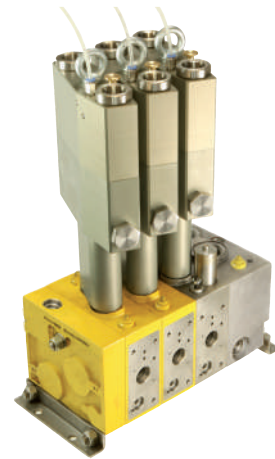

TW17V | 3 x twin connector for testing of hydraulic pumps

## » Product overview

### WEH® Connectors for female threads



TW17



TW19



TW05



TW03



TW26

### WEH® Connectors for male threads



TW18



TW04



TW800



TW850

### WEH® Universal connectors for threads, tubes, beads, etc.



TW800



TW850

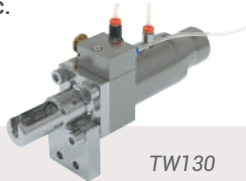

TW130



TW131



TW141



TW221



TW230



TW132



TW01



TW02



TW241

### Special connectors



Fuel connectors



Special solutions

For reasons of precaution, we'd like to point out that

a) regarding the delivery of each article acc. to the respective order confirmation - in particular concerning ECE / EC79 articles - WEH does not confirm the fulfilment of additional requirements of the concerned end customer,

b) WEH is not subject to any external reporting obligation with regard to external change management (see page 84) and

c) WEH does not confirm the replacement of the product in the form of a regular series delivery.

Exclusions acc. to a) - c) can be agreed with the conclusion of a customer-specific project with corresponding special conditions.

## » Connection possibilities

Type	Max. allowable operating pressure bar	Male threads	Female threads	Straight tubes	Holes and bores	Swaged and flared	Beads	Collars	Barbs
									
TW17	350		✓						
TW19	350		✓						
TW05	5 - 12		✓						
TW26	50		✓						
TW03	345		✓						
TW18	350	✓				✓	✓	✓	✓
TW04	50	✓							
TW800	50	✓				✓	✓	✓	✓
TW850	630	✓				✓	✓	✓	✓
TW130	350	✓*	✓*			✓	✓	✓	✓*
TW131	50	✓*	✓*						
TW132	50	✓*	✓*						
TW141	100			✓					
TW221	3			✓	✓	✓		✓	✓
TW230	70			✓	✓	✓		✓	✓
TW241	70			✓					
TW01	9		✓	✓	✓	✓	✓	✓	✓
TW02	35	(✓)		✓		✓	✓	✓	✓

\* The test piece profile must allow a firm grip!

Automation is possible for many types. Please contact us!  
Please note the relevant information on page 84, Technical explanations.

### ORDERING

Normally we need the following information when ordering:

1. Part no.
2. Pressure range
3. Medium / leak rate
4. Description of application
5. Temperature range
6. Space requirement (interference contours, clearance, etc.)
7. CAD drawing of customer test piece with tolerances
8. Test piece

## » WEH® Connector TW17

### DESCRIPTION



#### Features

- Connection in seconds
- No hand tightening required
- WEH® Jaw locking mechanism
- Modified clamping jaws for increased flow
- Ergonomic design
- High-grade materials
- Different actuations
- Automation possible
- Testing devices are eliminated

The WEH® TW17 Quick connector is designed for sealing standardized female thread applications. The higher the test pressure the tighter the WEH® Connector will clamp itself into the thread of the test piece and provides a pressure-tight connection in seconds. The front o-ring reliably seals the connection and no additional clamping devices are required. Time-consuming and expensive testing devices are eliminated.

Bores have been added as standard to the clamping jaws for body sizes 5 - 6 of the WEH® TW17 Connector to increase flow rates.

The WEH® TW17 Connector is available with different actuations:

TW17H - Manual actuation via lever

TW17V - Pneumatic actuation via valve head

TW17P - Pneumatic actuation for external manual, semi or fully automatic control systems

The actuation can be easily changed at any time by simply unscrewing the rear part of the connector and replacing it with the chosen actuation.



TW17 with bores for increased flow

Special versions, e.g. connectors in longer or shorter versions, as a plug or with hydraulic actuation etc. are possible (see special solutions).

#### Application

Quick connector for pneumatic and hydraulic pressure and function testing of components with female thread, e.g. engines, cylinders, pressure vessels, hoses, fixtures, etc.

**Note:** For using the WEH® Connectors with pneumatic actuation and clamping jaws in an automated system please observe the technical explanation on page 84.

### TECHNICAL DATA

Characteristics	Basic version
Max. allowable operating pressure PS	Vacuum up to 350 bar
Pilot pressure	6 - 12 bar compressed air
Pilot pressure port P1	G1/8" female thread
Pilot pressure port P2	G1/4" female thread
Temperature range	+5 °C up to +80 °C
Leak rate	$1 \times 10^{-3}$ mbar x l/s
Actuation	H = manual actuation via lever V = pneumatic actuation via valve head P = pneumatic actuation for external manual, semi or fully automatic control systems
Material	Corrosion resistant stainless steel, anodized aluminum
Sealing material	Front seal of NBR

Other designs on request

#### Example of use:



# » WEH® Connector TW17

## ORDERING | WEH® TW17 Quick connector

approx. dimensions (mm)

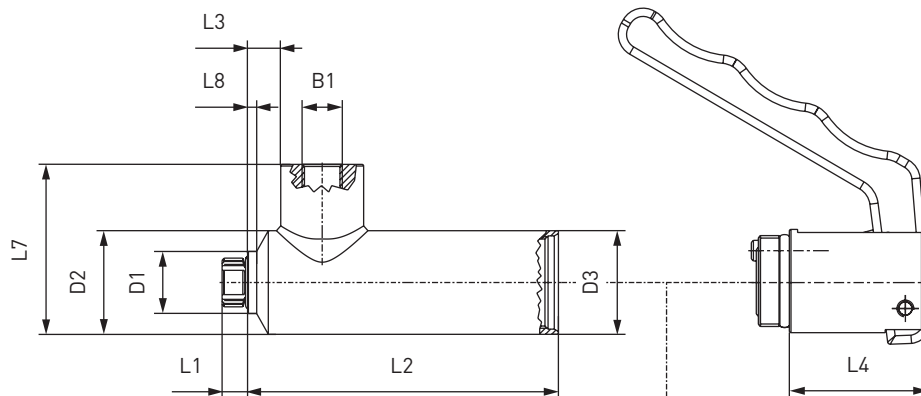

**H**  
Manually by depressing the lever.  
*Medium effort required.*

### Body size 1 - 4

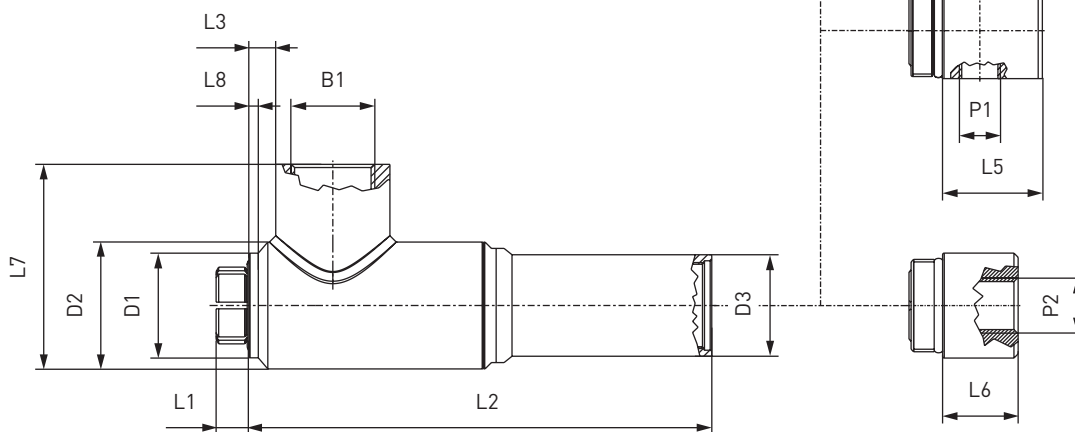

**V**  
Pneumatically by pressing the valve head.  
*Very little effort required.*

**P**  
Pneumatically for external manual, semi or fully automatic control systems

### Body size 5 - 6

Body size	B1 (female thread)	D1	D1*	D2	D2*	D3	L1	L2	L3	L4	L5	L6	L7	L8	L8*
1	G1/8"	15.0	15.0	25.0	25.0	25.0	8.0	75.0	8.0	33.5	24.0	18.0	44.0	2.5	2.5
2	G1/4"	19.0	20.5	27.0	27.0	27.0	9.0	75.0	9.0	32.0	18.0	18.0	40.0	2.5	5.0
3	G3/8"	23.0	26.0	32.0	32.0	32.0	12.0	88.0	9.5	35.0	18.0	18.0	50.0	2.0	4.0
4	G1/2"	27.0	29.0	37.0	37.0	37.0	12.0	88.0	8.0	35.0	18.0	18.0	55.0	3.0	4.0
5	G3/4"	33.0	40.5	40.0	45.0	32.0	14.0	145.0	8.0	35.0	18.0	18.0	68.5	3.0	8.0
6	G1"	40.0	46.5	49.0	49.0	32.0	14.0	168.0	18.0	35.0	18.0	18.0	77.0	3.0	5.0

\* applies to SAE J1926

## » WEH® Connector TW17

Metric ISO thread to DIN 13 - acc. to DIN 3852 part 1, form X and Y

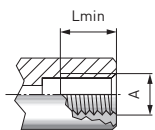

Part no.	Body size	Thread A (female thread)	Lmin*
TW17...-W9031-025	1	M10x1.0	7.0
TW17...-W9033-045	2	M12x1.0	9.5
TW17...-W9034-045	2	M12x1.5	9.5
TW17...-W9035-045	2	M14x1.5	9.5
TW17...-W9036-065	3	M16x1.5	10.5
TW17...-W9037-065	3	M18x1.5	10.5
TW17...-W9038-085	4	M20x1.5	10.5
TW17...-W9039-085	4	M22x1.5	10.5
TW17...-W9040-125	5	M24x1.5	11.0
TW17...-W9043-125	5	M26x1.5	11.0
TW17...-W9044-125	5	M27x2,0	11.0
TW17...-W9045-165	6	M28x1,5	12.5
TW17...-W9046-165	6	M30x1,5	12.5
TW17...-W9070-165	6	M33x2,0	12.5

\* Lmin: minimum thread length  
Other connection sizes on request

Metric ISO thread to DIN 13 - acc. to ISO 6149-1

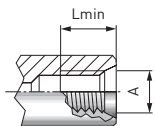

Part no.	Body size	Thread A (female thread)	Lmin*
TW17...-W9082-025	1	M10x1.0	7.0
TW17...-W9083-045	2	M12x1.5	9.5
TW17...-W9084-045	2	M14x1.5	9.5
TW17...-W9085-065	3	M16x1.5	10.5
TW17...-W9086-065	3	M18x1.5	10.5
TW17...-W9133-085	4	M20x1.5	10.5
TW17...-W9087-085	4	M22x1.5	10.5
TW17...-W9092-125	5	M27x2.0	11.0
TW17...-W9115-165	6	M30x2,0	12.5

\* Lmin: minimum thread length  
Other connection sizes on request

## » WEH<sup>®</sup> Connector TW17

Whitworth tube thread to DIN EN ISO 228-1 - acc. to DIN 3852 part 2, form X and Y

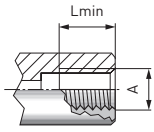

Part no.	Body size	Thread A (female thread)	Lmin*
TW17...-W9000-025	1	G1/8"	7.0
TW17...-W9001-045	2	G1/4"	9.5
TW17...-W9002-065	3	G3/8"	10.5
TW17...-W9003-085	4	G1/2"	10.5
TW17...-W9004-085	4	G5/8"	10.5
TW17...-W9005-125	5	G3/4"	11.0
TW17...-W9006-165	6	G1"	12.5

\* Lmin: minimum thread length  
Other connection sizes on request

BSPT (tapered Whitworth tube thread) - acc. to DIN 3852 part 2, form X and Y

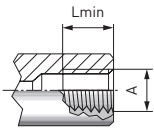

Part no.	Body size	Thread A (female thread)	Lmin*
TW17...-W9024-025	1	BSPT 1/8"	7.0
TW17...-W9025-045	2	BSPT 1/4"	9.5
TW17...-W9026-065	3	BSPT 3/8"	10.5
TW17...-W9027-085	4	BSPT 1/2"	10.5
TW17...-W9028-085	4	BSPT 5/8"	10.5
TW17...-W9029-125	5	BSPT 3/4"	11.0
TW17...-W9030-165	6	BSPT 1"	12.5

\* Lmin: minimum thread length  
Other connection sizes on request

NPT thread (ANSI/ASME B1.20.1-1983) - acc. to SAE J476a

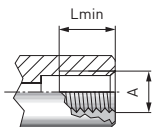

Part no.	Body size	Thread A (female thread)	Lmin*
TW17...-W9007-025	1	NPT 1/8"	7.0
TW17...-W9008-045	2	NPT 1/4"	9.5
TW17...-W9009-065	3	NPT 3/8"	10.5
TW17...-W9010-085	4	NPT 1/2"	10.5
TW17...-W9012-125	5	NPT 3/4"	11.0
TW17...-W9013-165	6	NPT 1"	12.5

\* Lmin: minimum thread length  
Other connection sizes on request

## » WEH® Connector TW17

SAE-O-Ring Boss - acc. to SAE J1926 / ISO 11926

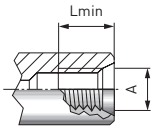

Part no.	Body size	Thread A (female thread)	Lmin*
TW17...-W9078-025	1	UNF 3/8"-24	7.0
TW17...-W9047-025	1	UNF 7/16"-20	7.0
TW17...-W9048-045	2	UNF 1/2"-20	9.5
TW17...-W9049-045	2	UNF 9/16"-18	9.5
TW17...-W9052-065	3	UNF 3/4"-16	10.5
TW17...-W9053-085	4	UNF 7/8"-14	10.5
TW17...-W9055-125	5	UN 1 1/16"-12	11.0
TW17...-W9057-165	6	UN 1 3/16"-12	11.0
TW17...-W9056-165	6	UN 1 5/16"-12	11.0

\* Lmin: minimum thread length  
Other connection sizes on request

Other connection types on request.

Required information for ordering see page 9.

When ordering WEH® TW17 please indicate in addition to the details requested on page 7 the following information:

### 1. Part no.

Please insert within the part no. the letter corresponding to the desired type of actuation (H, V or P) in place of the position indicator (...)

Example: TW17H-W9031-025

### 2. Pressure range

Please add LP = low pressure version (up to 50 bar) or HP = high pressure version (up to 350 bar) at the end of the part number.

Example: TW17H-W9031-025/HP

## » WEH® Connector TW17

### ACCESSORIES

The following accessories are available for the WEH® TW17 Quick connector:

#### Screw plug for plug version

If the WEH® Connector is to be used as a plug, the media inlet 'B1' can be sealed with a screw plug of brass with a PVC sealing ring for low pressure range or alternatively of stainless steel with an o-ring of NBR 70° Shore for high pressure range. It is recommended that the media compatibility of the seal be tested by the customer!

Low pressure



High pressure

Part no.	Description	Connection (male thread)	Pressure range
<b>E69-9200</b>	Screw plug (low pressure)	G1/8"	0 - 50 bar
<b>E69-9210</b>	Screw plug (low pressure)	G1/4"	0 - 50 bar
<b>E69-9220</b>	Screw plug (low pressure)	G3/8"	0 - 50 bar
<b>E69-9230</b>	Screw plug (low pressure)	G1/2"	0 - 50 bar
<b>W9338</b>	Screw plug (low pressure)	G3/4"	0 - 50 bar
<b>W9329</b>	Screw plug (high pressure)	G1/8"	0 - 350 bar
<b>W9330</b>	Screw plug (high pressure)	G1/4"	0 - 350 bar
<b>W9331</b>	Screw plug (high pressure)	G3/8"	0 - 350 bar
<b>W9332</b>	Screw plug (high pressure)	G1/2"	0 - 350 bar
<b>W9333</b>	Screw plug (high pressure)	G3/4"	0 - 350 bar
<b>W9334</b>	Screw plug (high pressure)	G1"	0 - 350 bar
<b>W9335</b>	Screw plug (high pressure)	G1 1/4"	0 - 350 bar

### SPECIAL SOLUTIONS

Examples:



TW17P with extension



TW17V twin connector



TW17V multiple connector

## » WEH® Connector TW19

### DESCRIPTION



#### Features

- Connection in seconds
- No hand tightening required
- WEH® Jaw locking mechanism
- High-grade materials

The WEH® TW19 Quick connector is especially designed for sealing hydraulic components with female thread in high and low pressure applications.

The clamping lever actuated connector safely grips into the test piece, even in case of high lateral forces, e.g. heavy or rigid hoses. The higher the test pressure the tighter the WEH® Connector will clamp itself into the thread of the test piece.

The front o-ring reliably seals the connection and no additional clamping devices are required.

Having only one seal in the interior of the connector, ease of maintenance is provided.

#### Application

Quick connector for pneumatic and oil-hydraulic pressure and function testing of components with female thread, e.g. hydraulic aggregates.

### TECHNICAL DATA

Characteristics	Basic version
Max. allowable operating pressure PS	Vacuum up to 350 bar
Temperature range	+5 °C up to +80 °C
Leak rate	$1 \times 10^{-3}$ mbar x l/s
Actuation	Manual actuation via clamping lever
Material	Corrosion resistant stainless steel
Sealing material	Front seal of NBR

Other designs on request

**Note:** Please contact us when using corrosive media or water!

#### Example of use:



# » WEH® Connector TW19

## ORDERING | WEH® TW19 Quick connector

approx. dimensions (mm)

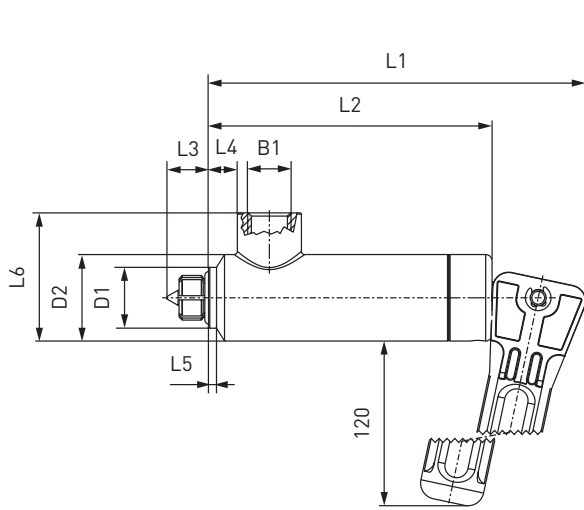

Body size 2 - 4

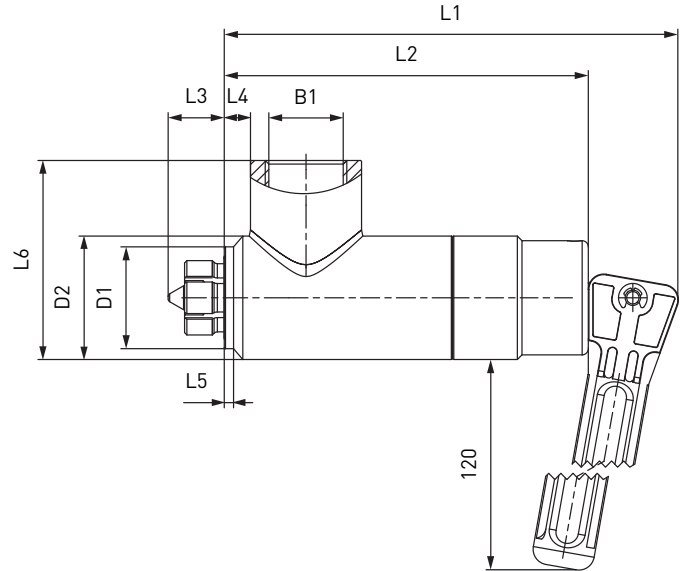

Body size 5 - 6

Body size	B1 (female thread)	D1	D1*	D2	D2*	L1	L2	L3	L4	L5	L5*	L6
2	G1/4"	19.0	20.5	27.0	27.0	118.0	88.5	13.0	9.0	2.5	5.0	40.0
3	G3/8"	23.0	26.0	32.0	32.0	131.0	101.5	16.0	9.5	2.0	4.0	50.0
4	G1/2"	27.0	29.0	37.0	37.0	131.0	101.5	17.0	8.0	3.0	4.0	55.0
5	G3/4"	33.0	40.5	40.0	45.0	146.0	117.0	19.5	8.0	3.0	8.0	69.0
6	G1"	40.0	46.5	49.0	49.0	170.0	140.0	17.0	18.0	3.0	8.0	74.0

\* applies to SAE J1926

Metric ISO-thread to DIN 13 - acc. to DIN 3852 part 1, form X and Y

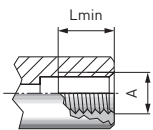

Part no.	Body size	Thread A (female thread)	Lmin*
<b>C1-16484</b>	2	M12x1.5	9.5
<b>C1-16483</b>	2	M14x1.5	9.5
<b>C1-16590</b>	3	M16x1.5	10.5
<b>C1-16459</b>	3	M18x1.5	10.5
<b>C1-18404</b>	4	M20x1.5	10.5
<b>C1-16460</b>	4	M22x1.5	10.5
<b>C1-12860</b>	5	M24x1.5	11.0
<b>C1-17260</b>	5	M26x1.5	11.0
<b>C1-14605</b>	6	M30x1,5	12.5

\* Lmin: minimum thread length  
Other connection sizes on request

## » WEH® Connector TW19

Metric ISO thread to DIN 13 - acc. to ISO 6149-1

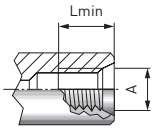

Part no.	Body size	Thread A (female thread)	Lmin*
<b>C1-35915</b>	2	M12x1.5	9.5
<b>C1-14940</b>	2	M14x1.5	9.5
<b>C1-48588</b>	3	M16x1.5	10.5
<b>C1-35916</b>	3	M18x1.5	10.5
<b>C1-119114</b>	4	M20x1.5	10.5
<b>C1-33703</b>	4	M22x1.5	10.5
<b>C1-41186</b>	5	M27x2.0	11.0
<b>C1-187479</b>	6	M27x2,0	11.0

\* Lmin: minimum thread length  
Other connection sizes on request

Whitworth tube thread to DIN EN ISO 228-1 - acc. to DIN 3852 part 2, form X and Y

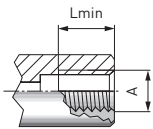

Part no.	Body size	Thread A (female thread)	Lmin*
<b>C1-16494</b>	2	G1/4"	9.5
<b>C1-16493</b>	3	G3/8"	10.5
<b>C1-16888</b>	4	G1/2"	10.5
<b>C1-187460</b>	4	G5/8"	10.5
<b>C1-15161</b>	5	G3/4"	11.0
<b>C1-18191</b>	6	G1"	12.5

\* Lmin: minimum thread length  
Other connection sizes on request

BSPT (tapered Whitworth tube thread) - acc. to DIN 3852 part 2, form X and Y

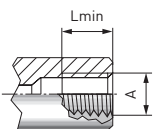

Part no.	Body size	Thread A (female thread)	Lmin*
<b>C1-14544</b>	2	BSPT 1/4"	9.5
<b>C1-18648</b>	3	BSPT 3/8"	10.5
<b>C1-17275</b>	4	BSPT 1/2"	10.5
<b>C1-169262</b>	5	BSPT 3/4"	11.0
<b>On request</b>	6	BSPT 1"	12.5

\* Lmin: minimum thread length  
Other connection sizes on request

## » WEH<sup>®</sup> Connector TW19

NPT thread (ANSI/ASME B1.20.1-1983) - acc. to SAE J476a

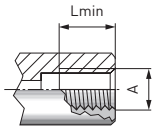

Part no.	Body size	Thread A (female thread)	Lmin*
<b>C1-16565</b>	2	NPT 1/4"	9.5
<b>C1-44258</b>	3	NPT 3/8"	10.5
<b>C1-72165</b>	4	NPT 1/2"	10.5
<b>C1-187461</b>	4	NPT 5/8"	10.5
<b>C1-164869</b>	5	NPT 3/4"	11.0
<b>C1-171955</b>	6	NPT 1"	12.5

\* Lmin: minimum thread length  
Other connection sizes on request

SAE-O-Ring Boss - acc. to SAE J1926 / ISO 11926

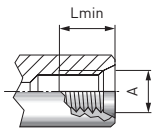

Part no.	Body size	Thread A (female thread)	Lmin*
<b>C1-164843</b>	2	UNF 1/2"-20	9.5
<b>C1-16485</b>	2	UNF 9/16"-18	9.5
<b>C1-17618</b>	3	UNF 3/4"-16	10.5
<b>C1-18242</b>	4	UNF 7/8"-14	10.5
<b>C1-18394-X1</b>	5	UN 1 1/16"-12	11.0
<b>C1-16461</b>	6	UN 1 5/16"-12	11.0

\* Lmin: minimum thread length  
Other connection sizes on request

Other connection types on request.

Required information for ordering see page 9.

### ACCESSORIES

The following accessories are available for the WEH<sup>®</sup> TW19 Quick connector:

Screw plug for plug version (see page 15)

### SPECIAL SOLUTIONS

Examples:



TW19 with parallel clamping lever



TW19 short version with V-actuation



TW19 with 45° lateral port and location lug

## » WEH® Connector TW05

### DESCRIPTION



#### Features

- Connection in seconds
- No hand tightening required
- WEH® Jaw locking mechanism
- Simple seal replacement
- Ergonomic design
- Compact design
- High-grade materials
- Automation possible

With the WEH® TW05 Quick connector pneumatic components are tested faster than ever before. Connecting and pressure impacting of the test piece is accomplished in one operation by simple actuation of the sliding sleeve. In this way, costly testing times are shortened and the quick connector pays for itself in a very short time.

#### Application

Quick connector for pneumatic pressure and function testing of components with female thread, e.g. cylinders, valves, fixtures, pivot drives etc.

**Note:** For using the WEH® Connectors with pneumatic actuation and clamping jaws in an automated system please observe the technical explanation on page 83.

### TECHNICAL DATA

Characteristics	Basic version
Min. operating pressure	5 bar
Max. allowable operating pressure PS	12 bar
Temperature range	+5 °C up to +80 °C
Leak rate	$1 \times 10^{-3}$ mbar x l/s
Material	Clamping jaws: corrosion-resistant stainless steel Outer parts: anodized aluminum
Sealing material	Front seal of NBR

Other designs on request

#### Example of use:

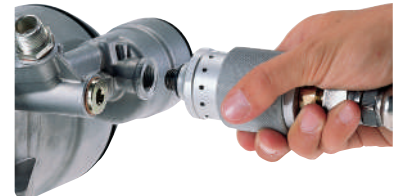

# » WEH<sup>®</sup> Connector TW05

## ORDERING | WEH<sup>®</sup> TW05 Quick connector

approx. dimensions (mm)

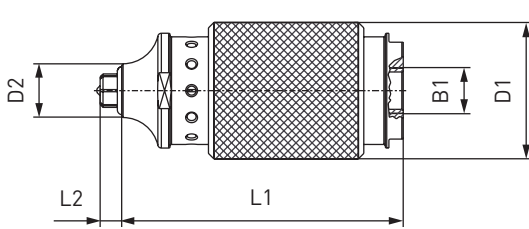

Body size 0 -4

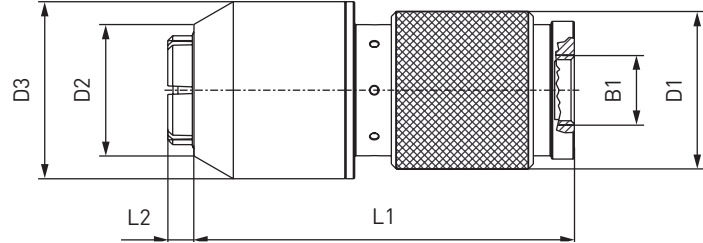

Body size 5 -6

Body size	B1 (female thread)	D1	D2	D3	L1	L2
1	G1/4"	38.0	15.0	-	78.5	6.0
2	G1/4"	38.0	19.0	-	78.5	6.0
3	G1/2"	48.0	23.5	-	82.5	6.5
4	G1/2"	48.0	27.0	-	83.0	6.0
5	G1/2"	48.0	32.0	54.0	115.0	9.0
6	G1/2"	48.0	40.0	54.0	116.0	8.0

Metric ISO thread to DIN 13 - acc. to DIN 3852 part 1, form X and Y

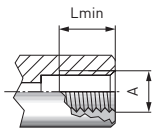

Part No.	Body size	Thread A (female thread)	Lmin*
TW05-W8012-045	1	M8x1.0	7.0
TW05-W8013-045	1	M10x1.0	7.0
TW05-W8042-045	1	M10x1.5	7.0
TW05-W8014-045	2	M12x1.0	9.5
TW05-W8015-045	2	M12x1.5	9.5
TW05-W8041-045	2	M12x1.75	9.5
TW05-W8039-045	2	M14x1.0	9.5
TW05-W8016-045	2	M14x1.5	9.5
TW05-W8017-085	3	M16x1.5	10.5
TW05-W8018-085	3	M18x1.5	10.5
TW05-W8019-085	4	M20x1.5	10.5
TW05-W8020-085	4	M22x1.5	10.5
TW05-W8021-085	5	M24x1.5	11.0
TW05-W8040-085	6	M30x1.5	12.5

\* Lmin: minimum thread length

## » WEH® Connector TW05

Whitworth tube thread to DIN EN ISO 228-1 - acc. to DIN 3852 part 2, form X and Y

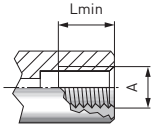

Part no.	Body size	Thread A (female thread)	Lmin*
TW05-W8000-045	1	G1/8"	7.0
TW05-W8001-045	2	G1/4"	9.5
TW05-W8002-085	3	G3/8"	10.5
TW05-W8003-085	4	G1/2"	10.5
TW05-W8004-085	5	G3/4"	11.0
TW05-W8005-085	6	G1"	12.5

\* Lmin: minimum thread length  
Other connection sizes on request

BSPT (tapered Whitworth tube thread) - acc. to DIN 3852 part 2, form X and Y

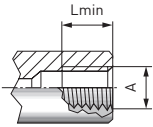

Part No.	Body size	Thread A (female thread)	Lmin*
TW05-W8043-045	1	BSPT 1/8"	7.0
TW05-W8044-045	2	BSPT 1/4"	9.5
TW05-W8038-085	3	BSPT 3/8"	10.5
TW05-W8045-085	4	BSPT 1/2"	10.5
TW05-W8053-085	5	BSPT 3/4"	11.0
TW05-W8047-085	6	BSPT 1"	12.5

\* Lmin: minimum thread length

NPT thread (ANSI/ASME B1.20.1-1983) - acc. to SAE J476a

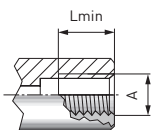

Part no.	Body size	Thread A (female thread)	Lmin*
TW05-W8006-045	1	NPT 1/8"	7.0
TW05-W8007-045	2	NPT 1/4"	9.5
TW05-W8008-085	3	NPT 3/8"	10.5
TW05-W8009-085	4	NPT 1/2"	10.5
TW05-W8010-085	5	NPT 3/4"	11.0
TW05-W8011-085	6	NPT 1"	12.5

\* Lmin: minimum thread length  
Other connection sizes on request

## » WEH® Connector TW05

SAE-O-Ring Boss - acc. to SAE J1926 / ISO 11926

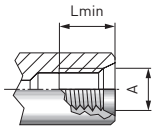

Part No.	Body size	Thread A (female thread)	Lmin*
<b>TW05-W8030-045</b>	1	UNF 7/16"-20	7.0
<b>TW05-W8031-045</b>	2	UNF 1/2"-20	9.5
<b>TW05-W8032-045</b>	2	UNF 9/16"-18	9.5
<b>TW05-W8033-085</b>	3	UNF 3/4"-16	10.5
<b>TW05-W8034-085</b>	4	UNF 7/8"-14	10.5
<b>TW05-W8035-085</b>	5	UN 1 1/16"-12	11.0
<b>TW05-W8036-085</b>	6	UN 1 3/16"-12	11.0
<b>TW05-W8037-085</b>	6	UN 1 5/16"-12	11.0

\* Lmin: minimum thread length

Other connector sizes and versions on request.

Required information for ordering see page 7.

### ACCESSORIES

The following accessories are available for the WEH® TW05:

#### Control housing for automation

A control housing for automatic testing is also available for the TW05 as an alternative to the sliding sleeve.



Part No.	Description
<b>E01-50292</b>	Control housing for automation (body size 1)

### SPECIAL SOLUTIONS

Examples:



TW05 with extension

## » WEH® Connector TW26

### DESCRIPTION



#### Features

- Connection in seconds
- No hand tightening required
- WEH® Jaw locking mechanism
- Simple, inexpensive seal replacement
- Testing devices are eliminated
- Compact design
- High-grade materials

#### Special short design

The WEH® TW26 Quick connector is ideal for hydraulic and pneumatic pressure and function tests on components with female thread. The higher the test pressure the tighter the WEH® Connector will clamp itself into the thread of the test piece and provides a pressure-tight connection in seconds. The front o-ring reliably seals the connection and no additional clamping devices are required. Time-consuming and expensive testing devices are eliminated.

The main advantages of the WEH® TW26 Connector is its compact construction and ergonomic design.

If the connector is to be used as a plug, the media inlet 'B1' can be sealed.

#### Application

Quick connector for pneumatic and hydraulic pressure and function testing with liquid and gaseous media of components with female thread.

**Note:** For using the WEH® Connectors with pneumatic actuation and clamping jaws in an automated system please observe the technical note on page 89.

### TECHNICAL DATA

Characteristics	Basic version
Operating pressure PS	Max. 50 bar
Pilot pressure	6 - 12 bar compressed air
Pilot pressure port P1	G1/8" female thread
Temperature range	+5 °C up to +80 °C
Leak rate	$1 \times 10^{-3}$ mbar x l/s
Actuation	Pneumatic actuation
Material	Corrosion resistant
Sealing material	NBR
Design	Without fittings
Conformity / Tests / Approvals	PED 2014/68/EC

Other designs on request

#### Example of use:

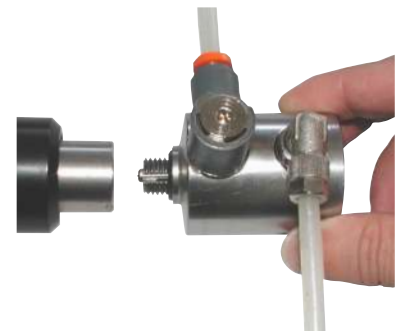

# » WEH® Connector TW26

## ORDERING | WEH® TW26 Quick connector

approx. dimensions (mm)

Body size 1 - 4

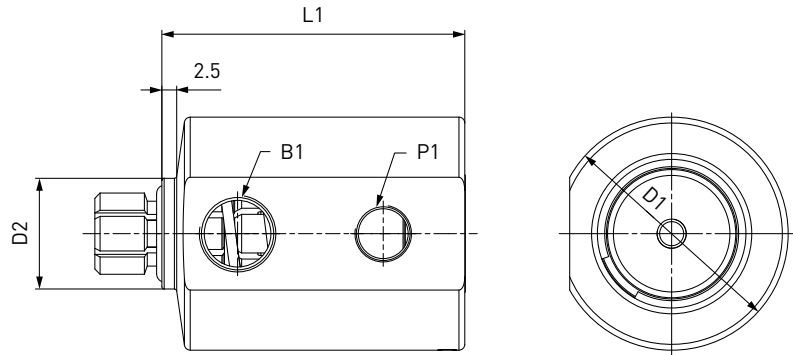

Body size 5

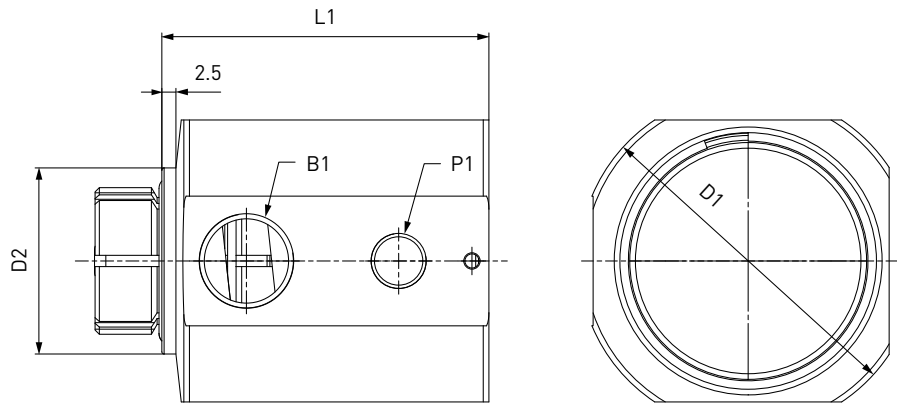

Body size	Inlet B1 (female thread)	D1	D2	L1
1	G1/4"	40.0	15.0	52.0
2	G1/4"	40.0	19.0	52.0
3*	G1/4"	40.0	23.0	55.5
3**	G3/8"	40.0	23.0	55.5
4	G3/8"	40.0	26.0	55.5
5	G3/8"	60.0	33.0	58.0

\* applies to metric threads

\*\* applies to Whitworth tube threads

## » WEH® Connector TW26

Metric ISO thread to DIN 13 - acc. to DIN 3852 part 1, form X and Y

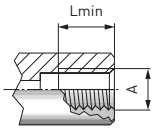

Part No.	Body size	Thread A (female thread)	Lmin*
<b>C1-34098</b>	1	M10x1.0	7.0
<b>C1-119213</b>	2	M12x1.5	11.5
<b>C1-119214</b>	2	M14x1.5	11.5
<b>C1-119215</b>	3	M16x1.5	12.0
<b>C1-16356-X1</b>	3	M18x1.5	11.0
<b>On request</b>	4	M20x1.5	11.0
<b>C1-66154</b>	5	M26x1.5	12.0

\* Lmin: minimum thread length

Whitworth tube thread to DIN EN ISO 228-1 - acc. to DIN 3852 part 2, form X and Y

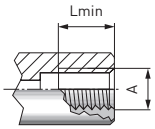

Part No.	Body size	Thread A (female thread)	Lmin*
<b>C1-172942</b>	1	G1/8"	7.0
<b>C1-11761</b>	2	G1/4"	11.5
<b>C1-180353</b>	3	G3/8"	12.0
<b>C1-11763</b>	4	G1/2"	11.0
<b>C1-103944</b>	5	G3/4"	12.0

\* Lmin: minimum thread length

Other connector sizes and versions on request.

Required information for ordering see page 9.

## » WEH<sup>®</sup> Connector TW26

### ACCESSORIES

The following accessories are available for the WEH<sup>®</sup> TW26:

#### Actuation and media control valve

The TW26 is also available with pneumatic actuation for automated applications. We recommend the use of our control valve with push button and inlets for both pilot and test pressures.

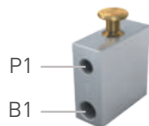

Part No.	Description	Connection B1 (female thread)	Connection P1 (female thread)
<b>W6441</b>	Control housing with V-valve	G1/4"	G1/8"
<b>W56201</b>	Control housing with V-valve	G3/8"	G1/8"

## » WEH® Connector TW03

### DESCRIPTION



#### Features

- Pressure-tight connections by hand-tightening
- Simple seal replacement
- Ergonomic design
- High-grade materials

The WEH® TW03 Quick connector is especially designed for testing components with female threads. Only hand-tighten the connector into the thread until the o-ring seal contacts the test piece. The TW03 seals without wrenches, sealants or tape. NBR seals meet most industrial requirements. In addition to our standard version, we also offer customer-tailored solutions, as for example TW03 with swivel joint, for sealing on round surfaces or for higher pressure ranges up to 700 bar. Please contact us!

#### Application

Quick connector for pressure and vacuum testing of components with female thread, e.g. fittings, fixtures, tubes, boilers, tanks, radiators, etc.

### TECHNICAL DATA

Characteristics	Basic version
Max. allowable operating pressure PS	Vacuum up to 345 bar
Temperature range	+5 °C up to +80 °C
Leak rate	$1 \times 10^{-3}$ mbar x l/s
Material	Corrosion resistant stainless steel
Sealing material	Front seal of NBR

Other designs on request

#### Example of use:



## » WEH<sup>®</sup> Connector TW03

### ORDERING | WEH<sup>®</sup> TW03 Quick connector

approx. dimensions (mm)

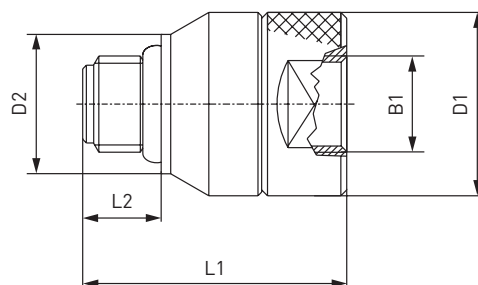

Body size	B1 (female thread)	D1	D2	L1	L2
1	G1/8"	20.5	15.0	33.0	10.5
2	G1/4"	25.0	19.0	36.0	11.0
3	G3/8"	30.0	22.0	39.5	11.0
4	G1/2"	35.0	28.0	47.5	14.5
5	G3/4"	43.0	38.0	50.5	16.0
6	G1"	50.0	44.0	60.0	18.0
7	G1 1/4"	60.0	54.0	55.0	19.5
8	G1 1/2"	70.0	61.0	62.0	19.5
9	G1 1/2"	82.0	73.5	70.0	21.0

## » WEH® Connector TW03

Metric ISO thread to DIN 13 - acc. to DIN 3852 part 1, form X and Y

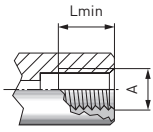

Part no.	Body size	Thread A (female thread)	Max. operating pressure (PS)	Lmin*
C1-12116	1	M10x1.0	345 bar	7.0
C1-187465	1	M10x1.5	345 bar	7.0
C1-187469	2	M12x1.0	345 bar	7.0
C1-12124	2	M12x1.5	345 bar	9.5
C1-12126	2	M14x1.5	345 bar	9.5
C1-12061	3	M16x1.5	276 bar	10.5
C1-12130	3	M18x1.5	276 bar	10.5
C1-12133	4	M20x1.5	276 bar	10.5
C1-12135	4	M22x1.5	276 bar	10.5
C1-12138	5	M24x1.5	276 bar	11.0
C1-12140	5	M26x1.5	276 bar	11.0

\* Lmin: minimum thread length  
Other connection sizes on request

Whitworth tube thread to DIN EN ISO 228-1 - acc. to DIN 3852 part 2, form X and Y

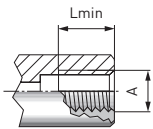

Part no.	Body size	Thread A (female thread)	Max. operating pressure PS	Lmin*
C1-11821	1	G1/8"	345 bar	7.0
C1-11824	2	G1/4"	345 bar	9.5
C1-11827	3	G3/8"	276 bar	10.5
C1-11830	4	G1/2"	276 bar	10.5
C1-11833	5	G3/4"	276 bar	11.0
C1-11836	6	G1"	276 bar	12.5
C1-11839	7	G1 1/4"	276 bar	19.5
C1-11842	8	G1 1/2"	210bar	19.5
C1-17162-X1	9	G2" IG	172 bar	21.0

\* Lmin: minimum thread length  
Other connection sizes on request

NPT thread (ANSI/ASME B1.20.1-1983) - acc. to SAE J476a

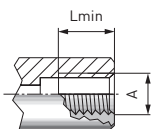

Part no.	Body size	Thread A (female thread)	Max. operating pressure PS	Lmin*
C1-12224	1	NPT 1/8"	345 bar	7.0
C1-12233	2	NPT 1/4"	345 bar	9.5
C1-12235	3	NPT 3/8"	276 bar	10.5
C1-12239	4	NPT 1/2"	276 bar	10.5
C1-12240	5	NPT 3/4"	276 bar	11.0
C1-12242	6	NPT 1"	276 bar	12.5

\* Lmin: minimum thread length  
Other connection sizes on request

Other connection types on request.

Required information for ordering see page 9.

## » WEH<sup>®</sup> Connector TW03

---

### ACCESSORIES

---

The following accessories are available for the WEH<sup>®</sup> TW03 Quick connector:

Screw plug for plug version (see page 15)

### SPECIAL SOLUTIONS

---

Examples:



TW03 with extension

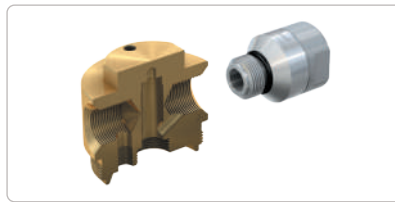

TW03 for round surfaces



TW03 with 90° side connection



TW03 with swivel joint



TW03 as plug

## » WEH® Connector TW18

### DESCRIPTION



#### Features

- Connection in seconds
- No hand tightening required
- WEH® Jaw locking mechanism
- Ergonomic design
- High-grade materials
- Different actuations
- Automation possible
- Testing devices are eliminated

The WEH® TW18 Quick connector establishes pressure-tight connections to components with male thread within seconds. Only place the connector onto the thread of the test piece, the clamping jaws grip on the thread and a pressure-tight connection is made.

The WEH® TW18 Connector is available with different actuations:

TW18H - Manual actuation via lever

TW18V - Pneumatic actuation via valve head

TW18P - Pneumatic actuation for external manual, semi or fully automatic control systems

The actuation can be easily changed at any time by simply unscrewing the rear part of the connector and replacing it with the chosen actuation.

#### Application

Quick connector for pneumatic and hydraulic pressure and function testing of components with male thread, e.g. engines, cylinders, pressure vessels, hoses, fixtures, etc.

**Note:** For using the WEH® Connectors with pneumatic actuation and clamping jaws in an automated system please observe the technical explanation on page 71.

### TECHNICAL DATA

Characteristics	Basic version
Max. allowable operating pressure PS	Vacuum up to 350 bar
Pilot pressure	6 - 12 bar compressed air
Pilot pressure port P1	G1/8" female thread
Pilot pressure port P2	G1/4" female thread
Temperature range	+5 °C up to +80 °C
Leak rate	$1 \times 10^{-3}$ mbar x l/s
Actuation	H = manual actuation via lever V = pneumatic actuation via valve head P = pneumatic actuation for external manual, semi or fully automatic control systems
Material	Corrosion resistant stainless steel, anodized aluminum
Sealing material	Front seal of NBR

Other designs on request

#### Example of use:



# » WEH® Connector TW18

## ORDERING | WEH® TW18 Quick connector

approx. dimensions (mm)

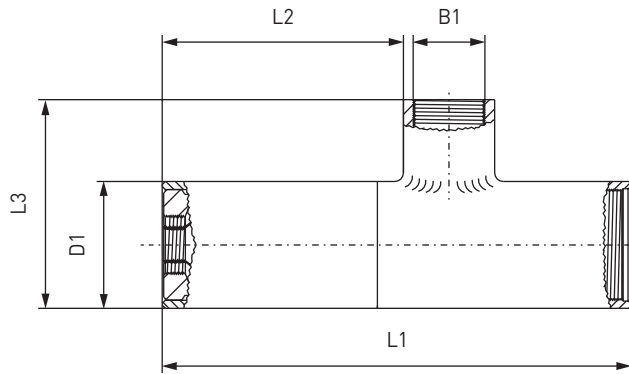

Body size 1 - 2

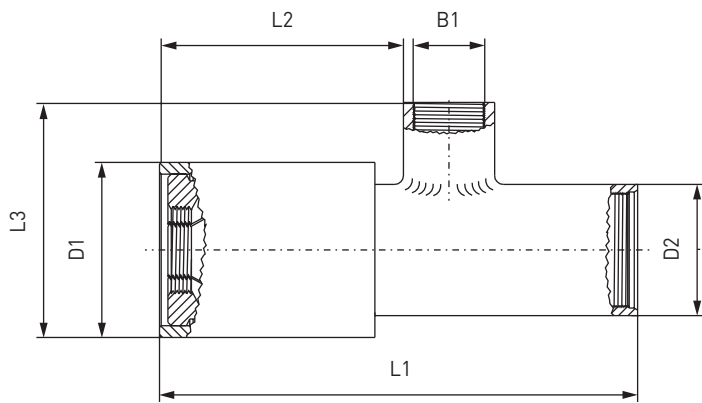

Body size 3

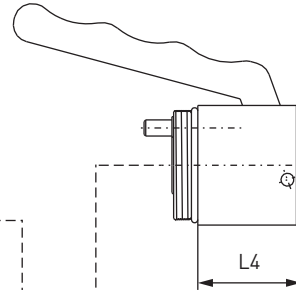

**H**  
Manually by depressing the lever.  
*Medium effort required.*

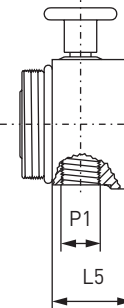

**V**  
Pneumatically by pressing the valve head.  
*Very little effort required.*

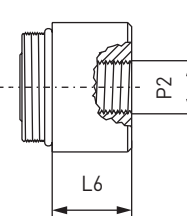

**P**  
Pneumatically for external manual, semi or fully automatic control systems

Body size	B1 (female thread)	D1	D2	L1	L2	L3	L4	L5	L6
1	G1/2"	32.0	-	134.0	65.0	57.5	25.0	18.0	18.0
2	G1/2"	39.0	-	142.0	71.0	64.5	32.0	18.0	18.0
3	G1/2"	52.0	39.0	142.0	70.5	64.5	32.0	18.0	18.0

## » WEH® Connector TW18

## Tube fitting to ISO 8434-1

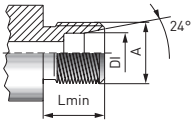

Part No.	Body size	Thread A (male thread)	Max. operating pressure**	DI max.	Series	Lmin*
TW18...-W8133-085	1	M8x1.0	100 bar	4.0	LL	8.0
TW18...-W8134-085	1	M10x1.0	100 bar	6.0	LL	8.0
TW18...-W8135-085	1	M12x1.0	100 bar	8.0	LL	9.0
TW18...-W8136-085	1	M12x1.5	250 bar	6.0	L	10.0
TW18...-W8137-085	1	M14x1.5	250 bar	8.0	L	10.0
TW18...-W8138-085	1	M16x1.5	250 bar	10.0	L	11.0
TW18...-W8139-085	2	M18x1.5	250 bar	12.0	L	11.0
TW18...-W8140-085	2	M22x1.5	250 bar	15.0	L	12.0
TW18...-W8141-085	3	M26x1.5	160 bar	18.0	L	12.0
TW18...-W8142-085	3	M30x2.0	160 bar	22.0	L	14.0

\* Lmin: minimum thread length

\*\* acc. to ISO 8434-1

## Threaded stem to DIN 7631 / DIN 7647 - Plane surface burr free

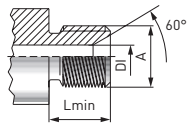

Part No.	Body size	Thread A (male thread)	DI max.	Lmin*
TW18...-W8151-085	1	M10x1.0	3.0	8.0
TW18...-W8152-085	1	M12x1.5	4.0	10.0
TW18...-W8153-085	1	M14x1.5	6.0	10.0
TW18...-W8154-085	1	M16x1.5	8.0	11.0
TW18...-W8155-085	2	M18x1.5	10.0	11.0
TW18...-W8214-085	2	M20x1.5	11.0	11.0
TW18...-W8156-085	2	M22x1.5	12.0	12.0
TW18...-W8157-085	3	M26x1.5	15.0	12.0
TW18...-W8158-085	3	M30x1.5	19.0	14.0

\* Lmin: minimum thread length

## » WEH<sup>®</sup> Connector TW18

Whitworth tube thread to ISO 7/1 or DIN EN ISO 228-1 - Plane surface smooth and burr free

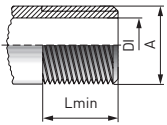

Part No.	Body size	Thread A (external thread)	DI max.	Lmin*
TW18...-W8127-085	1	G1/8"	5.0	12.0
TW18...-W8128-085	1	G1/4"	6.0	12.0
TW18...-W8129-085	1	G3/8"	9.0	12.0
TW18...-W8130-085	2	G1/2"	14.5	12.0
TW18...-W8131-085	3	G3/4"	18.0	12.0
TW18...-W8132-085	3	G1"	18.0	12.0

\* Lmin: minimum thread length

NPT thread (ANSI/ASME B1.20.1-1983) - acc. to SAE J476a, plane surface smooth and burr free

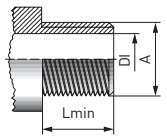

Part No.	Body size	Thread A (male thread)	DI max.	Lmin*
TW18...-W8208-085	1	NPT 1/8"	5.0	10.0
TW18...-W8207-085	1	NPT 1/4"	7.0	14.0
TW18...-W8209-085	1	NPT 3/8"	10.5	14.0
TW18...-W8210-085	2	NPT 1/2"	14.0	19.0
TW18...-W8211-085	3	NPT 3/4"	18.0	19.0
TW18...-W8212-085	3	NPT 1"	18.0	20.5

\* Lmin: minimum thread length

SAE J512 (45° cone), SAE J513

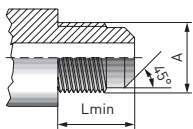

Part No.	Body size	Thread A (male thread)	Lmin*
TW18...-W8100-085	1	UNF 5/16"-24	11.0
TW18...-W8101-085	1	UNF 3/8"-24	11.5
TW18...-W8102-085	1	UNF 7/16"-20	13.0
TW18...-W8103-085	1	UNF 1/2"-20	14.5
TW18...-W8104-085	1	UNF 5/8"-18	16.0
TW18...-W8105-085	2	UNF 11/16"-16	17.5
TW18...-W8106-085	2	UNF 3/4"-16	19.0
TW18...-W8107-085	2	UNF 7/8"-14	22.5
TW18...-W8108-085	3	UN 1 1/16"-14	25.5

\* Lmin: minimum thread length

## » WEH® Connector TW18

SAE J514 JIC 37°

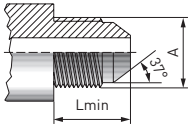

Part No.	Body size	Thread A (male thread)	Lmin*
TW18...-W8117-085	1	UNF 5/16"-24	11.5
TW18...-W8118-085	1	UNF 3/8"-24	12.5
TW18...-W8119-085	1	UNF 7/16"-20	14.0
TW18...-W8120-085	1	UNF 1/2"-20	14.0
TW18...-W8121-085	1	UNF 9/16"-18	14.5
TW18...-W8122-085	2	UNF 3/4"-16	17.0
TW18...-W8123-085	2	UNF 7/8"-14	19.5
TW18...-W8124-085	3	UN 1 1/16"-12	22.0

\* Lmin: minimum thread length

Other connection types on request.

Required information for ordering see page 9.

When ordering WEH® TW18 please indicate in addition to the details requested on page 7 the following information:

**1. Part no.**

Please insert within the part no. the letter corresponding to the desired type of actuation (H, V or P) in place of the position indicator (...)

*Example: TW18H-W8134-085*

**2. Pressure range**

Please add LP = low pressure version (up to 50 bar) or HP = high pressure version (up to 350 bar) at the end of the part number.

*Example: TW18H-W8134-085/HP*

## » WEH<sup>®</sup> Connector TW18

---

### ACCESSORIES

---

The following accessories are available for the WEH<sup>®</sup> TW18 Quick connector:

Screw plug for plug version (see page 15)

### SPECIAL SOLUTIONS

---

Example:



TW18H with extended clamping jaws  
for testing of ball valves



TW18Z with pneumatic actuation,  
central flow and  
lateral pressure support

## » WEH® Connector TW04

### DESCRIPTION



#### Features

- Pressure-tight connections by hand-tightening
- Simple seal replacement
- Ergonomic design
- High-grade materials

The WEH® TW04 Quick connector provides fast leak tight connections to components with male threads for testing, filling, plugging and venting.

Only hand-tighten the connector onto the thread until the o-ring seal contacts the test piece. The TW04 seals without wrenches, sealants or tape. NBR seals meet most industrial requirements.

The WEH® TW04 is available as an adapter with medium connection and as a plug.

#### Application

Quick connector for pressure and vacuum testing of components with male thread, e.g. fittings, fixtures, tubes, boilers, tanks, radiators, etc.

### TECHNICAL DATA

Characteristics	Basic version
Max. allowable operating pressure PS	Vacuum up to 50 bar
Temperature range	+5 °C up to +80 °C
Leak rate	$1 \times 10^{-3}$ mbar x l/s
Material	Corrosion resistant stainless steel
Sealing material	Front seal of polyurethane or NBR

Other designs on request

#### Example of use:



# » WEH<sup>®</sup> Connector TW04

## ORDERING | WEH<sup>®</sup> TW04 Quick connector

approx. dimensions (mm)

Connector with media inlet

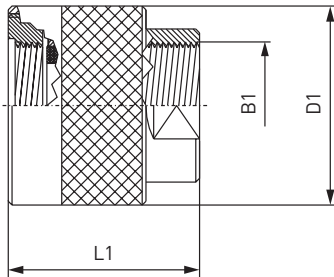

Connector with media inlet  
(SAE J512, J513, J514)

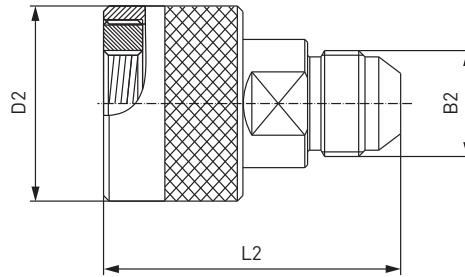

Plug

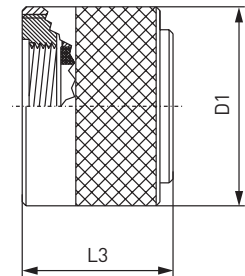

Body size	Inlet B1 (female thread)	Inlet B2 (male thread)	D1	D2	L1	L2 (SAE J512 / SAE J513)	L2 (SAE J514)	L3
1	G1/8"	-	22.0	-	35.5	-	-	25.5
2	G1/4"	UNF 7/16"-20	27.0	25.0	40.5	45.0	46.5	26.5
3	G3/8"	UNF 9/16"-18	32.0	30.0	38.0	48.0	48.0	28.0
4	G3/8"	UNF 3/4"-16	35.0	35.0	38.0	55.5	53.5	28.0
5	G1/2"	UNF 7/8"-14	37.0	38.0	51.0	63.0	59.5	33.0
6	G3/4"	UNF 1 1/16"-12	44.0	44.0	52.0	66.5	63.5	34.0
7	G1"	-	52.0	-	60.0	-	-	39.5

## » WEH® Connector TW04

Metric ISO thread to DIN 13 - Plane surface smooth and burr free

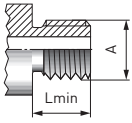

Part No.		Body size	Thread A (male thread)	Inlet B1 (female thread)	Max. operating pressure (PS)	Lmin*
Connector	Plug					
C1-12406	C1-12410	1	M10x1.0	G1/8"	50 bar	8.0
C1-12414	C1-12419	2	M12x1.5	G1/4"	50 bar	10.0
C1-12415	C1-12418	2	M14x1.5	G1/4"	50 bar	10.0
C1-12422	C1-12425	3	M16x1.5	G3/8"	50 bar	11.0
C1-12426	C1-12427	4	M18x1.5	G3/8"	50 bar	11.0
C1-188419	C1-12436	5	M20x1.5	G1/2"	50 bar	11.0
C1-12432	C1-12435	5	M22x1.5	G1/2"	50 bar	12.0
C1-12439	C1-12444	6	M24x1.5	G3/4"	50 bar	14.0
C1-173767	C1-188420	6	M26x1.5	G3/4"	50 bar	14.0

\* Lmin: minimum thread length

Whitworth tube thread to ISO 7/1 or DIN EN ISO 228-1 - Plane surface smooth and burr free

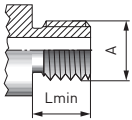

Part No.		Body size	Thread A (male thread)	Inlet B1 (female thread)	Max. operating pressure (PS)	Lmin*
Connector	Plug					
C1-12405	C1-187463	1	G1/8"	G1/8"	50 bar	12.0
C1-12412	C1-187466	2	G1/4"	G1/4"	50 bar	12.0
C1-12421	C1-12424	3	G3/8"	G3/8"	50 bar	12.0
C1-12429	C1-12434	5	G1/2"	G1/2"	50 bar	12.0
C1-12438	C1-12442	6	G3/4"	G3/4"	50 bar	12.0
C1-12446	C1-12447	7	G1"	G1"	50 bar	12.0

\* Lmin: minimum thread length

NPT thread (ANSI/ASME B1.20.1-1983) - acc. to SAE J476a, plane surface smooth and burr free

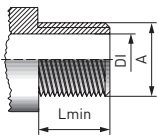

Part No.		Body size	Thread A (male thread)	Inlet B1 (female thread)	Max. operating pressure (PS)	DI max.	Lmin*
Connector	Plug						
C1-12404	C1-181156	1	NPT 1/8"	G1/8"	50 bar	5.0	10.0
C1-12411	C1-187467	2	NPT 1/4"	G1/4"	50 bar	7.0	14.0
C1-12420	C1-187464	3	NPT 3/8"	G3/8"	50 bar	10.5	14.0
C1-12428	C1-187468	5	NPT 1/2"	G1/2"	50 bar	14.0	19.0
C1-12437	C1-173837	6	NPT 3/4"	G3/4"	50 bar	18.0	19.0
C1-12445	C1-12448	7	NPT 1"	G1"	50 bar	24.0	20.5

\* Lmin: minimum thread length

## » WEH<sup>®</sup> Connector TW04

### SAE J512 (45° cone), SAE J513

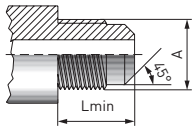

Part No.		Body size	Thread A (male thread)	Inlet B2 (female thread)	Max. operating pressure (PS)	Lmin*
Connector	Plug					
On request	On request	2	UNF 7/16"-20	UNF 7/16"-20	345 bar	13.0
On request	On request	4	UNF 3/4"-16	UNF 3/4"-16	276 bar	19.0
On request	On request	5	UNF 7/8"-14	UNF 7/8"-14	276 bar	22.5
On request	On request	6	UN 1 1/16"-14	UN 1 1/16"-14	172 bar	25.5

\* Lmin: minimum thread length

### SAE J514 JIC 37°

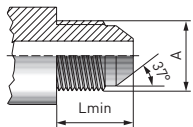

Part No.		Body size	Thread A (male thread)	Inlet B2 (female thread)	Max. operating pressure (PS)	Lmin*
Connector	Plug					
C1-35638	C1-119973	2	UNF 7/16"-20	UNF 7/16"-20	345 bar	14.0
C1-32445	C1-96356	3	UNF 9/16"-18	UNF 9/16"-18	345 bar	14.5
C1-32446	C1-17172	4	UNF 3/4"-16	UNF 3/4"-16	276 bar	17.0
C1-188422	C1-119975	5	UNF 7/8"-14	UNF 7/8"-14	276 bar	19.5
C1-32447	C1-119976	6	UN 1 1/16"-12	UN 1 1/16"-12	172 bar	22.0

\* Lmin: minimum thread length

Other connector sizes and versions on request.

Required information for ordering see page 9.

### ACCESSORIES

The following accessories are available for the WEH<sup>®</sup> TW04 Quick connector:

Screw plug for plug version (see page 15)

## » WEH® Connector TW800

### DESCRIPTION



#### Features

- Connection in seconds
- No hand tightening required
- WEH® Jaw locking mechanism
- High-grade materials
- Special versions possible

The WEH® TW800 Quick connector simplifies work procedures, shortens test times and improves productivity. Therefore the connector is ideal for pressure and function testing of components with a bead, rim, collar, flange, stub or male thread. In the automotive industry WEH® TW800 is also used for testing of fuel connections, connections for cold and hot water and other supply lines as well as air conditioning components.

By using high quality stainless steel the connectors meet the stringent requirements of industrial testing. The TW800 quick connector is designed for a pressure range up to max. 50 bar.

#### Application

Quick connector for pressure and function testing of components with bead, rim, collar, flange, stub or male thread, e.g. pressure vessels, compressors, heat exchangers, measuring devices, hoses, tubes, tanks, etc.

**Note:** For using the WEH® Connectors with pneumatic actuation and clamping jaws in an automated system please observe the technical explanation on page 71.

### TECHNICAL DATA

Characteristics	Basic version
Max. allowable operating pressure PS*	Vacuum up to 50 bar
Temperature range	+5 °C up to +80 °C
Leak rate	$1 \times 10^{-3}$ mbar x l/s
Material	Corrosion resistant stainless steel
Sealing material	Front seal of NBR

\* depending on application

Other designs on request

#### Example of use:



# » WEH® Connector TW800

## ORDERING | WEH® TW800 Quick connector

approx. dimensions (mm)

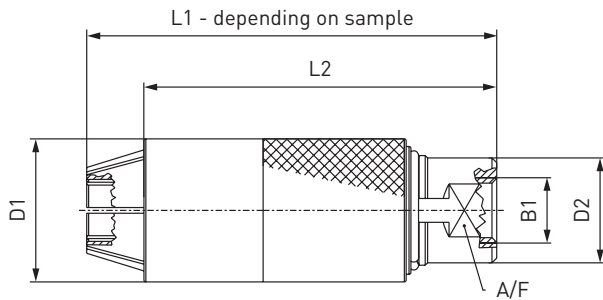

Body size	Inlet B1 (female thread)	D1	D2	L2	A/F
1	G1/8"	22.0	14.0	74.0	13
2	G1/8"	25.0	17.0	75.0	15
3	G1/4"	30.0	22.0	74.0	19
4	G3/8"	35.0	27.0	79.0	24
5	G1/2"	40.0	30.0	79.0	27
6	G3/4"	45.0	33.0	90.0	30
7	G3/4"	50.0	37.0	90.0	32
8	G3/4"	55.0	40.0	90.0	36
9	G1"	60.0	46.0	90.0	41
10	G1 1/4"	70.0	55.0	119.0	50

Other body sizes on request

## Beads for hose connections

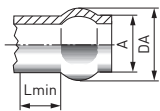

Part No.	Body size	Male tube Ø A	Max. operating pressure (PS)	DA + 0,5 / - 0	Lmin*
<b>TW800B-W8378-025</b>	1	7.0	10 bar	8.0	8.5
<b>TW800B-W8379-025</b>	1	7.5	10 bar	8.5	8.5
<b>TW800B-W8380-025</b>	1	8.0	10 bar	9.0	8.5
<b>TW800B-W8381-025</b>	2	10.0	10 bar	11.0	8.5
<b>TW800B-W8382-045</b>	3	12.0	10 bar	13.0	10.0
<b>TW800B-W8383-045</b>	3	12.5	10 bar	13.5	10.0
<b>TW800B-W8384-045</b>	3	15.0	10 bar	16.0	10.5
<b>TW800B-W8385-065</b>	4	16.0	10 bar	17.0	10.5
<b>TW800B-W8386-065</b>	4	18.0	10 bar	19.0	10.5
<b>TW800B-W8387-065</b>	4	20.0	10 bar	21.0	14.5
<b>TW800B-W8388-085</b>	5	22.0	10 bar	23.0	14.5
<b>TW800B-W8389-085</b>	5	25.0	10 bar	26.0	14.5
<b>TW800B-W8390-125</b>	6	28.0	10 bar	30.0	16.5
<b>TW800B-W8391-125</b>	6	30.0	10 bar	32.0	16.5
<b>TW800B-W8392-125</b>	7	32.0	10 bar	34.0	16.5
<b>TW800B-W8393-125</b>	7	35.0	10 bar	37.0	16.0
<b>TW800B-W8394-125</b>	8	38.0	10 bar	40.0	16.5
<b>TW800B-W8395-125</b>	8	40.0	10 bar	42.0	16.5
<b>TW800B-W8396-125</b>	8	42.0	10 bar	44.0	16.5

\* Lmin: min. required length after bead for clamping

## » WEH® Connector TW800

Whitworth tube thread to ISO 7/1 or DIN EN ISO 228-1 - Plane surface smooth and burr free

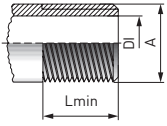

Part No.	Body size	Thread A (male thread)	Max. operating pressure (PS)	DI max.	Lmin*
TW800G-W8372-025	2	G1/8"	20 bar	5.0	12.0
TW800G-W8373-045	3	G1/4"	20 bar	8.5	12.0
TW800G-W8374-065	4	G3/8"	20 bar	10.5	12.0
TW800G-W8375-085	5	G1/2"	20 bar	14.5	12.0
TW800G-W8376-125	6	G3/4"	20 bar	20.0	12.0
TW800G-W8377-125	7	G1"	20 bar	25.0	12.0

\* Lmin: minimum thread length

Threaded stem to DIN 7631 / DIN 7647 - Plane surface burr free

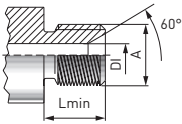

Part No.	Body size	Thread A** (male thread)	Max. operating pressure (PS)	DI max.	Lmin*
TW800G-W8400-025	2	M10x1.0	50 bar	3.0	8.0
TW800G-W8401-045	3	M12x1.5	50 bar	4.0	10.0
TW800G-W8402-045	3	M14x1.5	50 bar	6.0	10.0
TW800G-W8403-065	3	M16x1.5	50 bar	8.0	11.0
TW800G-W8404-065	4	M18x1.5	50 bar	10.0	11.0
TW800G-W8405-085	5	M22x1.5	50 bar	12.0	12.0
TW800G-W8406-125	6	M26x1.5	50 bar	15.0	12.0
TW800G-W8407-125	7	M30x1.5	50 bar	19.0	14.0
TW800G-W8408-125	8	M38x1.5	50 bar	25.0	14.0
TW800G-W8409-165	9	M45x1.5	50 bar	32.0	16.0

\* Lmin: minimum thread length

\*\* acc. to DIN 3853

SAE J514 JIC 37°

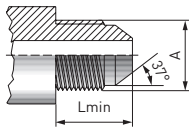

Part No.	Body size	Thread A (male thread)	Max. operating pressure (PS)	Lmin*
TW800G-W8318-025	1	UNF 5/16"-24	50 bar	11.5
TW800G-W8319-025	2	UNF 3/8"-24	50 bar	12.5
TW800G-W8320-025	2	UNF 7/16"-20	50 bar	14.0
TW800G-W8321-045	3	UNF 1/2"-20	50 bar	14.0
TW800G-W8322-045	3	UNF 9/16"-18	50 bar	14.5
TW800G-W8323-085	5	UNF 3/4"-16	50 bar	17.0
TW800G-W8324-085	5	UNF 7/8"-14	50 bar	19.5
TW800G-W8325-125	6	UN 1 1/16"-12	50 bar	22.0
TW800G-W8327-125	8	UN 1 5/16"-12	50 bar	23.5

\* Lmin: minimum thread length

# » WEH® Connector TW800

SAE J512 (45° cone), SAE J513

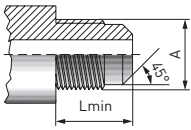

Part No.	Body size	Thread A (male thread)	Max. operating pressure (PS)	Lmin*
TW800G-W8300-025	1	UNF 5/16"-24	50 bar	11.0
TW800G-W8301-025	2	UNF 3/8"-24	50 bar	11.5
TW800G-W8302-025	2	UNF 7/16"-20	50 bar	13.0
TW800G-W8303-045	3	UNF 1/2"-20	50 bar	14.5
TW800G-W8311-045	3	UNF 9/16"-18	50 bar	**
TW800G-W8304-065	4	UNF 5/8"-18	50 bar	16.0
TW800G-W8305-065	4	UNF 11/16"-16	50 bar	17.5
TW800G-W8306-085	4	UNF 3/4"-16	50 bar	19.0
TW800G-W8307-085	5	UNF 7/8"-14	50 bar	22.5
TW800G-W8308-125	6	UN 1 1/16"-14	50 bar	25.5
TW800G-W8309-125	8	UN 1 1/4"-12	50 bar	28.5
TW800G-W8310-125	8	UN 1 3/8"-12	50 bar	**

\* Lmin: minimum thread length  
 \*\* on request

Other connector sizes and versions on request.

Required information for ordering see page 9.

## ACCESSORIES

The following accessories are available for the WEH® TW800:

Screw plug (see page 15)

## SPECIAL SOLUTIONS

Examples:



TW800 with 90° lateral port



TW800 with pneumatic actuated grip sleeve



TW800 twin connector

## » WEH® Connector TW850

### DESCRIPTION



#### Features

- Connection in seconds
- No hand tightening required
- WEH® jaw locking mechanism
- High-grade materials
- Special versions possible

The WEH® TW850 Quick connector simplifies work procedures, shortens test times and improves productivity. Therefore the connector is ideal for high pressure and function testing of components with a bead, rim, collar, flange, stub or male thread.

By using high quality stainless steel the connectors meet the stringent requirements of industrial testing. The TW850 quick connector is designed for a pressure range up to max. 630 bar.

#### Application

Quick connector for pressure and function testing of components with bead, rim, collar, flange, stub or male thread, e.g. pressure vessels, compressors, heat exchangers, measuring devices, hoses, tubes, tanks, etc.

**Note:** For using the WEH® Connectors with pneumatic actuation and clamping jaws in an automated system please observe the technical explanation on page 71.

### TECHNICAL DATA

Characteristics	Basic version
Max. allowable operating pressure PS*	Vacuum up to 630 bar
Temperature range	+5 °C up to +80 °C
Leak rate	$1 \times 10^{-3}$ mbar x l/s
Material	Corrosion resistant stainless steel
Sealing material	Front seal of NBR

\* depending on application

Other designs on request

#### Example of use:



# » WEH<sup>®</sup> Connector TW850

## ORDERING | WEH<sup>®</sup> TW850 Quick connector

approx. dimensions (mm)

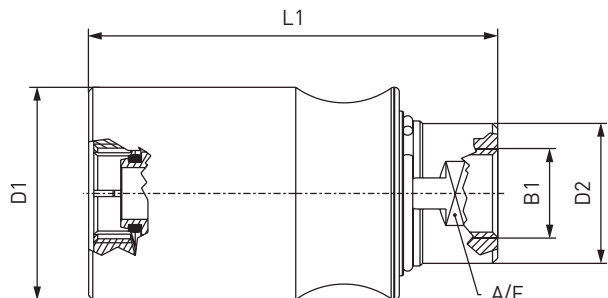

Body size	Inlet B1 (female thread)	D1	D2	L1	A/F
1	G1/8"	36.0	22.0	75.0	19
2	G3/8"	41.0	27.0	80.0	24
3	G3/8"	46.0	30.0	80.0	27
4	G1/2"	52.0	33.0	120.0	30

Other body sizes on request

## Tube fitting to ISO 8434-1

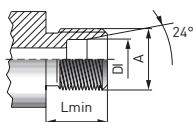

Part No.	Body size	Thread A (male thread)	Max. operating pressure**	DI max.	Series	Lmin*
<b>On request</b>	1	M10x1.0	100 bar	6.0	LL	8.0
<b>C1-109850</b>	1	M12x1.0	100 bar	8.0	LL	9.0
<b>C1-35809</b>	1	M12x1.5	250 bar	6.0	L	10.0
<b>C1-16988</b>	1	M14x1.5	250 bar	8.0	L	10.0
<b>C1-119138</b>	2	M16x1.5	250 bar	10.0	L	11.0
<b>C1-41109</b>	2	M18x1.5	250 bar	12.0	L	11.0
<b>C1-17601-X1</b>	3	M22x1.5	250 bar	15.0	L	12.0
<b>C1-17804</b>	4	M26x1.5	160 bar	18.0	L	12.0
<b>C1-18610</b>	4	M30x2.0	160 bar	22.0	L	14.0
<b>C1-11299</b>	1	M14x1.5	630 bar	6.0	S	12.0
<b>C1-84789</b>	2	M16x1.5	630 bar	8.0	S	12.0
<b>C1-43001</b>	2	M18x1.5	630 bar	10.0	S	12.0
<b>C1-11418</b>	2	M20x1.5	630 bar	12.0	S	12.0
<b>C1-11635-X1</b>	3	M24x1.5	400 bar	16.0	S	14.0
<b>C1-13281</b>	4	M30x2.0	400 bar	20.0	S	16.0

\* Lmin: minimum thread length

\*\* acc. to ISO 8434-1

Other connector sizes and versions on request.

Required information for ordering see page 9.

## ACCESSORIES

The following accessories are available for the WEH<sup>®</sup> TW850:

Screw plug (see page 15)

## » WEH® Connector TW130

### DESCRIPTION

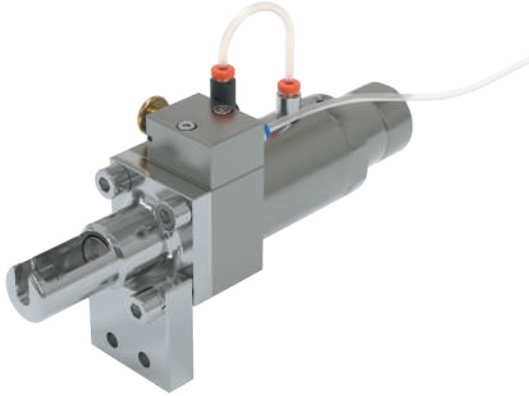

#### Features

- Connection in seconds
- No hand tightening required
- Testing of high quantities
- Suitable for automated testing
- Robust construction

The WEH® TW130 Quick connector has been developed specially for testing components with banjo tube connections, hose and tube connections with sleeve nuts and similar configurations.

The compact design and ease of operation enables cost-effective testing, even for high quantities. The connector is equipped with pneumatic valve actuation, a customer-tailored steel test piece holder and if required a retaining plate.

The WEH® TW130 is rated for a pressure range up to max. 350 bar. Automation is possible. Special versions, e.g. multi-connectors etc. are also available on request.

#### Application

Quick connector for pressure and function testing of components with banjo tube connections and hose / tube connections with sleeve nuts, e.g. for heat exchangers, high pressure hoses etc.

### TECHNICAL DATA

Characteristics	Basic version
Max. allowable operating pressure PS	350 bar
Pilot pressure	Max. 6 - 8 bar
Pilot pressure port P1	G1/8" female thread
Temperature range*	-10 °C up to +80 °C
Leak rate	$1 \times 10^{-3}$ mbar x l/s
Actuation	Pneumatic actuation via valve head. Automation possible
Material	Base unit: corrosion resistant stainless steel, anodized aluminum
Sealing material	Front seal of NBR

\* The values of the temperature ranges quoted apply for common hydraulic oils, for other media please contact us!

Other designs on request

#### Example of use:



# » WEH<sup>®</sup> Connector TW130

## ORDERING | WEH<sup>®</sup> TW130 Quick connector

approx. dimensions (mm)

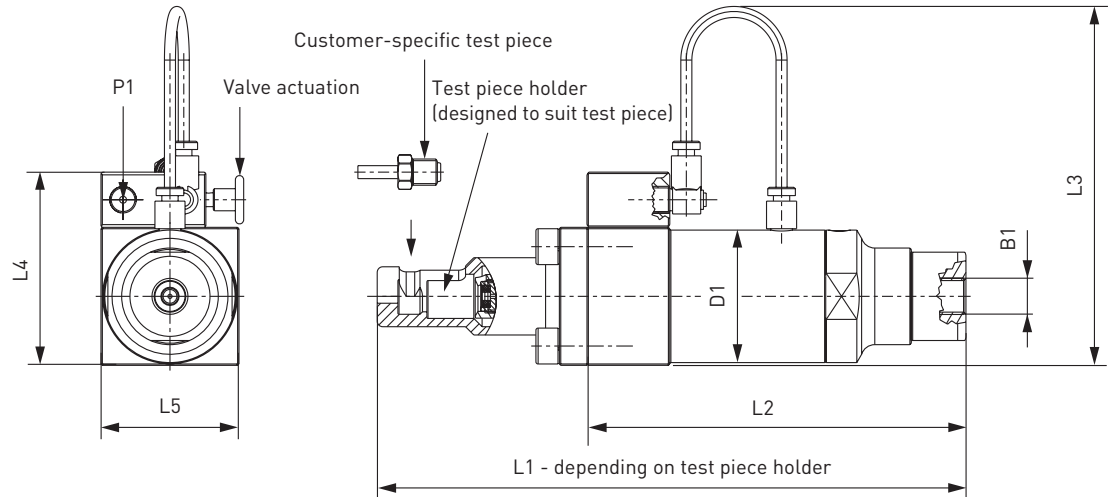

Part no.	Body size	Inlet B1 (female thread)	D1	L2	L3	L4	L5
On request	1	G1/4"	48.0	137.5	130.0	70.0	50.0
On request	2	G1/4"	62.0	137.5	140.0	84.0	64.0

Please send us your enquiry together with the corresponding test piece!  
Other connection sizes on request

Other connection types on request.

Required information for ordering see page 7.

## ACCESSORIES

The following accessories are available for the WEH<sup>®</sup> TW130 Quick connector:

### Fixturing parts

A retaining plate is also available for ease of clamping the TW130 to test bench. Please contact us!

## » WEH® Connector TW131

### DESCRIPTION



#### Features

- Connection in seconds
- No hand tightening required
- Testing of high quantities
- Robust construction
- Ergonomic design

The WEH® TW131 Quick connector is the manual version of the WEH® TW130 Quick connector. The connector has been developed specially for testing components with banjo tube connections, hose and tube connections with sleeve nuts and similar configurations.

A further important field of application is the testing of heat exchangers for the refrigeration and air conditioning industry, e.g. for solder connections.

The compact design and ease of operation enables cost-effective testing, even for high quantities. Simply pull back the grip sleeve and release it again to connect the test piece.

The test piece holder is individually adapted to the customer test piece.

The WEH® TW131 is rated for a pressure range up to max. 50 bar.

#### Application

Quick connector for pressure and function testing of components with banjo tube connection, hose and tube connection, e.g. for heat exchangers, etc.

### TECHNICAL DATA

Characteristics	Basic version
Operating pressure PS	Max. 50 bar*
Temperature range**	-10 °C up to +80 °C
Medium	Air, water, mineral oils, helium
Actuation	Manual actuation via grip sleeve
Material	Base unit: Corrosion resistant stainless steel, anodized aluminium
Sealing material	NBR
Registration	PED 2014/68/EC

\* Please note the product marking on the connector for the max. pressure to be applied

\*\* The values of the temperature ranges quoted apply for common hydraulic oils, for other media please contact us!

Other designs on request

#### Example of use:



# » WEH® Connector TW131

## ORDERING | WEH® TW131 Quick connector

approx. dimensions (mm)

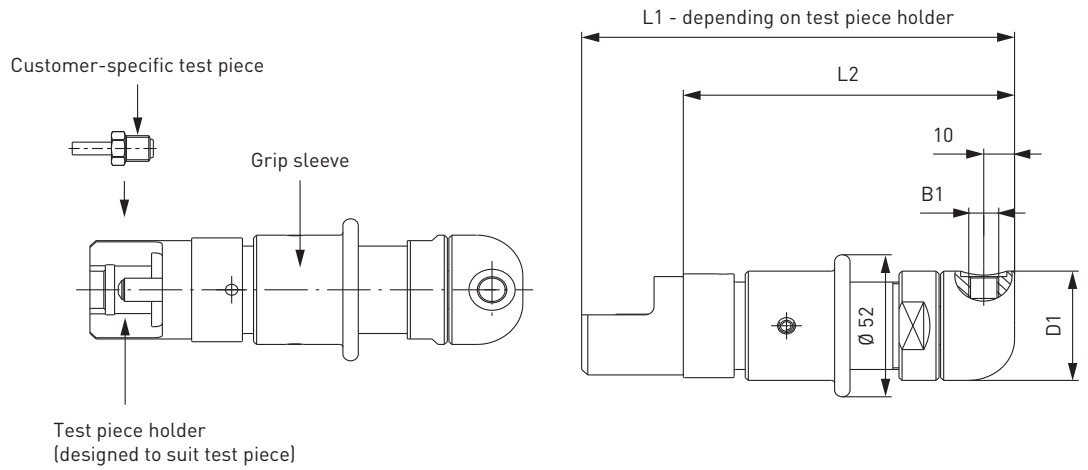

Part No.	Inlet B1 (female thread)	D1	L2
On request	G1/8"	40.0	108.0

Please send us your enquiry together with the corresponding test piece!

Other connector sizes and versions on request.

Required information for ordering see page 9.

## » WEH® Connector TW132

### DESCRIPTION



#### Features

- Connection in seconds
- No hand tightening required
- Testing of high quantities
- Suitable for automated testing
- Robust construction
- Ergonomic design

The WEH® TW132 Quick connector is the low pressure version of the WEH® TW130 Quick connector. The connector has been developed specially for testing components with banjo tube connections, hose and tube connections with sleeve nuts and similar configurations. Underwater applications are possible.

The compact design and ease of operation enables cost-effective testing, even for high quantities. The connector is actuated pneumatically. The test piece holder can be adapted to suit the customer test piece.

The WEH® TW132 is rated for a pressure range up to max. 50 bar. Automation is possible.

#### Application

Quick connector for pressure and function testing of components with banjo tube connections, hose / tube connections with sleeve nuts, e.g. for heat exchangers, high pressure hoses etc.

### TECHNICAL DATA

Characteristics	Basic version
Operating pressure PS	Max. 50 bar*
Pilot pressure	Max. 6 - 8 bar
Pilot pressure port P1	G1/8" internal thread
Temperature range**	-10 °C up to +80 °C
Medium	Air, water, mineral oils, helium
Actuation	Pneumatic actuation, automation is also possible
Material	Base unit: Corrosion resistant stainless steel, anodized aluminium
Sealing material	NBR
Registration	PED 2014/68/EC

\* Please note the product marking on the connector for the max. pressure to be applied

\*\* The values of the temperature ranges quoted apply for common hydraulic oils, for other media please contact us!

Other designs on request

#### Example of use:



# » WEH<sup>®</sup> Connector TW132

## ORDERING | WEH<sup>®</sup> TW132 Quick connector

approx. dimensions (mm)

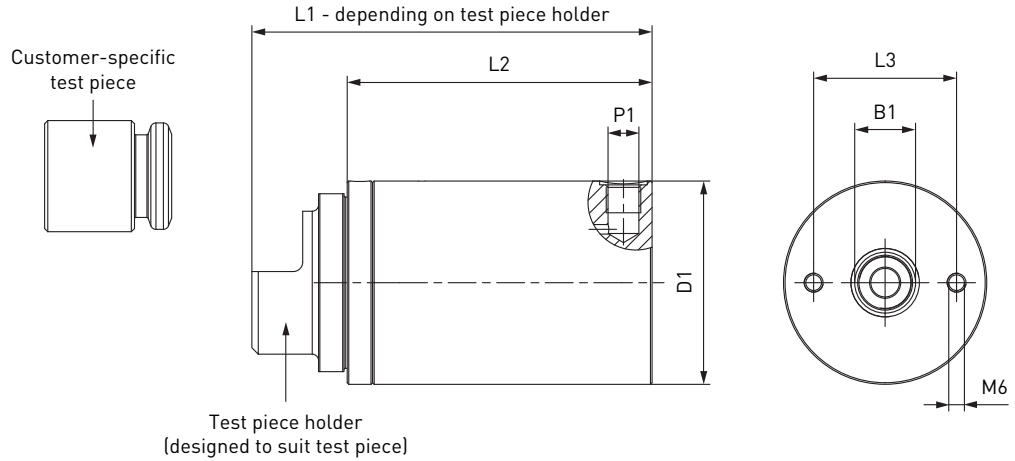

Part No.	Body size	Ø Sealing range	Inlet B1 (female thread)	D1	L2	L3
On request	1	5 - 15	G1/4"	50.0	96.0	36.0
On request	2	12 - 25	G1/2"	64.0	96.0	45.0

Please send us your enquiry together with the corresponding test piece!

Other connector sizes and versions on request.

Required information for ordering see page 9.

## ACCESSORIES

The following accessories are available for WEH<sup>®</sup> TW132:

### Fixturing parts

A retaining plate is also available for ease of clamping the TW132 to test bench. Please contact us!

### Hand slide valve

We also offer a hand slide valve for manual actuation of the pilot pressure at port 'P1' of the TW132 connector.



Part No.	Description	Connection P1 (female thread)	Connection P2 (male thread)
C1-48091	Hand slide valve	G1/8"	G1/8"

## » WEH® Connector TW141

### DESCRIPTION



#### Features

- Connection in seconds
- No hand tightening required
- For connection onto straight tubes, sealing on the external diameter
- No transverse forces generated on connection
- WEH® Jaw locking mechanism
- Ergonomic design
- High-grade materials

The WEH® TW141 Quick connector provides pressure-tight connections on straight tubes of copper, brass or aluminium and has earned a reputation for ease of operation.

The TW141 is a lever-actuated connector, which creates no transverse force that can distort the test piece or filling port when connecting and disconnecting. WEH® TW141 is fitted with an internal safety feature which prevents the connector from being removed until a pressure lower than 5 bar is attained.

The WEH® TW141 is equipped with a NBR front seal. Other sealing materials on request. It is the customer's responsibility to clarify the media compatibility.

#### Application

Quick connector for pressure and function testing of straight tubes (sealing on external tube diameter), as for example leak testing of heat exchangers, air conditioning components and tube assemblies. Filling of closed cooling circuits with refrigerants.

### TECHNICAL DATA

Characteristics	Basic version
Nominal bore (DN)	3 to 5 mm, acc. to design
Max. allowable operating pressure PS	Vacuum up to 100 bar
Temperature range	-10 °C up to +80 °C
Leak rate	$1 \times 10^{-3}$ mbar x l/s
Actuation	Manual actuation via hand lever
Max. allowable surface finish of test piece	Rz8 µm
Material	Clamping jaws: corrosion resistant stainless steel Housing: anodized aluminium
Sealing material	Front seal of NBR

Other designs on request

#### Example of use:



## » WEH<sup>®</sup> Connector TW141

### ORDERING | WEH<sup>®</sup> TW141 Quick connector – body size 1

approx. dimensions (mm)

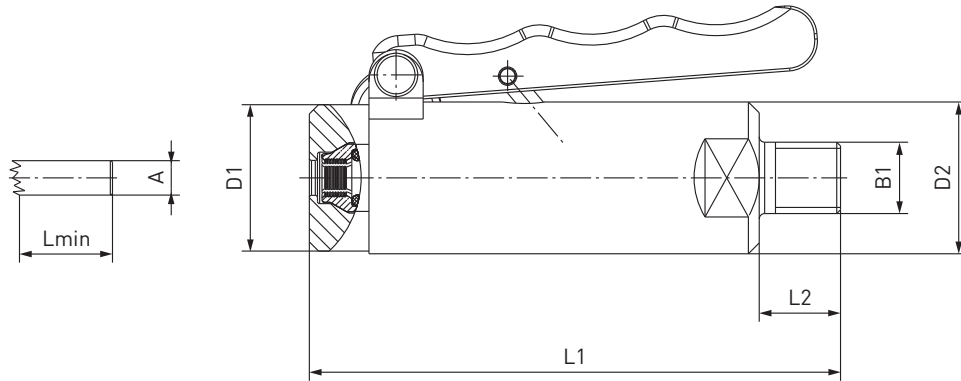

Part no.	Body size	Sealing range external tube $\varnothing$ A	Tolerance	B1 (male thread)	D1	D2	L1	L2	Lmin*
C1-17749	1	4,8 (3/16")	$\pm 0,2$	NPT 1/4"	27	28	100	15	19
C1-18575	1	5,0	$\pm 0,2$	NPT 1/4"	27	28	100	15	19
C1-14967-X2	1	6,0	$\pm 0,2$	NPT 1/4"	27	28	100	15	19
C1-17606	1	6,35 (1/4")	$\pm 0,2$	NPT 1/4"	27	28	100	15	19
C1-17750	1	7,9 (5/16")	$\pm 0,2$	NPT 1/4"	27	28	100	15	19
C1-14968	1	8,0	$\pm 0,2$	NPT 1/4"	27	28	100	15	19

\* Lmin: minimum insertion length of test piece  
Other connection sizes on request

## » WEH® Connector TW141

### ORDERING | WEH® TW141 Quick connector – body size 2 + 3

approx. dimensions (mm)

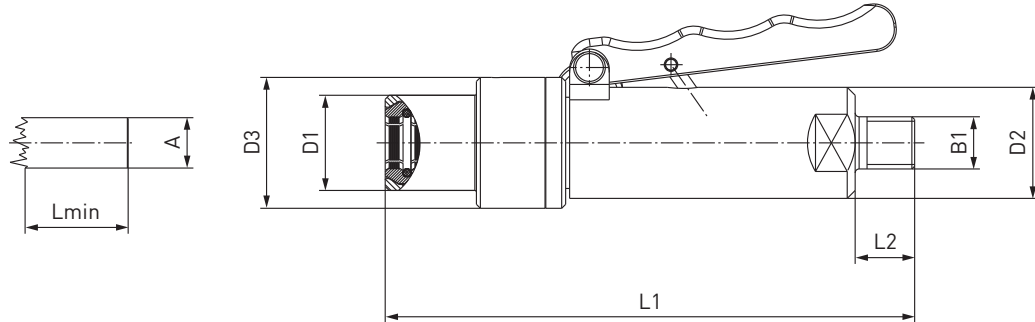

Part no.	Body size	Sealing range external tube Ø A	Tolerance	B1 (male thread)	D1	D2	D3	L1	L2	Lmin*
C1-17536	2	9.5 (3/8")	± 0.1	NPT 1/4"	21	28	33	134	15	19
C1-16773	2	10.0	± 0.1	NPT 1/4"	19	28	33	134	15	15
C1-16774	2	12.0	± 0.1	NPT 1/4"	21	28	33	134	15	15
C1-17751	2	12.7 (1/2")	± 0.1	NPT 1/4"	24	28	33	134	15	15
C1-16775-X1	2	15.0	± 0.1	NPT 1/4"	24	28	33	134	15	15
C1-17959	3	15.9 (5/8")	± 0.1	NPT 1/4"	32	28	49	134	15	15
C1-16776	3	16.0	± 0.1	NPT 1/4"	32	28	49	134	15	15
C1-16777	3	18.0	± 0.1	NPT 1/4"	34	28	49	134	15	15
C1-18006-X1	3	19.05 (3/4")	± 0.1	NPT 1/4"	34	28	49	134	15	15
C1-16778	3	22.0	± 0.1	NPT 1/4"	38	28	49	134	15	15
C1-17939-X1	3	22.2 (7/8")	± 0.1	NPT 1/4"	38	28	49	134	15	15

\* Lmin: minimum insertion length of test piece  
Other connection sizes on request

Other connection types on request.

Required information for ordering see page 9.

## » WEH® Connector TW141

### ACCESSORIES

The following accessories are available for the WEH® TW141 Quick connector:

#### Adaptor / Plug

For the TW141 different adaptors for other media inlets are available.  
If the WEH® Connector is to be used as a plug, the media inlet 'B1' can be sealed with a plug.



Part no.	Description	Connection
<b>E29-30810</b>	Adaptor	NPT 1/4" female thread - G1/4" female thread
<b>E201-30366</b>	Adaptor	NPT 1/4" female thread - G1/4" male thread
<b>E29-934P</b>	Adaptor	NPT 1/4" female thread - UNF 7/16" male thread
<b>E29-900P</b>	Plug	NPT 1/4" female thread

#### Anchor plate

WEH offers an anchor plate to create a safe, secure attachment for the TW141 and which can be used for all sealing ranges.

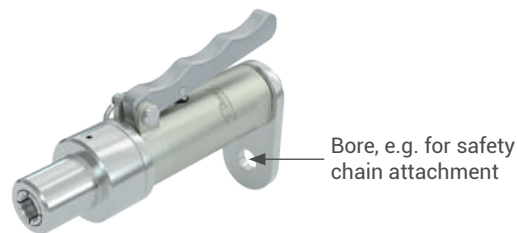

Part no.	Description
<b>E29-45285</b>	Anchor plate for TW141

### SPARE PARTS

Various parts are available as spares for the WEH® TW141 Quick connector.

Part no.	Description
<b>On request</b>	Front seal

When ordering the front seal, please indicate the part no. engraved on the connector.

## » WEH® Connector TW221

### DESCRIPTION



#### Features

- Connection in seconds
- No hand tightening required
- For connection into straight tubes and bores
- No seal adjustment required
- Wide range of tube tolerances
- High-grade materials

The WEH® TW221 Quick connector provides a pressure-tight connection to bores and straight tubes of copper, steel or aluminium within seconds. The connector is suitable for pressure and vacuum testing with oil free air or gaseous media. The manually operated connector is secured to the component by its connection seal. In this case it is important that during testing, the test piece and seals have to remain absolutely dry to ensure proper functioning and sealing.

The WEH® TW221 is equipped with a SBR front seal. It is the customer's responsibility to clarify the media compatibility.

#### Application

Quick connector for pressure and vacuum testing of straight tubes and bores (sealing the internal tube diameter), as for example pressure vessels, valves, transducers, compressors, condensers, tubing systems etc.

### TECHNICAL DATA

Characteristics	Basic version
Nominal bore (DN)	2 to 4 mm, acc. to design
Max. allowable operating pressure PS	3 bar
Temperature range	+5 °C up to +80 °C
Leak rate	$1 \times 10^{-3}$ mbar x l/s
Material	Body size 1+2: Anodized aluminium Body size 3: Stainless steel
Sealing material	Front seal of SBR

Other designs on request

#### Example of use:



# » WEH<sup>®</sup> Connector TW221

## ORDERING | WEH<sup>®</sup> TW221 Quick connector – body size 1 + 2

approx. dimensions (mm)

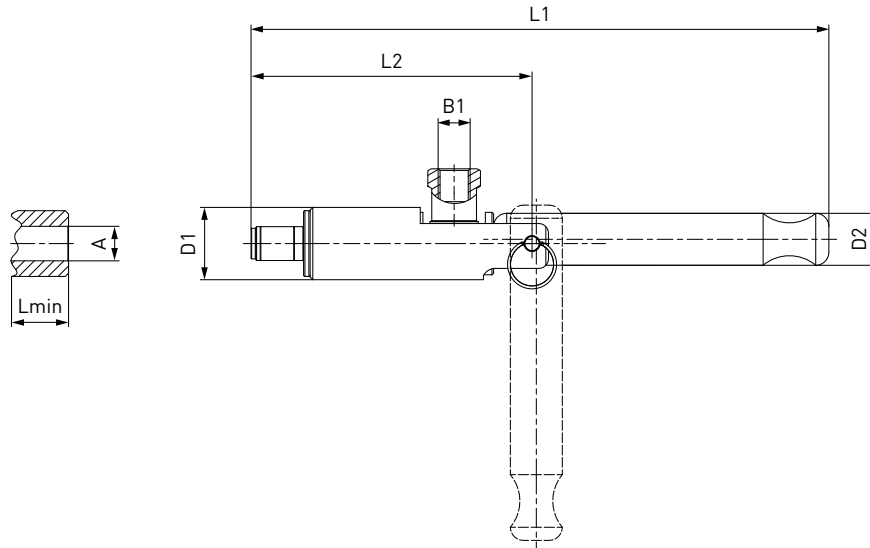

Part no.	Body size	Sealing range internal tube Ø A	B1 (female thread)	D1	D2	L1	L2	Lmin*	Replacement seal set** (consisting of 5 front seals + 5 o-rings)
C1-82309	1	9.5 - 10.4	G1/8"	22	16	176	86	16	B200B-89775
C1-82814	1	10.5 - 11.4	G1/8"	22	16	176	86	16	B200B-97248
C1-82305	1	11.5 - 12.4	G1/8"	22	16	176	86	16	B200B-90418
C1-82304	1	12.5 - 13.4	G1/8"	22	16	176	86	16	B200B-89774
C1-84246	2	13.5 - 14.4	G1/8"	22	16	186	96	29	B200B-91391
C1-84247	2	14.5 - 15.4	G1/8"	22	16	186	96	29	B200B-132009
C1-84248	2	15.5 - 16.4	G1/8"	22	16	186	96	29	B200B-90420
C1-84249	2	16.5 - 17.4	G1/8"	22	16	186	96	29	B200B-98586
C1-84251	2	17.5 - 18.4	G1/8"	22	16	186	96	29	B200B-95777
C1-82300	2	18.5 - 19.4	G1/8"	22	16	186	96	29	B200B-90416
C1-84252	2	19.5 - 20.4	G1/8"	22	16	186	96	29	B200B-90442
C1-82307	2	20.5 - 21.4	G1/8"	22	16	186	96	29	B200B-135789
C1-82308	2	21.5 - 22.4	G1/8"	22	16	186	96	29	B200B-95700
C1-84253	2	22.5 - 23.4	G1/8"	22	16	186	96	29	B200B-95894
On request	2	23.5 - 24.4	G1/8"	22	16	186	96	29	B200B-84806

\* Lmin: minimum insertion length of test piece

\*\* Replacement seal sets for body size 2 with a sealing range > 13.5 mm always include 10 front seals

Note: required roundness of internal tube diameter max. 0.25 mm

Other connection sizes on request

## » WEH® Connector TW221

### ORDERING | WEH® TW221 Quick connector – body size 3

approx. dimensions (mm)

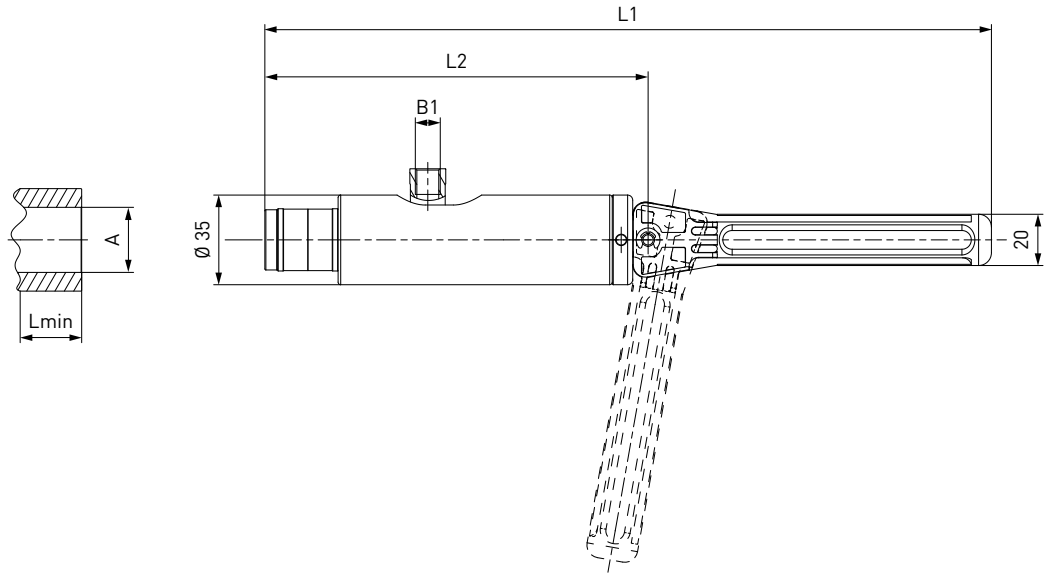

Part No.	Body size	Sealing range internal tube Ø A	Inlet B1 (female thread)	L1	L2	Lmin*	Replacement seal set (consisting of 10 front seals + 5 o-rings)
<b>C1-86878</b>	3	24.5 - 25.4	G1/8"	285	150	30	<b>B200B-89777</b>
<b>C1-84141</b>	3	25.5 - 26.4	G1/8"	285	150	30	<b>B200B-91135</b>
<b>C1-88744</b>	3	26.5 - 27.4	G1/8"	285	150	30	<b>B200B-97374</b>
<b>C1-86190</b>	3	27.5 - 28.4	G1/8"	285	150	30	<b>B200B-89778</b>
<b>C1-87141</b>	3	28.5 - 29.4	G1/8"	285	150	30	<b>B200B-135788</b>
<b>C1-86191</b>	3	29.5 - 30.4	G1/8"	285	150	30	<b>B200B-96452</b>

\* Lmin: minimum insertion length of test piece

Note: required roundness of internal tube diameter max. 0.25 mm

Other connector sizes and versions on request.

Required information for ordering see page 9.

## » WEH® Connector TW221

---

### ACCESSORIES

---

The following accessories are available for the WEH® TW221 Quick connector:

#### Screw plug for plug version

---

If the WEH® Connector is to be used as a plug, the media inlet 'B1' can be sealed with a screw plug of brass with a PVC sealing ring for low pressure range. It is recommended that the media compatibility of the seal be tested by the customer!



Part no.	Description	Connection (male thread)	Pressure range
E69-9200	Screw plug (low pressure)	G1/8"	0 - 50 bar

## » WEH® Connector TW230

### DESCRIPTION

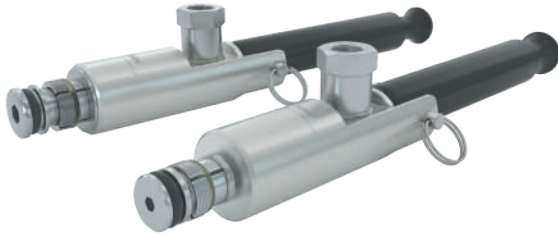

#### Features

- Connection in seconds
- No hand tightening required
- For connection into straight tubes and bores
- WEH® Jaw locking mechanism
- No seal adjustment required
- Wide range of tube tolerances up to  $\pm 0.25$  mm
- High-grade materials

With the WEH® TW230 Quick connector straight tubes of copper, steel or aluminium can be easily tested for leak tightness in just seconds. The radial sealing system reliably seals inside tube and bore diameters from 9.5 mm to 22.2 mm and bridges tube tolerances of up to  $\pm 0.25$  mm.

Connection to the straight tube is established by manual actuation of the clamping lever. Thanks to the WEH® Jaw locking mechanism the connector is securely located in the straight tube and the wear of the test piece is minimized as surface pressure is very low.

The TW230 is also suited for underwater, pressure decay and helium tests.

The WEH® TW230 is equipped with a NBR front seal. Other sealing materials on request. It is the customer's responsibility to clarify the media compatibility.

#### Application

Quick connector for pressure and vacuum testing of straight tubes and bores (sealing the internal tube diameter), as for example heat exchangers, pressure vessels, valves, transducers, compressors, condensers, evaporation coils, component and tubing systems, air conditioners, heating systems etc.

### TECHNICAL DATA

Characteristics	Basic version
Nominal bore (DN)	2 to 5 mm, acc. to design
Max. allowable operating pressure PS	Vacuum up to 70 bar
Temperature range	+5 °C up to +80 °C
Leak rate	$1 \times 10^{-3}$ mbar x l/s
Max. allowable surface finish of test piece	Rz8 $\mu$ m
Max. allowable material hardness of test piece	28 HRC
Material	Clamping jaws: corrosion-resistant stainless steel, hardened Housing: anodized aluminium
Sealing material	Front seal of NBR

Other designs on request

#### Example of use:

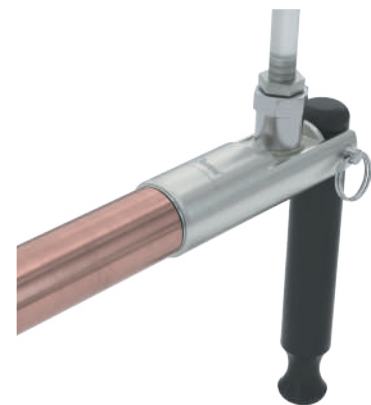

# » WEH<sup>®</sup> Connector TW230

## ORDERING | WEH<sup>®</sup> TW230 Quick connector – body size 1

approx. dimensions (mm)

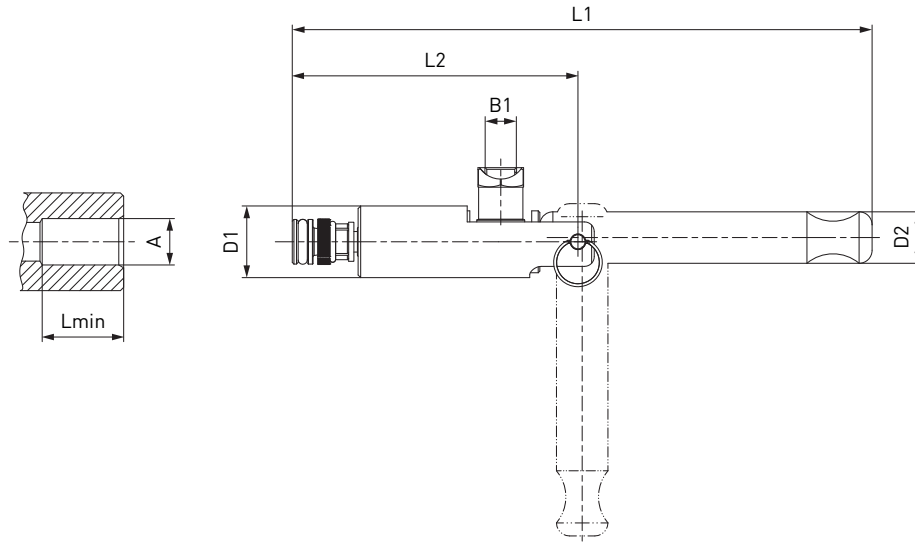

Part no.	Body size	Sealing range internal tube $\varnothing$ $A \pm 0.25$	B1 (female thread)	D1	D2	L1	L2	Lmin*	Replacement seal set (consisting of 5 front seals + 1 retaining ring for the clamping jaws)
<b>C1-128668</b>	1	9.5 (3/8")	G1/8"	22	16	178	87.5	13.5	<b>B200B-129358</b>
<b>C1-128734</b>	1	10.0	G1/8"	22	16	178	87.5	13.5	<b>B200B-129364</b>
<b>C1-128432</b>	1	10.5	G1/8"	22	16	178	87.5	13.5	<b>B200B-129369</b>
<b>C1-128742</b>	1	11.0 (7/16")	G1/8"	22	16	178	87.5	13.5	<b>B200B-129373</b>
<b>C1-128745</b>	1	11.5	G1/8"	22	16	178	87.5	13.5	<b>B200B-129376</b>
<b>C1-128750</b>	1	12.0	G1/8"	22	16	178	87.5	13.5	<b>B200B-129381</b>
<b>C1-128754</b>	1	12.5	G1/8"	22	16	178	87.5	13.5	<b>B200B-129385</b>
<b>C1-128756</b>	1	12.7 (1/2")	G1/8"	22	16	178	87.5	13.5	<b>B200B-129387</b>
<b>C1-128758</b>	1	13.0	G1/8"	22	16	178	87.5	13.5	<b>B200B-129389</b>
<b>C1-128763</b>	1	13.5	G1/8"	22	16	178	87.5	13.5	<b>B200B-129394</b>
<b>C1-128767</b>	1	14.0	G1/8"	22	16	178	87.5	13.5	<b>B200B-129398</b>

\* Lmin: minimum insertion length of test piece

When ordering, please state if testing reinforced fibre glass or plastic test pieces.

Other connection sizes on request

## » WEH® Connector TW230

### ORDERING | WEH® TW230 Quick connector – body size 2

approx. dimensions (mm)

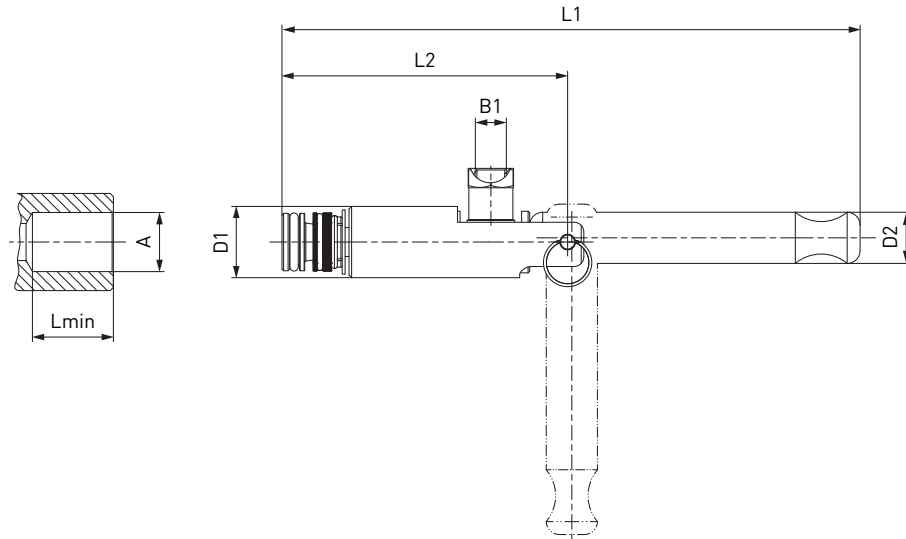

Part no.	Body size	Sealing range internal tube Ø A ± 0.25	B1 (female thread)	D1	D2	L1	L2	Lmin*	Replacement seal set** (consisting of 5 front seals + 2 retaining rings for the clamping jaws)
C1-128770	2	14.5	G1/8"	22	16	178.5	88	16.0	B200B-129401
C1-128774	2	15.0	G1/8"	22	16	178.5	88	16.0	B200B-129405
C1-128778	2	15.5	G1/8"	22	16	178.5	88	16.0	B200B-129409
C1-128782	2	15.9 (5/8")	G1/8"	22	16	178.5	88	16.0	B200B-129414
C1-128783	2	16.0	G1/8"	22	16	178.5	88	16.0	B200B-129415
C1-128789	2	16.5	G1/8"	22	16	178.5	88	16.0	B200B-129421
C1-128792	2	17.0	G1/8"	22	16	178.5	88	16.0	B200B-129424
C1-128796	2	17.5	G1/8"	22	16	178.5	88	16.0	B200B-129434
C1-128798	2	18.0	G1/8"	22	16	178.5	88	16.0	B200B-129436
C1-128802	2	18.5	G1/8"	22	16	178.5	88	16.0	B200B-129441
C1-128805	2	19.05 (3/4")	G1/8"	22	16	178.5	88	16.0	B200B-129445
C1-128809	2	19.5	G1/8"	22	16	178.5	88	16.0	B200B-129449
C1-128810	2	20.0	G1/8"	22	16	178.5	88	16.0	B200B-129450
C1-128813	2	20.5	G1/8"	22	16	178.5	88	16.0	B200B-129453
C1-128816	2	21.0	G1/8"	22	16	178.5	88	16.0	B200B-129456
C1-128818	2	21.5	G1/8"	22	16	178.5	88	16.0	B200B-129458
C1-128820	2	22.0	G1/8"	22	16	178.5	88	16.0	B200B-129460
C1-128821	2	22.2 (7/8")	G1/8"	22	16	178.5	88	16.0	B200B-129461

\* Lmin: minimum insertion length of test piece

\*\* Replacement seal sets for body size 2 with a sealing range < 15.9 mm only contain 1 retaining ring for the clamping jaws  
When ordering, please state if testing reinforced fibre glass or plastic test pieces.  
Other connection sizes on request

Other connection types on request.

Required information for ordering see page 9.

## » WEH® Connector TW230

---

### ACCESSORIES

---

The following accessories are available for the WEH® TW230 Quick connector:

#### Screw plug for plug version

---

If the WEH® Connector is to be used as a plug, the media inlet 'B1' can be sealed with a screw plug of stainless steel with an o-ring of NBR 70° Shore for high pressure range. It is recommended that the media compatibility of the seal be tested by the customer!



Part no.	Description	Connection (male thread)	Pressure range
<b>W9329</b>	Screw plug (high pressure)	G1/8"	0 - 350 bar

## » WEH® Connector TW241

### DESCRIPTION



#### Merkmale

- For connection onto straight tubes, sealing on the external diameter
- Self-retaining up to max. 70 bar
- Connection in seconds
- No hand tightening required
- WEH® Jaw locking mechanism
- No seal adjustment required
- Wide range of tube tolerances up to  $\pm 0.25$  mm
- High-grade materials

The WEH® TW241 Quick connector enables quick and easy leak testing of straight tubes of copper, steel or aluminium with an outer diameter of 6.0 to 44.0 mm. The connector is also suitable for underwater, pressure decay and helium testing.

The WEH® TW241 seals external diameters of straight tubes within seconds and bridges large tube tolerances of up to  $\pm 0.25$  mm with no operational adjustment of seals.

The WEH® Jaw locking mechanism provides maximum grip with minimum distortion of the test piece. There is no need for additional fixing. Operation is amazingly easy. Plug the WEH® Connector onto the tube, actuate the clamping lever and the pressure tight connection is made. An internal pressure support provides additional safety for the operator ensuring that disconnection is not possible until pressure has decreased to a safe value below 5 bar.

The WEH® TW241 is equipped with a chloroprene front seal. Other sealing materials on request. It is the customer's responsibility to clarify the media compatibility.

#### Application

Quick connector for pressure and vacuum testing of straight tubes (sealing on external tube diameter) as for example heat exchangers, pressure vessels, valves, transducers, compressors, condensers, evaporation coils, tubing systems, air conditioners, heating systems etc.

### TECHNICAL DATA

Characteristics	Basic version
Nominal bore (DN)	4 to 19 mm, acc. to design
Max. allowable operating pressure PS	Vacuum up to 70 bar
Temperature range	+5 °C up to +80 °C
Leak rate	$1 \times 10^{-3}$ mbar x l/s
Max. allowable surface finish of test piece	Rz8 $\mu$ m
Max. allowable material hardness of test piece	28 HRC
Material	Clamping jaws: corrosion-resistant stainless steel, hardened Housing: anodized aluminium
Sealing material	Front seal of chloroprene

Other designs on request

#### Example of use:



# » WEH<sup>®</sup> Connector TW241

## ORDERING | WEH<sup>®</sup> TW241 Quick connector – body size 1

approx. dimensions (mm)

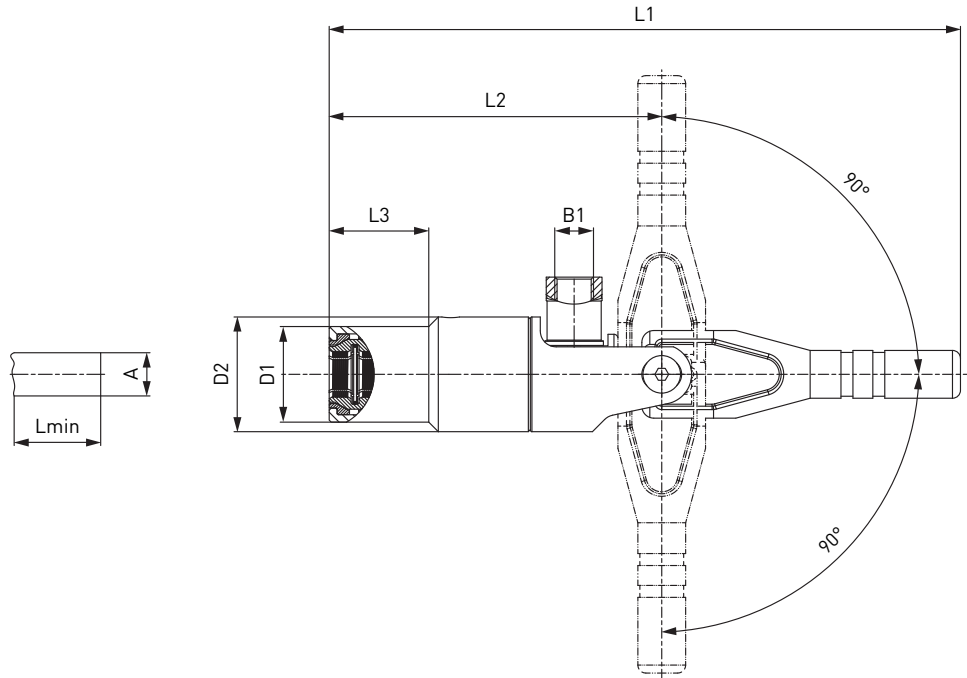

Part no.	Body size	Sealing range external tube Ø A ± 0.25	B1 (female thread)	D1	D2	L1	L2	L3	Lmin*	Replacement seal set (consisting of 5 front seals)
<b>C1-130646</b>	1	6.0	G1/8"	24	28.8	158.5	83.5	25	26.5	<b>B202B-130704</b>
<b>C1-130647</b>	1	6.35 (1/4")	G1/8"	24	28.8	158.5	83.5	25	26.5	<b>B202B-130705</b>
<b>C1-130654</b>	1	7.9 (5/16")	G1/8"	24	28.8	158.5	83.5	25	26.5	<b>B202B-130713</b>
<b>C1-130655</b>	1	8.0	G1/8"	24	28.8	158.5	83.5	25	26.5	<b>B202B-130714</b>
<b>C1-130661</b>	1	9.5 (3/8")	G1/8"	24	28.8	158.5	83.5	25	26.5	<b>B202B-130720</b>
<b>C1-130663</b>	1	10.0	G1/8"	24	28.8	158.5	83.5	25	26.5	<b>B202B-130722</b>

\* Lmin: minimum insertion length of test piece

When ordering, please state if testing reinforced fibre glass or plastic test pieces.  
Other connection sizes on request

## » WEH® Connector TW241

### ORDERING | WEH® TW241 Quick connector – body size 2

approx. dimensions (mm)

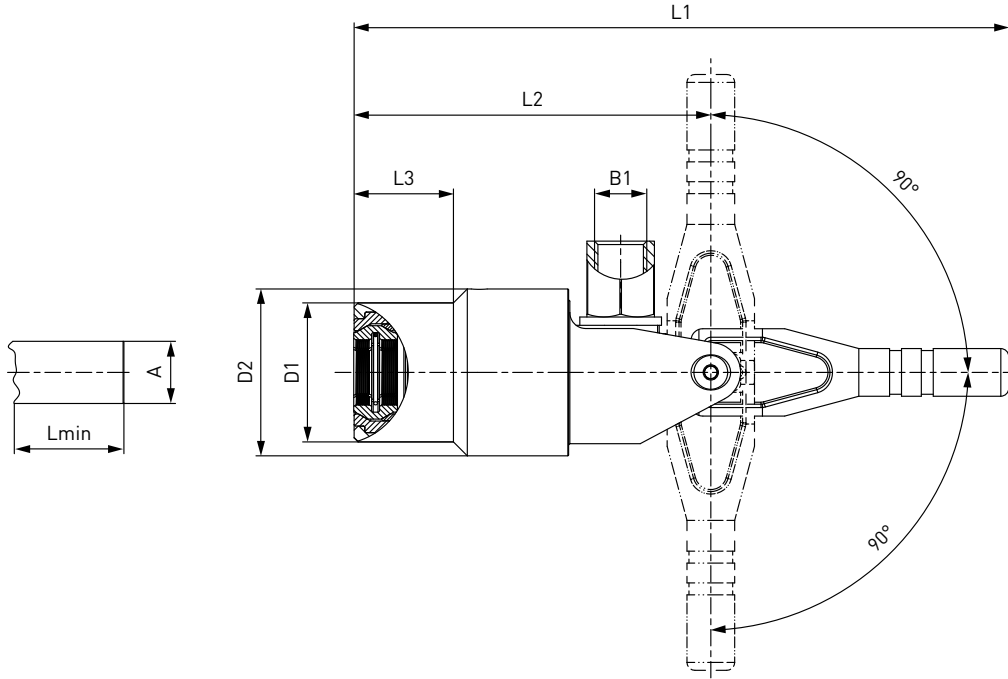

Part no.	Body size	Sealing range external tube Ø A ± 0.25	B1 (female thread)	D1	D2	L1	L2	L3	Lmin*	Replacement seal set (consisting of 5 front seals)
<b>C1-130672</b>	2	12.0	G1/4"	35	42	165	90	25	26.5	<b>B202B-130732</b>
<b>C1-130674</b>	2	12.7 (1/2")	G1/4"	35	42	165	90	25	26.5	<b>B202B-130734</b>
<b>C1-130685</b>	2	15.9 (5/8")	G1/4"	35	42	165	90	25	26.5	<b>B202B-130745</b>
<b>C1-130686</b>	2	16.0	G1/4"	35	42	165	90	25	26.5	<b>B202B-130746</b>

\* Lmin: minimum insertion length of test piece

When ordering, please state if testing reinforced fibre glass or plastic test pieces.

Other connection sizes on request

# » WEH<sup>®</sup> Connector TW241

## ORDERING | WEH<sup>®</sup> TW241 Quick connector – body size 3

approx. dimensions (mm)

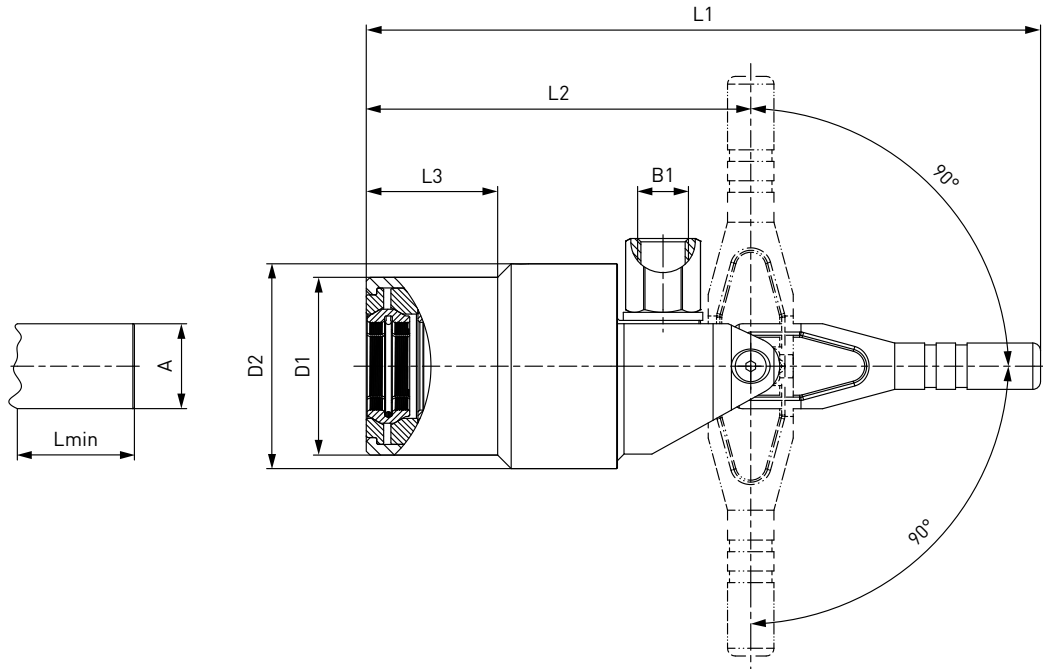

Part no.	Body size	Sealing range external tube Ø A ± 0.25	B1 (female thread)	D1	D2	L1	L2	L3	Lmin*	Replacement seal set (consisting of 5 front seals)
C1-130691	3	19.05 (3/4")	G1/4"	46	53	175	100	34	26	B202B-130752
C1-130694	3	22.0	G1/4"	46	53	175	100	34	26	B202B-130755
C1-130695	3	22.2 (7/8")	G1/4"	46	53	175	100	34	26	B202B-130756

\* Lmin: minimum insertion length of test piece

When ordering, please state if testing reinforced fibre glass or plastic test pieces.

Other connection sizes on request

## » WEH® Connector TW241

### ORDERING | WEH® TW241 Quick connector – body size 4 - 7

approx. dimensions (mm)

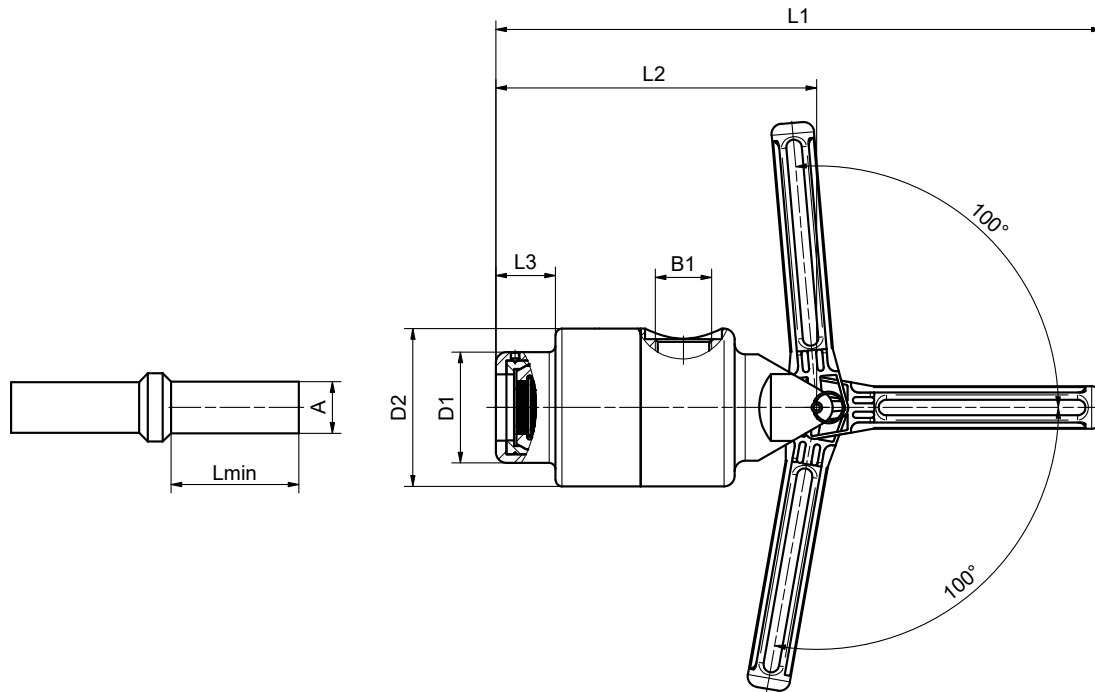

Part No.	Body size	Sealing range external tube Ø A ± 0.2	Inlet B1 (female thread)	D1	D2	L1	L2	L3	Lmin*	Replacement seal set (consisting of 5 front seals)
C1-108200	4	24,0	G3/4"	52	74	285	151	28	39	B202B-145689
C1-145909	4	25,0	G3/4"	52	74	285	151	28	39	B202B-145934
C1-108201	4	25,4 (1")	G3/4"	52	74	285	151	28	39	B202B-145690
C1-108202	4	26,0	G3/4"	52	74	285	151	28	39	B202B-145691
C1-108203	4	28,0	G3/4"	52	74	285	151	28	39	B202B-145692
C1-108204	4	28,5 (1 1/8")	G3/4"	52	74	285	151	28	39	B202B-145693
C1-108205	5	30,0	G3/4"	57	79	285	151	28	39	B202B-145694
C1-108209	5	34,9 (1 3/8")	G3/4"	57	79	285	151	28	39	B202B-145698
C1-145910	5	35,0	G3/4"	57	79	285	151	28	39	B202B-145935
C1-108211	6	38,0	G3/4"	62	89	285	151	29	39	B202B-145700
C1-108214	7	42,0	G3/4"	67	89	285	151	29	39	B202B-145703
C1-181585	7	44,0	G3/4"	67	89	285	151	29	39	B202B-145704

\* Lmin: erforderliche Einführtiefe des Prüflings

Werden Prüflinge aus faserverstärkten Kunststoffen eingesetzt, geben Sie dies bitte bei Ihrer Bestellung an.

Other connector sizes and versions on request.

Required information for ordering see page 9.

## » WEH® Connector TW241

### ACCESSORIES

The following accessories are available for the WEH® TW241 Quick connector:

#### Screw plug for plug version

If the WEH® Connector is to be used as a plug, the media inlet 'B1' can be sealed with a screw plug of stainless steel with an o-ring of NBR 70° Shore for high pressure range. It is recommended that the media compatibility of the seal be tested by the customer!



Part no.	Description	Connection (male thread)	Pressure range
<b>W9329</b>	Screw plug (high pressure)	G1/8"	0 - 350 bar
<b>W9330</b>	Screw plug (high pressure)	G1/4"	0 - 350 bar
<b>W9399</b>	Screw plug (high pressure)	G3/4"	0 - 350 bar

#### Lever extension

As standard the TW241 quick connector has a short lever for easy connection to components at difficult-to-access ports. A lever extension for applications with no restricted space is optionally available enhancing comfort in operation.



Part no.	Description
<b>E67-137059</b>	Lever extension for TW241

## » WEH® Connector TW01

### DESCRIPTION



#### Features

- Connection in seconds
- No hand tightening required
- Sealing irregular or rough surfaces
- Stroke limitation
- Simple seal replacement
- Ergonomic design
- High-grade materials

The WEH® TW01 Quick connector reliably and quickly seals inside bores, irregular or rough holes and female threaded components. Fitted with elastomer seals ideal for sealing out of round and rough surfaces and clearing large tolerances on the test piece. The connector only clamps itself firmly over the sealing rubber of the test piece, but does not have any retaining function. Therefore a fixture must be used.

As a standard WEH® TW01 is equipped with a stroke limitation. Because of the pneumatic actuation, the connector is particularly well suited for automation of test procedures.

A number of accessories are available for manual actuation of the pilot pressure, e.g. hand slide valve or pneumatic coupling with control/venting fitting (see accessories).

For WEH® TW01 Connectors standard shaft extensions of 1" (25.4 mm) or 2" (50.8 mm) are available to seal surfaces which are inaccessible to standard TW01 connectors.

Special versions, e.g. twin connectors for sealing ports in close proximity to each other are available on request.

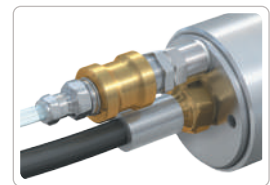

TW01 with hand slide valve

#### Application

Quick connector for pressure and vacuum testing of straight tubes and bores (sealing the internal tube diameter).

Leak testing: pressure decay, underwater / helium tests.

Other applications: filling, pressure and function tests, flushing, etc.

Components: vessels, plastic vessels, medical components, valves, pumps, filter, pressure vessels, tube connections, etc.

### TECHNICAL DATA

Characteristics	Basic version
Max. allowable operating pressure PS	Vacuum up to 9 bar
Pilot pressure	Body size 01: 6 - 9 bar compressed air Body size 1 - 8: 6 - 12 bar compressed air
Temperature range	+5 °C up to +80 °C
Leak rate	$1 \times 10^{-3}$ mbar x l/s
Material	Housing, piston and spacer: aluminum
Sealing material	Main seal of chloroprene / o-rings of NBR Urethane seals for high-wear applications are optional.

Other designs on request

#### Example of use:

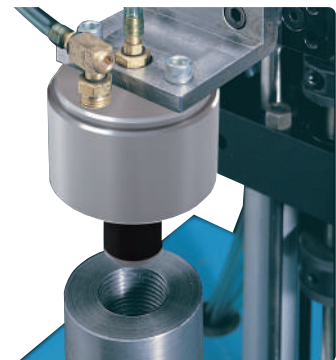

# » WEH<sup>®</sup> Connector TW01

## ORDERING | WEH<sup>®</sup> TW01 Quick connector

approx. dimensions (mm)

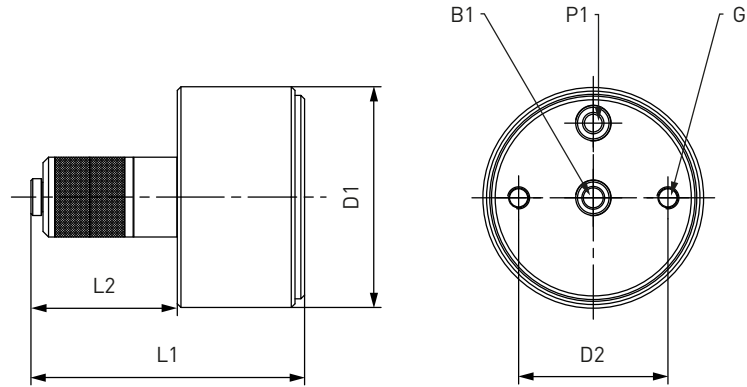

Body size	B1 (female thread)	P1 (female thread)	G**	D1	D2	L1	L2
01	M5	M5	M5	32.0	20.2	55.5	22.0
1	G1/8"	G1/8"	M6	40.0	26.0	70.5	28.0
2	G1/8"	G1/8"	M6	40.0	26.0	66.5	23.5
3	G1/8"	G1/8"	M6	60.0	41.0	74.5	40.0
4	G1/8"	G1/8"	M6	60.0	41.0	71.5	37.0
5	G1/2"	G1/8"	M6	89.0	60.0	106.5	59.5
6	G1/2"	G1/8"	M6	89.0	60.0	101.0	54.0
7	G3/4"	G1/8"	M6	107.0	76.5	94.0	57.5
8	G3/4"	G1/8"	M6	107.0	76.5	94.0	57.5

\* on request

\*\* thread for fixturing device

## » WEH® Connector TW01

### Straight tube, internal diameter

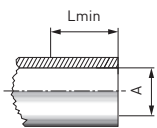

Part no. Connector	Part no. Main seal set	Part no. Replacement seals	Body size	Sealing range internal tube Ø A	Lmin*
C1-139903	B200B-141363	B200B-141298	01	7.7 - 8.3	13.5
C1-141179	B200B-141364	B200B-141299	01	8.4 - 10.0	13.5
C1-141180	B200B-141365	B200B-141300	1	10.0 - 12.0	15.0
C1-141181	B200B-141366	B200B-141301	1	12.0 - 14.0	15.0
C1-141182	B200B-141367	B200B-141302	1	14.0 - 16.0	15.0
C1-141183	B200B-141369	B200B-141303	2	16.0 - 18.0	15.0
C1-141184	B200B-141370	B200B-141304	2	18.0 - 20.0	15.0
C1-141185	B200B-141371	B200B-141305	2	20.0 - 22.0	15.0
C1-141186	B200B-141372	B200B-141306	3	22.0 - 24.0	28.0
C1-141187	B200B-141373	B200B-141307	3	24.0 - 26.0	28.0
C1-141188	B200B-141374	B200B-141308	3	26.0 - 28.0	28.0
C1-141189	B200B-141375	B200B-141309	4	28.0 - 30.0	28.0
C1-141190	B200B-141376	B200B-141310	4	30.0 - 32.0	28.0
C1-141191	B200B-141377	B200B-141312	4	32.0 - 34.0	28.0
C1-141192	B200B-141378	B200B-141313	5	34.0 - 37.0	41.0
C1-141193	B200B-141379	B200B-141314	5	37.0 - 40.0	41.0
C1-141194	B200B-141380	B200B-141315	5	40.0 - 43.0	41.0
C1-141195	B200B-141381	B200B-141316	6	43.0 - 47.0	41.0
C1-141196	B200B-141383	B200B-141317	6	47.0 - 51.0	41.0
C1-141197	B200B-141386	B200B-141318	6	51.0 - 55.0	41.0
C1-141198	B200B-141387	B200B-141319	7	55.0 - 58.5	41.5
C1-141199	B200B-141391	B200B-141321	7	58.5 - 62.1	41.5
C1-141200	B200B-141392	B200B-141322	7	62.1 - 65.6	41.5
C1-141201	B200B-141393	B200B-141323	8	65.6 - 69.2	41.5
C1-141202	B200B-141394	B200B-141324	8	69.2 - 72.7	41.5
C1-141203	B200B-141395	B200B-141325	8	72.7 - 76.0	41.5

\* Lmin: minimum insertion length of test piece  
Other connection sizes on request

### NPT thread (ANSI/ASME B1.20.1-1983) - acc. to SAE J476a

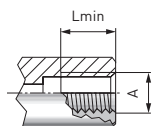

Part No. Connector	Part No. Main seal set	Part No. Replacement seals	Body size	Thread A (female thread)	Lmin*
C1-141430	B200B-141448	B200B-141440	01	NPT 1/8"	12.5
C1-141433	B200B-141450	B200B-141441	1	NPT 1/4"	14.5
C1-141434	B200B-141452	B200B-141442	2	NPT 3/8"	14.5
C1-141435	B200B-141453	B200B-141443	2	NPT 1/2"	14.5
C1-141436	B200B-141454	B200B-141444	3	NPT 3/4"	18.5
C1-141437	B200B-141455	B200B-141445	4	NPT 1"	18.5
C1-141438	B200B-141456	B200B-141446	5	NPT 1 1/4"	31.5
C1-141439	B200B-141458	B200B-141447	6	NPT 1 1/2"	31.5

\* Lmin: minimum insertion length of test piece

# » WEH® Connector TW01

Metric ISO-thread to DIN 13 - acc. to ISO 6149-1

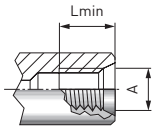

Part No. Connector	Part No. Main seal set	Part No. Replacement seals	Body size	Thread A (female thread)	Lmin*
C1-141459	B200B-141493	B200B-141476	01	M10x1.0	12.5
C1-141460	B200B-141494	B200B-141477	1	M12x1.5	14.5
C1-141461	B200B-141495	B200B-141478	1	M14x1.5	14.5
C1-141462	B200B-141496	B200B-141479	1	M16x1.5	14.5
C1-141463	B200B-141497	B200B-141480	2	M18x1.5	14.5
C1-141464	B200B-141498	B200B-141481	2	M20x1.5	14.5
C1-141465	B200B-141499	B200B-141482	2	M22x1.5	14.5
C1-141466	B200B-141500	B200B-141483	3	M24x1.5	18.5
C1-141467	B200B-141501	B200B-141484	3	M26x1.5	18.5
C1-141468	B200B-141502	B200B-141485	3	M27x2.0	18.5
C1-141469	B200B-141503	B200B-141486	3	M28x1.5	18.5
C1-141470	B200B-141504	B200B-141487	4	M30x1.5	18.5
C1-141471	B200B-141505	B200B-141488	4	M33x2.0	18.5
C1-141472	B200B-141506	B200B-141489	4	M36x2.0	18.5
C1-141473	B200B-141507	B200B-141490	5	M42x2.0	31.5
C1-141474	B200B-141508	B200B-141491	6	M48x2.0	31.5
C1-141475	B200B-141509	B200B-141492	7	M60x2.0	**

\* Lmin: minimum insertion length of test piece  
\*\* on request

SAE-O-Ring Boss - acc. to SAE J1926 / ISO 11926

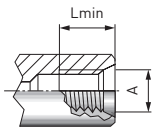

Part No. Connector	Part No. Main seal set	Part No. Replacement seals	Body size	Thread A (female thread)	Lmin*
C1-141901	B200B-141924	B200B-141913	01	UNF 7/16"-20	12.5
C1-141902	B200B-141925	B200B-141914	1	UNF 1/2"-20	14.5
C1-141903	B200B-141926	B200B-141915	1	UNF 9/16"-18	14.5
C1-141904	B200B-141927	B200B-141916	2	UNF 3/4"-16	14.5
C1-141905	B200B-141929	B200B-141917	3	UNF 7/8"-14	18.5
C1-141906	B200B-141930	B200B-141918	3	UN 1 1/16"-12	18.5
C1-141907	B200B-141931	B200B-141919	4	UN 1 3/16"-12	18.5
C1-141908	B200B-141932	B200B-141920	4	UN 1 5/16"-12	18.5
C1-141909	B200B-141933	B200B-141921	5	UN 1 5/8"-12	31.5
C1-141910	B200B-141934	B200B-141922	6	UN 1 7/8"-12	31.5
C1-141911	B200B-141935	B200B-141923	7	UN 2 1/2"-12	**

\* Lmin: minimum insertion length of test piece  
\*\*on request

Other connection types on request.

Required information for ordering see page 9.

## » WEH® Connector TW01

### ORDERING | WEH® TW01 Quick connector with shaft extension

approx. dimensions (mm)

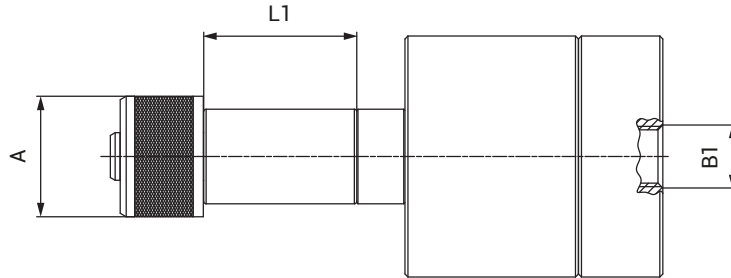

Part no.	Description	A	B1	L1
<b>On request</b>	TW01 with 1" extension	On request	On request	25.4
<b>On request</b>	TW01 with 2" extension	On request	On request	50.8

Shaft extensions in other lengths on request

### ACCESSORIES

The following accessories are available for the WEH® TW01 Quick connector:

Screw plug for plug version (see page 15)

#### Angle piece 90°

A 90° angle piece is available for applications requiring a 90° inlet for the pilot pressure. Connection 'P2' of the angle piece is connected to the pilot pressure port 'P1' of the connector and connection 'P1' of the angle piece is connected to the pilot pressure hose, hand slide valve or control/venting fitting.



Part no.	Description	P1	P2
<b>E69-9500</b>	Angle piece 90°	RP1/8**	R1/8***

\* cylindrical Whitworth tube thread acc. to DIN EN ISO 228-1

\*\* conical Whitworth tube thread acc. to DIN EN 10226

#### Accessories for manual actuation of the pilot pressure:

##### Pneumatic coupling and control/venting fitting

We offer a pneumatic coupling with control/venting fitting for manual actuation of the pilot pressure. Both are equipped with an integrated check valve. Connection 'P2' of the fitting is connected to the pilot pressure port 'P1' of the connector and connection 'P1' of the pneumatic coupling is connected to the pilot pressure hose. The pneumatic coupling is placed and held onto the control/venting fitting for manual actuation of the pilot pressure thus generating a short pressure impulse onto the fitting for actuation of the TW01 connector. Once actuated, the pneumatic coupling can be disconnected. The integrated check valve of the control/venting fitting ensures that the TW01 connector remains properly connected to the test piece and prevents any escape of the pilot medium. To disconnect the TW01 connector, actuate the check valve of the fitting manually, thus venting the pilot pressure applied.



Part no.	Description	P1 (female thread)	P2 (male thread)
<b>W136484</b>	Control/venting fitting	-	G1/8"
<b>W9326</b>	Pneumatic coupling	G1/8"	-

## » WEH<sup>®</sup> Connector TW01

### Hand slide valve and thread extension

Alternatively we also offer a hand slide valve for manual actuation of the pilot pressure. Connection 'P2' of the hand slide valve is connected to the pilot pressure port 'P1' of the connector and connection 'P1' of the hand slide valve is connected to the pilot pressure hose. The pilot pressure is applied or vented by actuating the sliding sleeve.

For small sizes and applications with restricted access where the hand slide valve cannot be connected directly to the pilot pressure port 'P1' of the connector, we also offer a thread extension.



Part no.	Description	P1 (female thread)	P2 (male thread)
<b>C1-48091</b>	Hand slide valve	G1/8"	G1/8"
<b>E69-96824</b>	Thread extension	G1/8"	G1/8"

### Seal sets



Main seal sets for non-threaded applications contain the elastomer main seal(s), two back up washers and a retaining ring for seal replacement.

Main seal sets for threaded applications contain the elastomer main seal(s), a seal mount, a front seal, two back up washers and a retaining ring for seal replacement.



Replacement seal sets contain five complete main seals with retaining rings.

### SPECIAL SOLUTIONS

Example:



TW01 with spacer for straight tubes



TW01 twin connector  
with manual actuation

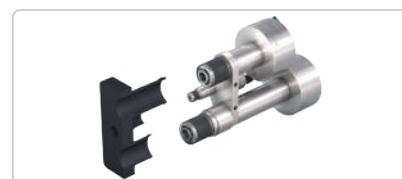

TW01 triple connector

## » WEH® Connector TW02

### DESCRIPTION



#### Features

- Connection in seconds
- No hand tightening required
- Sealing irregular or rough surfaces
- Simple seal replacement
- Ergonomic design
- High-grade materials

The WEH® TW02 Quick connector reliably and quickly seals tubes, hoses and male threaded components. Fitted with elastomer seals, the TW02 is ideal for sealing out of round and rough surfaces and clearing large tolerances on the test piece. The connector only clamps itself firmly over the sealing rubber of the test piece, but does not have any retaining function. Therefore a fixture must be used.

When using hose connections, WEH® TW02 is additionally equipped with a counterholder. Because of the pneumatic actuation, the connector is particularly well suited for automation of test procedures.

A number of accessories are available for manual actuation of the pilot pressure, e.g. hand slide valve or pneumatic coupling with control/venting fitting (see accessories). Special versions, e.g. twin connectors for sealing ports in close proximity to each other are available on request.

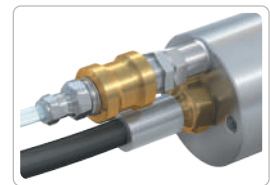

TW02 with hand slide valve

#### Application

Quick connector for pressure and vacuum testing of straight tubes, hoses and components with bead or collar (sealing on external tube diameter).

### TECHNICAL DATA

Characteristics	Basic version
Max. allowable operating pressure PS	Vacuum up to 35 bar
Pilot pressure	6 - 12 bar compressed air
Temperature range	+5 °C up to +80 °C
Leak rate	$1 \times 10^{-3}$ mbar x l/s
Material	Housing, piston and seal housing: aluminum
Sealing material	Main seal of chloroprene / o-rings of NBR For body size 001 main seal and o-rings of NBR. Urethane seals for high-wear applications are optional.

Other designs on request

**Note:** For pressurized applications the TW02 must be secured by a fixturing device. On vacuum applications the TW02 does not need to be secured. For operating pressures above 10 bar we recommend urethane seals.

#### Example of use:



# » WEH® Connector TW02

## ORDERING | WEH® TW02 Quick connector

approx. dimensions (mm)

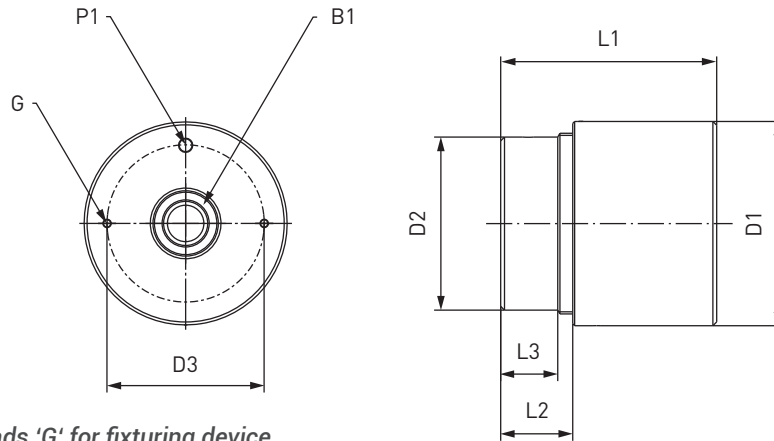

**Baugröße 001 - 3: 2 threads 'G' for fixturing device**

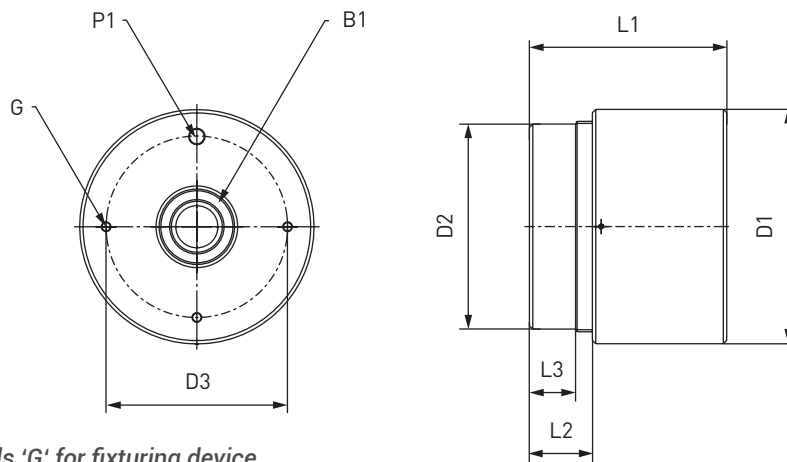

**Baugröße 4 - 6: 3 threads 'G' for fixturing device**

Body size	B1 (female thread)	P1 (female thread)	G**	D1	D2	D3	L1	L2	L3
001*	G1/8"	M5	M3	21.5	-	16.0	44.0	-	-
01	G1/8"	M5	M5	38.0	32.5	28.0	52.5	10.0	9.0
1	G1/4"	G1/8"	M6	56.5	47.0	41.5	69.5	10.0	8.5
2	G1/2"	G1/8"	M6	79.0	69.0	63.5	89.0	23.0	14.5
3	G1"	G1/8"	M6	107.5	91.0	82.5	114.0	38.0	29.5
4	G1 1/2"	G1/8"	M6	139.5	122.0	108.0	117.0	38.0	28.0
5	G2"	G1/8"	M10	177.5	162.0	140.0	117.0	35.5	35.5
6	G2 1/2"	G1/8"	M10	190.0	174.5	155.5	126.5	35.5	35.5

\* for body size 001, 'P1' is located on the diameter of the connector instead of on the face

\*\* thread for fixturing device

## » WEH® Connector TW02

### Straight tube, external diameter

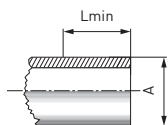

Part no. Connector	Part no. Main seal set	Part no. Replacement seals	Body size	Sealing range external tube Ø A	Lmin*
C1-141938	B200B-142085	B200B-142358	001	0.80 - 1.30	4.0
C1-141948	B200B-142090	B200B-142359	001	1.30 - 2.00	4.0
C1-141949	B200B-142091	B200B-142360	001	2.00 - 3.30	4.0
C1-141950	B200B-142092	B200B-142361	01	2.50 - 4.60	15.0
C1-141952	B200B-142094	B200B-142362	01	4.60 - 6.60	15.0
C1-141953	B200B-142095	B200B-142363	01	6.60 - 8.60	15.0
C1-141954	B200B-142096	B200B-142364	01	8.60 - 10.7	15.0
C1-141955	B200B-142097	B200B-142365	01	10.7 - 13.0	15.0
C1-141956	B200B-142098	B200B-142366	1	11.0 - 13.0	15.5
C1-141957	B200B-142099	B200B-142367	1	13.0 - 15.0	15.5
C1-141958	B200B-142100	B200B-142368	1	15.0 - 17.0	15.5
C1-141959	B200B-142101	B200B-142369	1	17.0 - 19.0	15.5
C1-141960	B200B-142102	B200B-142370	1	19.0 - 21.0	15.5
C1-141964	B200B-142120	B200B-142371	2	20.0 - 22.0	27.0
C1-141966	B200B-142121	B200B-142372	2	22.0 - 24.0	27.0
C1-141967	B200B-142122	B200B-142373	2	24.0 - 26.0	27.0
C1-141968	B200B-142123	B200B-142374	2	26.0 - 28.0	27.0
C1-141969	B200B-142124	B200B-142375	2	28.0 - 30.0	27.0
C1-141970	B200B-142125	B200B-142376	2	30.0 - 32.0	27.0
C1-141971	B200B-142126	B200B-142377	2	32.0 - 34.0	27.0
C1-141972	B200B-142127	B200B-142378	2	34.0 - 36.0	27.0
C1-141973	B200B-142128	B200B-142379	2	36.0 - 38.0	27.0
C1-141974	B200B-142129	B200B-142380	3	38.0 - 41.0	42.0
C1-141975	B200B-142130	B200B-142381	3	41.0 - 44.0	42.0
C1-141976	B200B-142131	B200B-142382	3	44.0 - 47.0	42.0
C1-141977	B200B-142132	B200B-142383	3	47.0 - 49.8	42.0
C1-141978	B200B-142133	B200B-142384	4	49.8 - 53.0	42.0
C1-141980	B200B-142134	B200B-142385	4	53.0 - 56.0	42.0
C1-141981	B200B-142135	B200B-142386	4	56.0 - 59.0	42.0
C1-141982	B200B-142136	B200B-142387	4	59.0 - 62.0	42.0
C1-141983	B200B-142137	B200B-142388	4	62.0 - 65.0	42.0
C1-141984	B200B-142138	B200B-142389	4	65.0 - 68.0	42.0
C1-141985	B200B-142139	B200B-142390	4	68.0 - 71.0	42.0
C1-141986	B200B-142140	B200B-142391	4	71.0 - 74.0	42.0
C1-141987	B200B-142141	B200B-142392	4	74.0 - 77.0	42.0

\* Lmin: minimum insertion length of test piece  
Other connection sizes on request

Other connection types on request.

Required information for ordering see page 9.

## » WEH<sup>®</sup> Connector TW02

---

### ACCESSORIES

---

The following accessories are available for the WEH<sup>®</sup> TW02 Quick connector:

Screw plug for plug version (see page 15)

Angle piece 90° (see page 77)

**Accessories for manual actuation of the pilot pressure:**

Pneumatic coupling and control/venting fitting (see page 77)

Hand slide valve and thread extension (see page 77)

### Seal sets

---



Main seal sets contain the elastomer main seal(s) and back-up washers for one seal replacement.



Replacement seal sets contain five complete main seals.

### SPECIAL SOLUTIONS

---

Example:



TW02 for rubber hose testing



TW02 with extension  
for plastic hose nozzles



TW02 twin connector

## » Fuel connectors for the automotive industry

The WEH® Connectors enjoy an international reputation in the automotive industry and are used world-wide. They have been successfully used on engine test facilities for fast and efficient pressure and leak tests on fuel lines while maintaining production rates.

### TW710

Quick connector with lateral test port for tubes with bead or collar (very short version)



### TW711

Quick connector with central test port for tubes with bead or collar



### TW712

Quick connector with lateral test port for tubes with bead or collar



### TW713

Quick connector with central test port for tubes with bead or collar and pneumatic actuation for automated application



### TW714

Quick connector with central test port for 'John-Guest-Connections'



### TW723

Quick connector with central test port for tubes with bead, collar or external thread



### TW850

Quick connector for testing of diesel injectors up to 2,600 bar

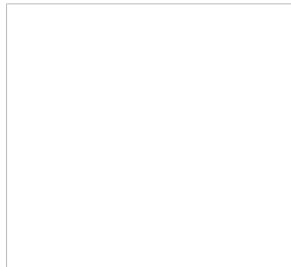

We will also develop a suitable solution for your specific needs, please contact us!

## » Customer-tailored solutions

In addition to their extensive range of products, WEH - a world specialist in connection technology - can also meet customer's special requirements with innovative solutions. Wherever pressure-tight connections have to be established and testing procedures automated, we can supply the right solution for your application. Working in collaboration with our customers on demanding applications is our speciality. Our portfolio of advanced connector solutions provides ample evidence of the innovative technology of WEH® Products.

The following application provides an exemplary insight into the world of our special developments:

### TW17V twin connector

Twin connector for pressure testing threaded ports with centres that are very close to each other



### TW17P with extension

Quick connector with extension for pressure testing components with internal thread

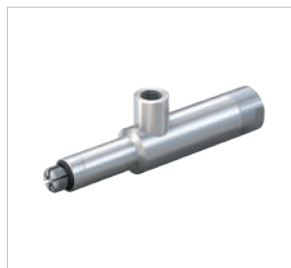

### TW01 twin connector

Twin connector for pressure testing bores that are very close to each other



### TW02 twin connector

Twin connector for pressure and flow testing straight tubes that are very close to each other



### TW03 with extension

Quick connector with extension for pressure testing components with internal thread that have space envelope restraints



### TW751

Testing of pressure gauges up to 1,000 bar



We will also develop a suitable solution for your specific needs, please contact us!

## » Technical appendix

### Definitions

Abbreviation	Definition	
<b>Pressure specifications</b>	<i>(all pressure specifications are to be understood as overpressure, unless otherwise stated)</i>	
PN	Nominal pressure	Nominal pressure after temperature compensation at 15 °C (59 °F)
PS	Max. allowable operating pressure	Maximum allowable operating pressure acc. to Pressure Equipment Directive 2014/68/EU, Article 2 paragraph 8
PT	Hydrostatic test pressure	Hydrostatic test pressure acc. to Pressure Equipment Directive 2014/68/EU, Annex I no. 7.4
PP	Pilot pressure	Actuation pressure for hydraulic and pneumatic components
PC	Cracking pressure	Pressure at which the check valve opens and the first indication of flow occurs
WP	Working pressure	'Working pressure' means the maximum pressure to which a component is designed to be subjected to and which is the basis for determining the strength of the component under consideration
MAWP	Max. allowable working pressure	Max. allowable operating pressure at which the weakest point of the system or the vessel (e.g. cylinder valve) can operate at a certain temperature during normal operation
<b>Dimensions</b>		
L1, L2, L3 ...	Length specification	
D1, D2, D3 ...	Diameter specification	
A/F(1), A/F(2) ...	Wrench size specification	
<b>Ports</b>		
A / X	Customer-specific port (test piece, sample, cylinder valve, handwheel respiratory protective equipment)	
B1, B2, B3 ...	Media ports	
C1, C2, C3 ...	Gas recirculation ports	
P1, P2, P3 ...	Pilot pressure ports	
MA1, MA2 ...	Measuring ports	
Q	Drain port filter	
G	Mounting bores	
<b>Others</b>		
DN	PED-nominal size (DN)	Nominal size (DN) acc. to Pressure Equipment Directive 2014/68/EU, whereby the largest, pressurized diameter of the media or pilot pressure connections of the WEH Device (A, B1, B2, B3 or C1, C2, C3 and P1, P2, P3) which faces the customer's pipe system, is relevant. Expressed by a rounded, dimensionless number, e. g. DN 25
TNW	Technical nominal size	The technical nominal size (formerly expressed by "effective diameter") is the smallest diameter available for the media flow of the respective pressure device. Expressed by a number with unit, e. g. 12 mm
µm	Max. diameter of the filtered particle	
Kv	Is the discharge of water in m <sup>3</sup> /h at a pressure drop of 1 bar (14.5 psi), acc. to DIN/EN 60534-2	
Cv	Is the discharge of water in gallons per minute at a pressure drop of 1 psi, acc. to DIN/EN 60534-2	
IR	Infrared data interface	
ENR	Exchangeable data interface (exchangeable nozzle receiver)	

## » Technical appendix

### Definitions

Abbreviation	Definition
TS	Maximum allowable temperature acc. to Pressure Equipment Directive 2014/68/EU, Article 2 paragraph 9
Breakaway force	Is the force range, in which the breakaway releases
NC	Normally closed (initial position of shut-off valve)
NO	Normally open (initial position of shut-off valve)

### Technical explanations

Term	Definition
Temperature range	Is the temperature range in which the WEH® Product can be used. If no explicit information on medium and ambient temperature is given, this temperature range applies to both medium and environment.
Media temperature range	Is the temperature range of the medium used, which can flow through the WEH® Product (may change depending on the time of measurement).
Ambient temperature range	Is the temperature range of the environment in which the WEH® Product can be used.
Leak rate	Is the maximum external leak rate, which the WEH® Product exhibits in delivery condition.
Internal leak rate	The internal leak rate depends, among other things, on type of application, medium and pressure difference on the WEH® Product. On request it can be specified more precisely.
Max. side load	Is the max. allowable sum of all external forces that may act on the device under intended use. <b>Note:</b> External forces can affect the life time of WEH® Products and can cause damage. Tensile and transverse loads as well as vibrations and pressure impacts need to be considered, e.g. by user side measures such as on site mountings and similar. Therefore, lateral forces such as whipping hoses or other equipment must be avoided. WEH® Products should be installed in such a way, that lateral forces which could lead to leakage or damage can not occur. Special applications require a special consultation before selecting the product.
Products with pneumatic actuation	The customer has to ensure there is adequate axial movement when pneumatically actuated WEH® Products are used in automated systems, see maximum side load. Ideally the products should be mounted with a floating joint or introduced individually to prevent the possibly existing clamping jaws getting blocked or jammed in the thread of the test piece.
Sealing material	On request the WEH® Product can be adapted to customer specific applications regarding to the sealing materials used. The clarification of the media compatibility and suitability of the adapted WEH® Product for the final application is always the responsibility of the end user.
Corrosion resistant	WEH® Products are designed for use in temperate climate zones - with low levels of humidity and salinity in the air. An accelerated formation of rust or corrosion may occur at or near the sea. Therefore, reduce the inspection interval recommended for normal use and send in the WEH® Product for maintenance immediately if you notice increased soot, rust or corrosion.
Storage / life time of components	There are certain requirements for every WEH® Product. WEH® Products are generally products which may be subject to wear and fatigue during operation and depending on your individual application/use. For details - in particular regarding the corresponding minimum inspection and maintenance intervals – please refer to the respective operating instructions for the WEH® Product.

## » Technical appendix

### Further explanations

Subject	Definition
Technical data	Unless otherwise stated, the technical data in catalogs, data sheets and operating instructions are based on tests with nitrogen that are in the development phase or at the end of development. Leakage data are based on measurements with helium.
Intended use	<p>The intended use of WEH® products can be found in the respective operating instructions. The following applications are generally excluded for all WEH® products, unless these are expressly permitted in the operating instructions:</p> <ul style="list-style-type: none"> <li>• applications in the aerospace industry, e.g. for installation or use in or for the construction of aircraft, rocket propulsion systems, space probes, satellites, etc.</li> <li>• shipping applications</li> </ul>
Safe product selection	<p>Our WEH® Products are designed to be operated by qualified professional users (insofar as WEH® Products are also designed to be operated by other users in individual cases, this is explicitly stated in the corresponding operating instructions). Please note that WEH does not know your system and therefore - also due to the large number of different potential applications of WEH® Products - cannot perform tests on all potential types of application. You alone are responsible for the selection, configuration and suitability of WEH® Products, especially according to the requirements of your system. Before purchasing WEH® Products, please particularly ensure that our products are compatible with your intended use, your performance data, your material and fluids, your system concept and your system limits according to our product specifications. Please also consider your technical and legal requirements for operation, handling and maintenance. The quality and safety of WEH® Products is our highest priority. For this reason, WEH® Products may not be used outside the specifications in the relevant data sheets and product descriptions. If you are not sure whether the WEH® Product is suitable for your system and intended use, please contact us in advance. We also strongly recommend that you refrain from using third-party spare parts or a combination of WEH® Products with unsuitable third-party products. You alone are responsible for reviewing the suitability of third-party products. WEH® Products and WEH® Spare parts comply with our quality and safety standards.</p>
Explanation on the Pressure Equipment Directive	<p>In general, WEH® Products with a maximum allowable operating pressure of more than 0.5 bar (PS) fall within the scope of application of the Pressure Equipment Directive 2014/68/EU, are generally classified as pressure accessories in accordance with Article 2 (5) of the same and are considered to be similar to piping. These WEH® Products may not be used as safety accessories. Furthermore, it is pointed out, that these WEH® Products are designed and placed on the market in accordance with the requirements of Article 4 (3) of the Pressure Equipment Directive 2014/68/EU.</p> <p>For some products a different classification and/or categorisation is required or can be conducted on request. In these cases, if legally required, a conformity assessment procedure in accordance with Annex III of the Pressure Equipment Directive 2014/68/EU can and will also be conducted and the conformity can be declared by means of an EU Declaration of Conformity in accordance with Annex IV of the Pressure Equipment Directive 2014/68/EU. In these cases, the EU Declaration of Conformity is enclosed with the product.</p>
External change management	WEH reserves the right to update, optimise and adjust its products continuously. This may result in corresponding changes of the product. Customers will be informed proactively or unsolicited by WEH only in individual cases about product updates, product optimisations and/or product adaptations that have been carried out. You are free to contact WEH at any time to request information about any product updates, product optimisations and/or product adjustments.

## » Brochure data

---

This catalog was created diligently and on the basis of decades of experience.

All information/recommendations in this catalog are non-binding and are particularly subject to possible deviations or changes. For any binding information/recommendations, please refer to the verified information/recommendations in our individual orders. Particularly, due to the wide range of possible applications of WEH® Products and the unknown parameters and operating conditions linked to them, the accuracy and/or completeness of the information/recommendations in this catalog cannot be guaranteed with respect to certain individual cases. In doing so, we would like to refer once again to the information/recommendations provided in individual orders.

The application limits indicated in this catalog (e.g. for pressure, temperature, etc.) are generally theoretical values determined in a test environment. As the concrete operating conditions could differ, we cannot ensure that these values apply to a specific customer application. During the practical use, you should particularly consider that the mutual influence of operational parameters could result in changes of the maximum values. Especially, in case of any unusual operating conditions, please contact WEH before using any WEH® Products. We therefore strongly recommend that you also require any necessary binding information/recommendations to be included by us in the individual orders.

Furthermore, we point out that we cannot assume any warranty or accept any responsibility for printing errors, incomplete information or misinterpretations. Illustrations and/or images are particularly provided for illustrative purposes only and may differ in some details from the actual product. Moreover, dimensions and other technical details in this catalog are non-binding information and are provided for illustrative purposes only. The product's exact form and design result exclusively from the specific individual order. In particular, certain information/recommendations in the catalog only become integral part of the contract if they have been expressly contractually agreed.

Only the latest version of our catalog and other product related documents is valid and applicable. Please ensure that you always use the latest catalog's and documents' versions. Please feel free to contact WEH at any time and request the latest versions.

Our General Terms and Conditions and the Agreement on Protection of Know-How and Quality Assurance shall apply to deliveries and other services, unless expressly agreed otherwise.

In principle, we do not accept the General Terms and Conditions of our customers or third parties. Thank you for your understanding.

---

**WEH GmbH Verbindungstechnik**  
Josef-Henle-Str. 1  
89257 Illertissen / Germany

Phone: +49 7303 9609 703  
E-Mail: [industry@weh.com](mailto:industry@weh.com)  
Website: [www.weh.com](http://www.weh.com)

**More questions? – Great! Don't hesitate to contact our experts.**