

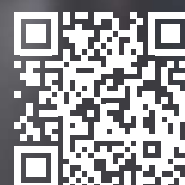

WEH[®] H₂ Refueling

High-performance components
for hydrogen vehicles and fueling stations



**To the current
catalog version:**



© All rights reserved, WEH GmbH Verbindungstechnik.

Any unauthorized copying, distribution, or other use of the copyrighted content is prohibited without the written consent of WEH GmbH Verbindungstechnik.

With the transmission of a more recent version of this document, all older versions lose their validity. The most recent version of the document applies. This can be found at www.weh.com/downloads.

Unless expressly agreed otherwise, our General Terms and Conditions and the Know-How Protection and Quality Assurance Agreement (www.weh.com) apply to all deliveries and other services.

We do not recognize the customer's general terms and conditions.

WEH® is a registered trademark of WEH GmbH Verbindungstechnik.

» Table of contents

1 H₂ fueling components	6
1.1 Introduction	6
1.2 Overview	10
2 Product line 70 MPa fueling station	14
2.1 Fueling nozzle TK20-S1 H ₂ 70 MPa ENR	14
2.2 Fueling nozzle TK20-S1 H ₂ 70 MPa	20
2.3 Breakaway coupling TSA30-S1 H ₂ 70 MPa	24
2.4 Breakaway coupling TSA31-S1 H ₂ 70 MPa	28
3 Product line 70 MPa vehicles (fueling station)	32
3.1 Receptacle TN9-S1 H ₂ 70 MPa	32
3.2 Check valve TVR9 H ₂ 70 MPa	36
3.3 Check valve TVR1 H ₂ 70 MPa	38
4 Product line 35 MPa fueling station	40
4.1 Fueling nozzle TK20-S2 H ₂ 35 MPa ENR	40
4.2 Fueling nozzle TK20-S2 H ₂ 35 MPa	44
4.3 Fueling nozzle TK20-S3 H ₂ 35 MPa ENR Medium-Flow	48
4.4 Fueling nozzle TK20-S2 H ₂ 35 MPa Medium-Flow	52
4.5 Fueling nozzle TK16 H ₂ ENR	56
4.6 Fueling nozzle TK16 H ₂	60
4.7 Fueling nozzle TK16 H ₂ High-Flow with data interface	64
4.8 Fueling nozzle TK16 H ₂ High-Flow	68
4.9 Breakaway coupling TSA1 H ₂	72
4.10 Inline breakaway coupling TSA2 H ₂	78
4.11 Fueling nozzle TK25 H ₂	82
4.12 Breakaway coupling TSA5 H ₂	86
4.13 Inline breakaway coupling TSA6 H ₂	90

» Table of contents

5 	Product line 35 MPa vehicles (fueling station)	92
5.1	Receptacle TN9-S2 H ₂ 35 MPa	92
5.2	Receptacle TN9-S3 H ₂ 35 MPa Medium-Flow	96
5.3	Receptacle TN1 H ₂	100
5.4	Receptacle TN1 H ₂ Medium-Flow	104
5.5	Receptacle TN5 H ₂	108
5.6	Check valve TVR1 H ₂	110
5.7	Check valve TVR5 H ₂	112
6 	Filter vehicle and fueling station	114
6.1	Filter TSF2 H ₂	114
6.2	Coalescing filter TSF2 H ₂	118
6.3	Filter TSF4 H ₂	120
7 	Accessories	122
7.1	Defueling nozzle TK6 H ₂	122
7.2	H ₂ Hoses	126
7.3	Service receptacle TNS12-S1 H ₂	130
7.4	Quick connector TW850-S60 H ₂	134
7.5	Manifold TMF900-S1 H ₂	138
8 	Further information	140
8.1	Technical appendix	140
8.2	Brochure data	143

» Introduction

WEH[®] H₂ Fueling components

Excellent quality for maximum reliability





WEH & Hydrogen

Passion with experience

WEH recognized early on that the regenerative energy source hydrogen has a future and developed the first hydrogen refueling components more than 25 years ago.

As a pioneer, WEH set international standards.

Today, hydrogen fueling stations and fuel cell vehicles all over the world are almost exclusively equipped with WEH[®] refueling components.

We are a reliable partner to many industries

Thanks to intensive research and development, WEH has become a reliable and highly valued partner to the automotive industry in this cutting-edge technology. Our products can easily withstand pressures of up to 1,000 bar. Because high pressure has always been our passion.

WEH high-pressure components also impress with their reliability and safety in many other sectors, such as mechanical engineering, the chemical and gas industry, refrigeration and air conditioning technology.

Everything from a single source with WEH

Today, WEH develops, produces and distributes a complete product line for hydrogen refueling. From filling couplings, breakaway couplings, filling hoses and filters at the filling station to tank nipples and non-return valves in the vehicle.

WEH's innovative refueling solutions have contributed to a much better acceptance in society. Our product solutions are a healthy mix of innovation and tradition and ensure that the driver has a familiar refueling experience.

We focus on the future

Driven by our passion, intensive research and extensive investments, we continue to work on innovative products for the future market of hydrogen refueling.



Our **Mission**

For more than 25 years, we have been developing future-oriented H₂ refueling technology solution. Pioneering is deep in our DNA, so when it comes to hydrogen: we lead at the frontier.

Our **Goal**

We strive to meet (and delightfully exceed) our customers' expectations--from design to service. By consistently delivering high-quality, safe and user-friendly products, this goal has grown to become our promise.



Innovative H₂ Products for real-world applications

Our product solutions touch all aspects of the refueling process. Receptacles, check valves and filters for vehicles. H₂ systems, 'up to fueling' nozzles, breakaway couplings, filters, check valves and hoses for fueling stations. Whatever your hydrogen need, we have you covered.

WEH[®] H₂ Components Your benefits

- ▶ Balanced design
- ▶ Unique user-friendliness
- ▶ Highest functionality and safety
- ▶ Reliability & efficiency
- ▶ High flow rate
- ▶ Short filling times
- ▶ Optimum protection for operators and components
- ▶ Minimal downtime
- ▶ Low maintenance requirements
- ▶ Robust & durable



Our Core Competencies

-  **Global Sales Network**
Active in 60+ countries
-  **Passion for High-Pressure**
Components for multiple industries
-  **World-Class Engineering**
To meet specific product needs on request
-  **In-house Test Center**
Extensive testing during development
-  **Pioneers – We set the Standard**
Trailblazing product solutions
-  **Goods Issue Inspection**
We inspect each product individually
-  **50+ years Experience**
More than 25 of those spent innovating in the hydrogen sector
-  **Quality – Made in Germany**
ISO 9001:2015
ISO 14001:2015
Pressure Equipment Directive 2014/68/EU Annex III, Module H
-  **Environmental Management**
Sustainable products and actions
-  **Service & Maintenance**
Directly from the manufacturer
-  **Maximum Safety**
Through exceptional products and high-quality materials

Sophisticated systems

for a demanding application
The WEH[®] hydrogen product line was developed to meet the requirements of high pressures in the refueling area. All components are designed to withstand extreme flow rates and temperature conditions.

Test laboratory

Modern testing facilities guarantee comprehensive testing of our products from the design phase through to series production. Our 100 % quality assurance is second to none.

Unique jaw locking mechanism

All filling couplings have the jaw locking mechanism developed by WEH. The collets are insensitive to contamination and the low surface pressure minimizes wear.

More safety through filter technology

Our integrated dirt filter prevents dirt particles ingress of dirt particles from the outside in order to leaks as far as possible.

The right decision with certainty

WEH[®] hydrogen products have a high safety standard. This is the only way self-service operation is even possible.

» Overview

FUELING NOZZLES / BREAKAWAY COUPLINGS

And their common uses:

Overview fueling nozzles					
Product family	Page	Car		Bus/truck	
TK20-S1 H ₂ 70 MPa ENR	14	<input checked="" type="checkbox"/>		<input checked="" type="checkbox"/>	
TK20-S1 H ₂ 70 MPa	20	<input checked="" type="checkbox"/>			
TK20-S2 H ₂ 35 MPa ENR	40	<input checked="" type="checkbox"/>			
TK20-S2 H ₂ 35 MPa	44	<input checked="" type="checkbox"/>			
TK20-S3 H ₂ 35 MPa ENR Medium-Flow	48			<input checked="" type="checkbox"/>	
TK20-S3 H ₂ 35 MPa Medium-Flow	52			<input checked="" type="checkbox"/>	
TK16 H ₂ 35 MPa ENR	56	<input checked="" type="checkbox"/>			
TK16 H ₂ 35 MPa	60	<input checked="" type="checkbox"/>			
TK16 H ₂ High-Flow with data interface	64			<input checked="" type="checkbox"/>	
TK16 H ₂ High-Flow	68			<input checked="" type="checkbox"/>	
TK25 H ₂	82			<input checked="" type="checkbox"/>	

Overview defueling nozzles		
Product family	Page	Discharging of H ₂ fuel tanks - car
TK6 H ₂	122	<input checked="" type="checkbox"/>

Overview breakaway couplings					
Product family	Page	Car	Car - Inline	Bus/truck	Bus/truck - Inline
TSA30-S1 H ₂ 70 MPa	24	<input checked="" type="checkbox"/>			
TSA31-S1 H ₂ 70 MPa	28		<input checked="" type="checkbox"/>		<input checked="" type="checkbox"/>
TSA1 H ₂	72	<input checked="" type="checkbox"/>		<input checked="" type="checkbox"/>	
TSA2 H ₂	78		<input checked="" type="checkbox"/>		<input checked="" type="checkbox"/>
TSA5 H ₂	86			<input checked="" type="checkbox"/>	
TSA6 H ₂	90				<input checked="" type="checkbox"/>

FILTERS

Overview filters					
Product family	Page	Car	Bus/truck	Car fueling station	Bus/truck fueling station
TSF2 H ₂	114	<input checked="" type="checkbox"/>	<input checked="" type="checkbox"/>	<input checked="" type="checkbox"/>	<input checked="" type="checkbox"/>
TSF2 H ₂ Koaleszenz	118	<input checked="" type="checkbox"/>	<input checked="" type="checkbox"/>	<input checked="" type="checkbox"/>	<input checked="" type="checkbox"/>
TSF4 H ₂	120	<input checked="" type="checkbox"/>	<input checked="" type="checkbox"/>	<input checked="" type="checkbox"/>	<input checked="" type="checkbox"/>

» Overview

PRESSURE RANGE / CODING

All WEH® Fueling nozzles and receptacles have a coding for gas type and the pressure range thus not allowing connection to natural gas vehicles and other pressure ranges. The following connection possibilities are given:

OVERVIEW	Receptacle	TN1 H25	TN9-S2 H35 TN1 H35	TN9-S3 H35 Medium-Flow TN1 H35 Medium-Flow	TN9-S1 H70	TN5 H35
Fueling nozzle	Pressure PN	25 MPa	35 MPa	35 MPa	70 MPa	35 MPa
TK16 H ₂	25 MPa	✓	✓	✓	✓	
TK16 H ₂ 35MPa TK16 H ₂ 35 MPa ENR**	35 MPa		✓	✓	✓	
TK16 H ₂ High-Flow TK16 H ₂ High-Flow with IR*	35 MPa			✓		
TK20-S2 H ₂ 35 MPa TK20-S2 H ₂ 35 MPa ENR**	35 MPa		✓	✓	✓	
TK20-S3 H ₂ 35 MPa Medium-Flow TK20-S3 H ₂ 35 MPa ENR** Medium-Flow	35 MPa			✓		
TK20-S1 H ₂ 70 MPa TK20-S1 H ₂ 70 MPa ENR**	70 MPa				✓	
TK25 H ₂	35 MPa					✓

* IR = Infrarot-Datenschnittstelle / ** ENR = austauschbare Infrarot-Datenschnittstelle

Note on ISO 17268-1:2025 Standard:

With the publication of ISO 17268-1:2025, the designation and coding of the H35 High-Flow receptacles and nozzles will change. The applicable coding for each product is specified in the respective article.

Our new products, the TK20 Fueling nozzle and TN9 Receptacle, already comply with the updated coding according to ISO 17268-1:2025. For the TK16 Fueling nozzle and TN1 Receptacle, the coding is still based on ISO 17268:2012.

If you have any questions, our Sales Team will be happy to assist you.

INTERNATIONAL STANDARDS AND APPROVALS

The following overview shows the standards for which WEH® Products can be certified. For detailed information see respective product.

- Regulation (EC) No. 79/2009*
- ISO 17268
- SAE J2601
- ATEX, NEC, KTL, CCC

* All products with EC79 approval are also suitable for use in stationary systems.

When using the products in stationary systems, please check the necessity of a conformity assessment procedure acc. to the Pressure Equipment Directive 2014/68/EU and contact us if corresponding documentation is required. Please also refer to the note on page 116, Explanation on the Pressure Equipment Directive.

For reasons of precaution, we'd like to point out that

- regarding the delivery of each article acc. to the respective order confirmation - in particular concerning ECE / EC79 articles - WEH does not confirm the fulfilment of additional requirements of the concerned end customer,
- WEH is not subject to any external reporting obligation with regard to external change management (see page 114) and
- WEH does not confirm the replacement of the product in the form of a regular series delivery. Exclusions acc. to a) - c) can be agreed with the conclusion of a customer-specific project with corresponding special conditions.

» Overview

CERTIFIED QUALITY MANAGEMENT

Our high quality standards are achieved by a practiced quality management and confirmed by certification according to international quality standards.



Quality Management System
DIN EN ISO 9001:2015



Environmental Management System
DIN EN ISO 14001:2015

MEMBERSHIPS

WEH is a member of the German Hydrogen and Fuel Cell Association and the Hydrogen.Bavaria Center (H2.B).



» Projects

OUR COMMITMENT TO AN EMISSION-FREE FUTURE

Today, WEH is the global market leader with its refueling systems and a partner to the automotive industry. In addition, WEH is involved in numerous national and international projects worldwide to promote alternative drives and is therefore also a driving force for a mobile society with a future.

We present three of these exciting projects here. They are examples of numerous inquiries and our commitment, which we are happy to continue.



Full throttle on the race track

We are involved in numerous projects around the world to promote alternative fuels in order to realize a climate-neutral future and environmentally friendly mobility.

Among other things, we support the Forze racing team of the Dutch University of Delft with 70 MPa components for a hydrogen-powered racing car.



Hydrogen on the water

The Dutch HydroMotion team at Delft University has developed the first hydrogen boat "Flying Hydrogen Boat". As a leading manufacturer of refueling components for hydrogen, we were delighted to support the student project.

We have provided these WEH® products free of charge:

- ▶ WEH® Check Valve TVR1 H₂
- ▶ WEH® Receptacle TN1 H₂

The Yacht Club has awarded the HydroMotion team the "Next Generation Prize" for this innovative and progressive project.



With pressure on the rails

The world's first hydrogen train for regional transportation was unveiled in 2016. It runs near Bremerhaven.

The "Coradia iLint" train developed by the French train manufacturer Alstom is equipped with WEH® TN1 H₂ 35 MPa receptacle. On the roof of the train, the fuel cells convert the hydrogen carried in the tank hydrogen into electrical energy and thus provide the propulsion. The train is of course refueled using the WEH® TK16 H₂ 35 MPa fueling nozzle.

» Fueling nozzle TK20-S1 H₂ 70 MPa ENR



DESCRIPTION



Features

- Type C nozzle acc. to SAE J2600 resp. ISO 17268
- Very high flow rate
- Easy operation / single-handed operation
- Max. allowable operating pressure (MAWP according to ISO 19880-1:2020)
- Exchangeable data interface (ENR)
- Integrated purging line for nitrogen flushing
- Prepared for dispenser mounting with purging system
- WEH® EASY-TURN 250° swivel joint
- Protection against impact and cold
- Plastic thermal protection
- Hand grip with magnet
- Compatible with pressure stage H70 according to ISO 17268 (see table below)

The WEH® TK20-S1 H₂ 70 MPa ENR Fueling nozzle with exchangeable data interface (ENR = exchangeable nozzle receiver) was developed for fast filling of cars with compressed, gaseous hydrogen (CGH₂). Through to the larger nominal width, refueling with 90 g/s or higher is possible. In addition, this filling coupling is designed for a maximum operating pressure of 96.25 MPa (= MAWP according to ISO 19880-1:2020).

In addition, the new TK20-S1 H₂ 70 MPa ENR has the same tried and tested features as the already well-known TK17 H₂ 70 MPa ENR. The fueling nozzle is additionally equipped with a purging line that allows purging with nitrogen during and after refueling process. This can prevent ingress of moisture and the formation of ice crystals during filling with precooled.

The WEH® TK20-S1 H₂ 70 MPa ENR offers optimum safety for the operator thanks to the locking mechanism. The Fueling nozzle remains connected to the receptacle until the locking mechanism is released by the operator.

Application

Fueling nozzle for hydrogen fast filling of cars at self-service fueling stations.

		TN H ₂ (Except TN5 H ₂)				
		25 MPa	35 MPa	35 MPa MF*	35 MPa HF**	70 MPa
TK20-S1 H ₂ 70 MPa ENR	70 MPa					✔
	70 MPa					

*MF = Medium-Flow acc. to ISO 17268-1:2025
**HF = High-Flow acc. to ISO 17268:2012

» Fueling nozzle TK20-S1 H₂ 70 MPa ENR

TECHNICAL DATA

Characteristics	Basic version
Flushing line male / female thread	6/4 mm
Nominal pressure	PN = 70 MPa
Max. Allowable Operating Pressure	MAWP = 96.25 MPa according to ISO 17268 (PS = 962.5 bar)
Media Temperature Range	-40°C up to +85°C
Ambient Temperature Range	-40°C up to +85°C
Material	Corrosion resistant
Sealing Material	Hydrogen resistant
Nozzle Type	Type C acc. to SAE J2600:2015 and previous resp. ISO 17268:2020 and previous
Coding	H70 Grade D acc. to ISO 17268-1:2025
Design	With plastic thermal protection, cold protection, hand grip with magnet, exchangeable data interface acc. to SAE J2799 and integrated purging line
Weight	Approx. 2.65 kg
Medium for Purging*	Nitrogen or compressed air
Media Temperature Range Purging Medium*	-40°C to +85°C (most effective above 0°C)
Hydrogen flow rate	90 g/s at 8 MPa pressure drop (F90-P8) Pressure drop values for 120 g/s on request
Flow Rate During Purging	500 NI/h at max. 12 bar purging pressure
Conformity / Tests / Approvals	IR data interface: SAE J2799 and ATEX, NEC, KTL or CCC Design validation based on ISO 17268-1:2025

* The efficiency of the purging line has been successfully tested in compliance with the freezing test 7,26 from ISO 17268

» Fueling nozzle TK20-S1 H₂ 70 MPa ENR

ORDERING | WEH® TK20-S1 H₂ 70 MPa ENR Fueling nozzle

approx. dimensions (mm)

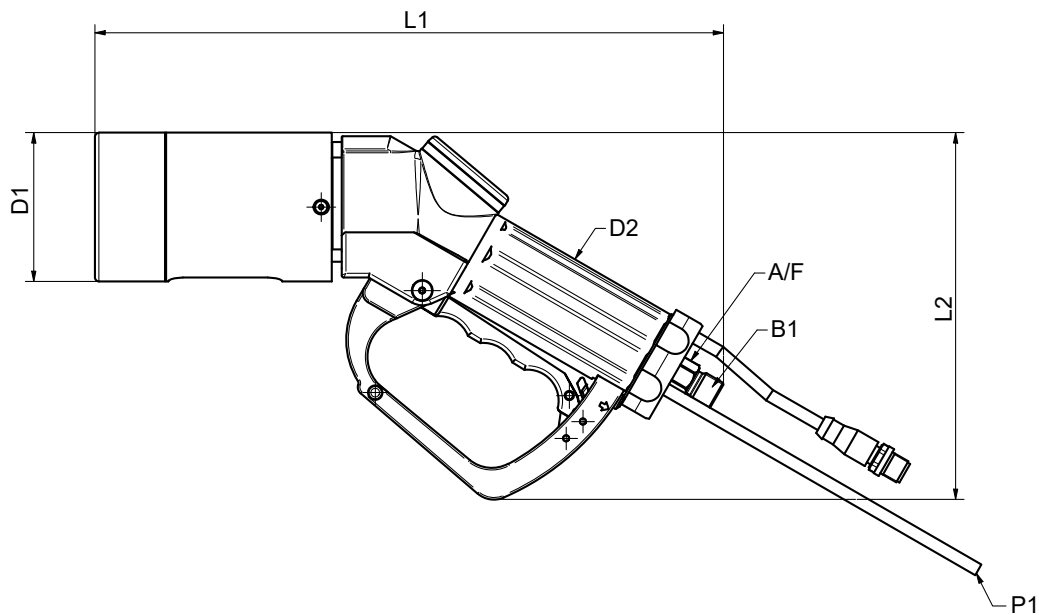

Part no.	Description	Pressure (MAWP)	B1 (male thread)	P1	L1	L2	D1	D2	A/F
C1-188722	TK20-S1 H ₂ 70 MPa ENR	96.25 MPa	UNF 9/16"-18*	Ø 6	304	177	72	46	15

* 60° inner cone

Fueling assemblies consisting of fueling nozzle, hose set and breakaway coupling are available on request.

» Fueling nozzle TK20-S1 H₂ 70 MPa ENR

ACCESSORIES TK20-S1 H₂ 70 MPa ENR

The following accessories are available for the WEH® TK20-S1 H₂ 70 MPa ENR Fueling nozzle:

Complete set consisting of Fueling nozzle TK20-S1, Breakaway coupling TSA30-S1 and Hose set

The TK20-S1 Complete set set new standards: thanks to improved flow characteristics, it offers a 40 % lower pressure drop at a flow rate of 90 g/s.



Part. no.	Description
On request	Complete set TK20-S1

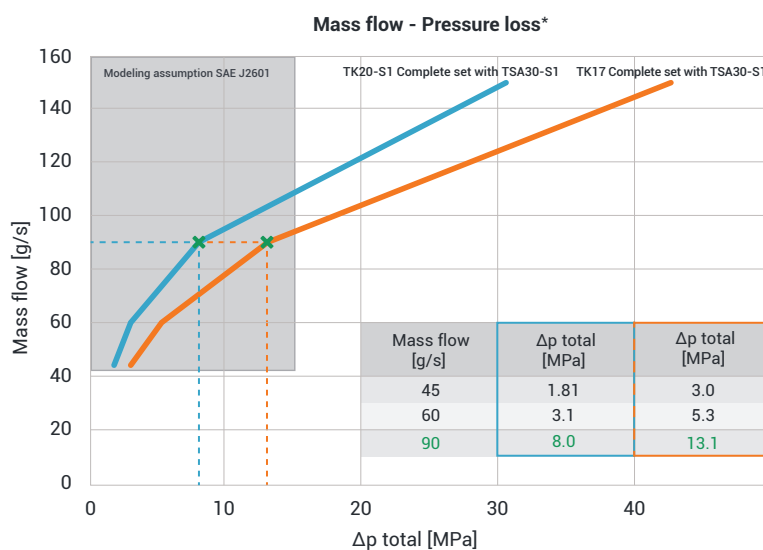

*Values may vary depending on the test setup (e.g. Hose length, receptacle).

Hose set

Hose set for connecting fueling nozzle and TSA30 H₂ 70 MPa breakaway coupling, complete with filling hose, data cable, purging line and braided protection hose as cover.

Design filling hose: max. operating pressure PS: 96.25 MPa / nominal bore fitting (TNW): 4.5 mm / media temperature range: -40°C up to +85°C



Part no.	B1/B2 (female thread)	P1/P2	Hose length
E68-161886	UNF 9/16"-18*	Ø 6/4 mm	3 m
E68-161887	UNF 9/16"-18*	Ø 6/4 mm	4 m
E68-161888	UNF 9/16"-18*	Ø 6/4 mm	5 m

* DKJ 58°

» Fueling nozzle TK20-S1 H₂ 70 MPa ENR

SPARE PARTS TK20-S1 H₂ 70 MPa ENR

Various parts are available as spares for the WEH® TK20-S1 H₂ 70 MPa ENR Fueling nozzle.

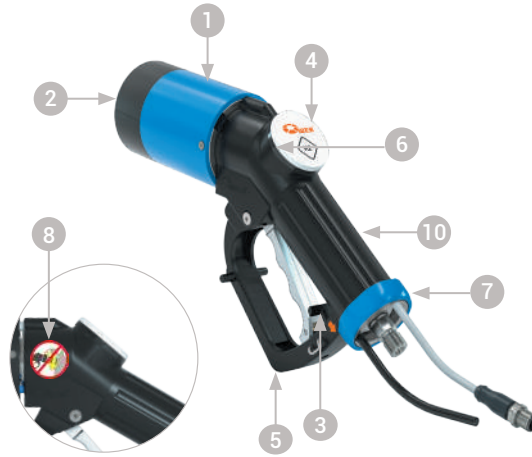

Part No.	Description
W186127	1 Impact protection sleeve
W172310	2 IR data interface ATEX, NEC, KTL or CCC
E80-84030	3 Locking lever
E69-161748	4 Logo cap
W124542	5 Hand grip
E80-59738	6 Logo plate
W186082	Clamping nut for protective hose
E69-157491	7 Label
C1-161187	8 Handle protector
On request	10 Maintenance spray

When ordering please specify the part no. engraved on the fueling nozzle.

ACCESSORIES FOR ALL TK20 VARIANTS

WEH® TNS1 H₂ Service receptacle

To prevent damage in the fueling nozzle while leak testing during maintenance in the course of which pressure is applied, we recommend the use of a service receptacle. The receptacle also protects the fueling nozzle from dirt ingress whilst not in use.



Part no.	Description
C1-148079	TNS1 H ₂ Service receptacle incl. protection cap

WEH® Breakaway coupling

For the suitable TSA30-S1 H₂ 70 MPa breakaway coupling, please see page 26.

Data cable | only for the "ENR" variants

Part no.	Description	Hose length
E68-96194	Data cable suitable for 4 m hose set	4.45 m
E68-96193	Data cable for connecting with the converter	3.45 m

Other lengths on request

» Fueling nozzle TK20-S1 H₂ 70 MPa ENR

Dispenser mounting

The fueling nozzle can also be used with a dispenser mounting, which is installed on the fuel dispenser.

*Advanced dispenser mounting for fueling nozzles
With inductive sensor and M12x1 connector, explosion-proof according to ATEX*

approx. dimensions (mm)

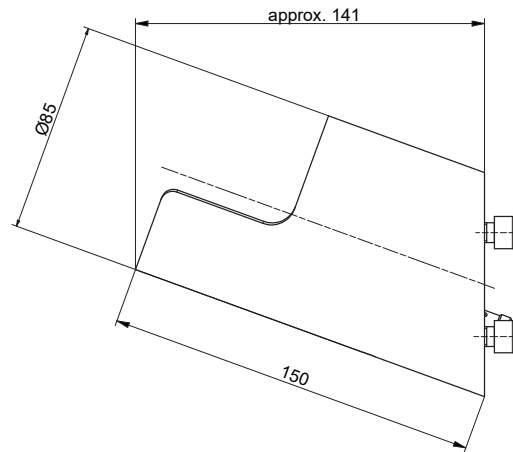

mounting bracket

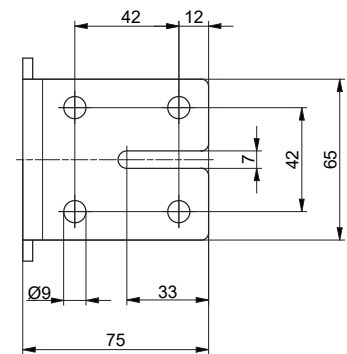

Part no.	Description
C1-190361	Dispenser mounting for TK20 H ₂ (Including mounting bracket, installable in three different designs)

*Classic dispenser mounting for fueling nozzles
With magnetic field sensor and 2 m cable, explosion-proof according to ATEX*

approx. dimensions (mm)

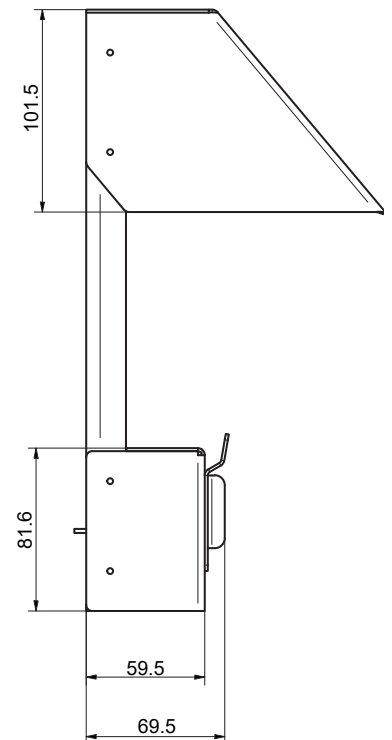
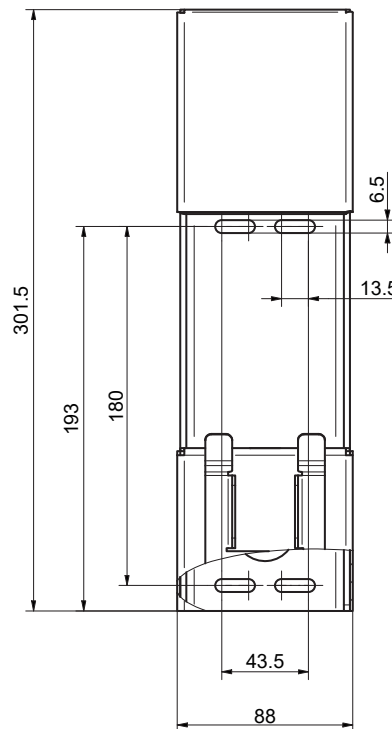

Part No.	Description
C1-191367	Dispenser mounting for TK20 H ₂

» Fueling nozzle TK20-S1 H₂ 70 MPa



DESCRIPTION



Features

- Type C nozzle acc. to SAE J2600 resp. ISO 17268
- Very high flow rate
- Easy operation / single-handed operation
- Max. allowable operating pressure 96.25 MPa (MAWP according to ISO 19880-1:2020)
- Integrated purging line for nitrogen flushing
- WEH® EASY-TURN 250° swivel joint
- Optimized impact protection
- Plastic thermal protection
- Hand grip with magnet
- Compatible with pressure stage H70 according to ISO 17268-1:2025 (see table below)

The WEH® TK20-S1 H₂ 70 MPa Fueling nozzle was developed for fast filling of cars with compressed, gaseous hydrogen (CGH₂). Through to the larger nominal width, refueling with 90 g/s or higher is possible. In addition, this filling nozzle is designed for a maximum operating pressure of 96.25 MPa (= MAWP according to ISO 19880-1:2020).

In addition, the new TK20-S1 H₂ 70 MPa has the same tried and tested features as the already well-known TK17 H₂ 70 MPa.

The fueling nozzle is additionally equipped with a purging line that allows purging with nitrogen during and after refueling process. This can prevent ingress of moisture and the formation of ice crystals during filling with precooled hydrogen.

The WEH® TK20-S1 H₂ 70 MPa offers optimum safety for the operator thanks to the locking mechanism. The Fueling nozzle remains connected to the receptacle until the locking mechanism is released by the operator.

Application

Fueling nozzle for hydrogen fast filling of cars at self-service fueling stations.

		TN H ₂ (Except TN5 H ₂)				
		25 MPa	35 MPa	35 MPa MF*	35 MPa HF**	70 MPa
TK20-S1 H ₂ 70 MPa	70 MPa					✔

*MF = Medium-Flow acc. to ISO 17268-1:2025
**HF = High-Flow acc. to ISO 17268:2012

» Fueling nozzle TK20-S1 H₂ 70 MPa

TECHNICAL DATA

Characteristics	Basic version
Purging line Outer / inner diameter	6/4 mm
Nominal Pressure	PN = 70 MPa
Max. Allowable Operating Pressure	MAWP = 96.25 MPa according to ISO 17268 (PS = 962.5 bar)
Medium*	Hydrogen
Media Temperature Range	-40°C up to +85°C
Ambient Temperature Range	-40°C up to +85°C
Material	Corrosion resistant
Sealing Material	Hydrogen resistant
Nozzle Type	Type C acc. to SAE J2600:2015 and previous resp. ISO 17268:2020 and previous
Coding	H70 Grade D according to ISO 17268-1:2025
Design	With plastic thermal protection Optimized impact protection Integrated purging line Hand grip with magnet
Weight	Approx. 2.65 kg
Medium for Purging	Nitrogen or compressed air
Media Temperature Range Purging Medium	-40°C to +85°C (most effective >0°C)
Hydrogen flow rate	90 g/s at 1.3 MPa pressure drop (F90-P1,3)
Flow Rate During Purging	500 NI/h at max. 12 bar purging pressure
Conformity / Tests / Approvals	Design validation based on ISO 17268-1:2025

* Suitable for pre-cooled hydrogen

» Fueling nozzle TK20-S1 H₂ 70 MPa

ORDERING | WEH® TK20-S1 H₂ 70 MPa Fueling nozzle
 approx. dimensions (mm)

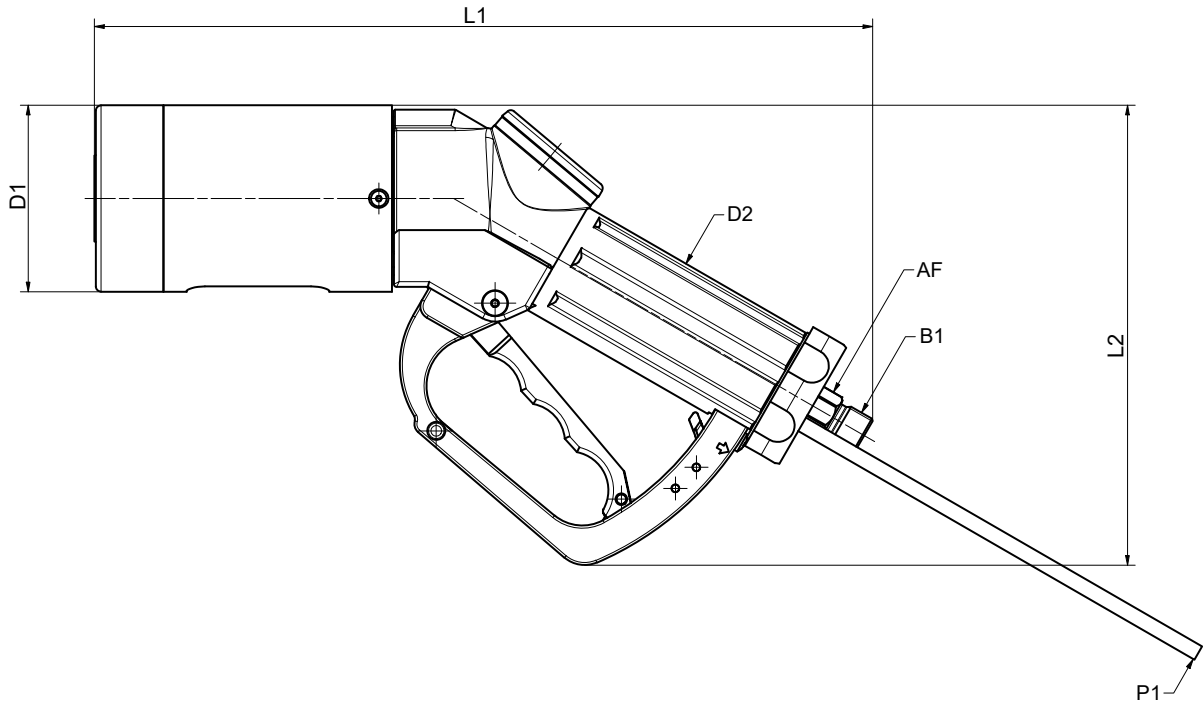

Part no.	Description	Pressure (MAWP)	B1 (male thread)	P1	L1	L2	D1	D2	AF
C1-188782	TK20-S1 H ₂ 70 MPa	96,25 MPa	UNF 9/16"-18*	6/4	300	178	72	46	15

* 60° inner cone

Fueling assemblies consisting of fueling nozzle, hose set and breakaway coupling are available on request.

» Fueling nozzle TK20-S1 H₂ 70 MPa

ACCESSORIES

The following accessories are available for the WEH® TK20-S1 H₂ 70 MPa Fueling nozzle:

Hose set

Hose set for connecting fueling nozzle and TSA30 H₂ 70 MPa breakaway coupling, complete with filling hose, purging line and braided protection hose as cover.

Design filling hose: max. operating pressure PS: 96.25 MPa / nominal bore fitting (TNW): 4.5 mm / media temperature range: -40°C up to +85°C



Part no.	B1/B2 (female thread)	P1/P2	Hose length
C1-189992	UNF 9/16"-18*	Ø 6/4 mm	3 m
C1-189993	UNF 9/16"-18*	Ø 6/4 mm	4 m
C1-189994	UNF 9/16"-18*	Ø 6/4 mm	5 m

* DKJ 58°

For additional accessories such as service receptacle and mountings, see pages 18 and 19.

SPARE PARTS

Various parts are available as spares for the WEH® TK20-S1 H₂ 70 MPa Fueling nozzle.



Part No.	Description
C1-189534	1 Impact protection sleeve (incl. screws)
C1-189537	2 Hand grip (incl. locking lever, clamp and screws)
C1_161748	3 Logo cap
C1-59738	4 Logo plate
C1-186082	5 Clamping nut for protective hose
C1-157491	6 Label
C1-189538	7 Handle protector (incl. screws)
On request	Maintenance spray

When ordering please specify the part no. engraved on the fueling nozzle.

» Breakaway coupling TSA30-S1 H₂ 70 MPa



DESCRIPTION

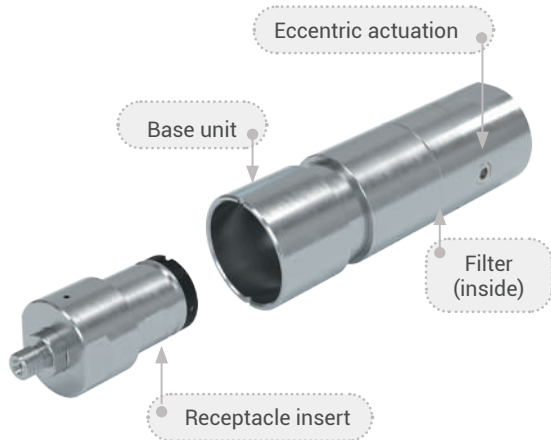

Features

- Enhanced safety → operating pressure up to max. 96.25 MPa
- Integrated filter (5 μm) → for clean filtered hydrogen
- Short and compact design
- Enhanced breakaway force acc. to ISO 19880-3
- Base unit can be reused after breakaway → no factory servicing necessary
- Receptacle insert available as a spare part → no downtime after a breakaway
- Easy installation directly on the dispenser

More safety at hydrogen fueling stations with the new WEH® TSA30-S1 H₂ 70 MPa Breakaway coupling.

The breakaway coupling is installed directly on the dispenser. In the event of unexpected tensile forces, such as a vehicle driving away with a connected fueling nozzle, the TSA30-S1 H₂ 70 MPa separates the connection between the dispenser and hose in a controlled manner. Both sides are sealed pressure-tight directly after breakaway and therefore damage to the vehicle and the dispenser can be prevented as far as possible.

The max. operating pressure of 96.25 MPa offers even more safety. If there is a malfunction, the safety valve of the dispenser opens at a pressure of 96.25 MPa. This high pressure can also reach the breakaway coupling, but the TSA30-S1 H₂ 70 MPa can withstand this pressure perfectly.

In the event of a breakaway, the base unit can be reused - no factory servicing is necessary. Only the receptacle insert needs to be replaced or serviced. Therefore we offer a replacement receptacle insert, to avoid downtime at the dispenser.

The WEH® Breakaway coupling consists of a base unit and a receptacle insert. The integrated filter ensures clean filtered hydrogen and thus prevents damage caused by dirt ingress.

The TSA30-S1 H₂ 70 MPa is suitable for use with pre-cooled hydrogen.

Application

Breakaway coupling for hydrogen fueling stations for direct installation at the dispenser.

TECHNICAL DATA

Characteristics	Basic version
Nominal Pressure	PN = 70 MPa
Max. allowable operating Pressure	MAWP = 96.25 MPa according to ISO 19880-1 (PS = 962.5 bar)
Media temperature range	-40°C up to +85°C
Ambient temperature range	-40°C up to +85°C
Breakaway force	220 - 1,000 N
Material	Corrosion resistant stainless steel
Sealing material	Hydrogen resistant
Design	With filter (5 μm)
Conformity / Tests / Approvals	Design validation based on ISO 19880-3

Other designs on request

» Breakaway coupling TSA30-S1 H₂ 70 MPa

ORDERING | WEH® TSA30-S1 H₂ 70 MPa Breakaway coupling

approx. dimensions (mm)

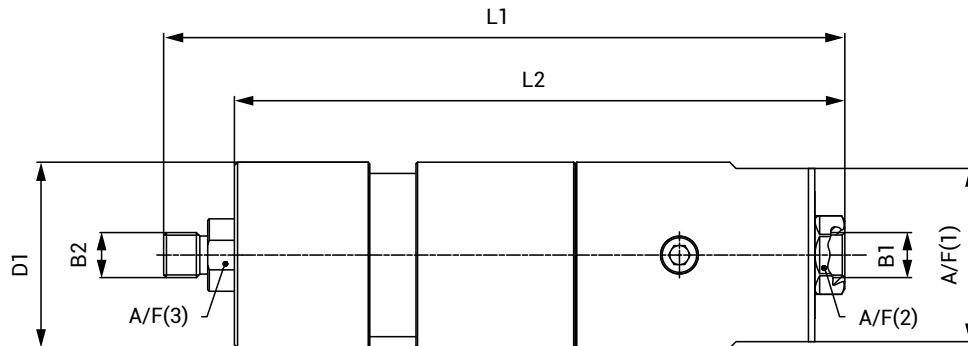

Part No.	Description	TNW	Pressure (MAWP)	B1 (female thread)	B2 (male thread)	L1	L2	D1	A/F(1)	A/F(2)	A/F(3)
C1-163690	TSA30-S1 H ₂ 70 MPa	3.5 mm	96.25 MPa	UNF 9/16"-18*	UNF 9/16"-18**	216	194	59	55	22	21

* MP-fitting, 60° inner cone

** 60° inner cone

» Breakaway coupling TSA30-S1 H₂ 70 MPa

ACCESSORIES

The following accessories are available for the WEH[®] TSA30-S1 H₂ 70 MPa Breakaway coupling:

Dispenser mounting

Mounting for safe attachment of the breakaway coupling to the dispenser. An integrated guide ring in the mounting ensures a straight breakaway force.

approx. dimensions (mm)

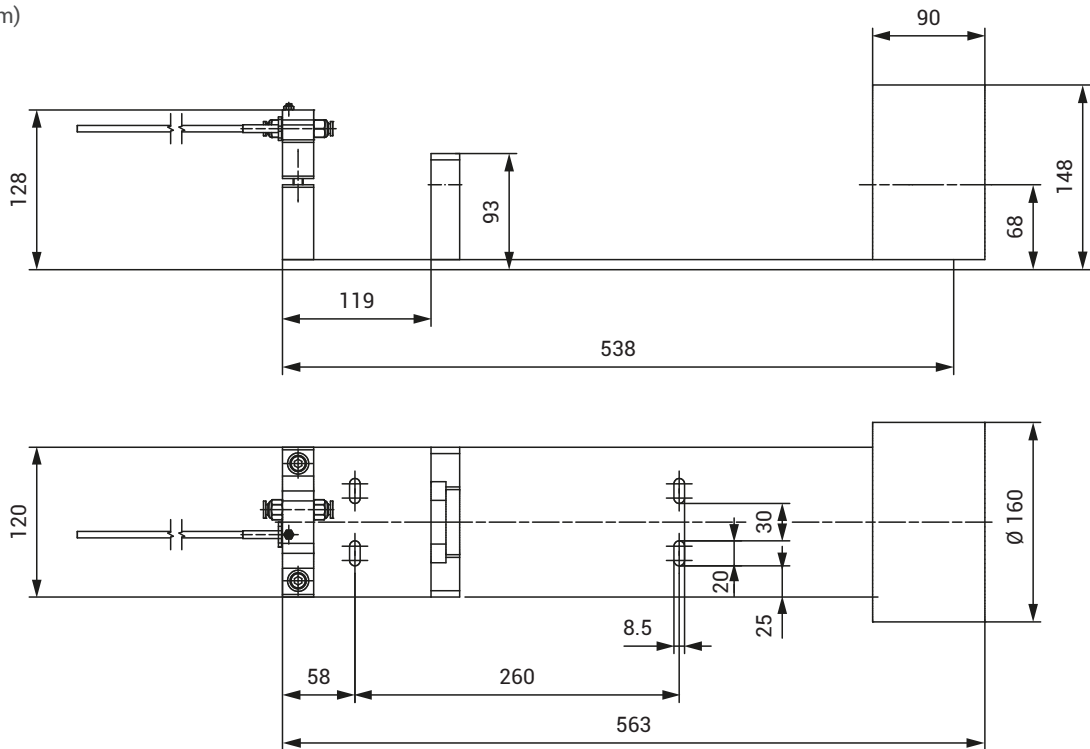

Part no.	Description
C1-183156	Dispenser mounting for TSA30-S1 H ₂ 70 MPa incl. data cable

Hoses

Suitable hoses for the TSA30-S1 H₂ 70 MPa breakaway coupling are available on request.

» Breakaway coupling TSA30-S1 H₂ 70 MPa

SPARE PARTS

Various parts are available as spares for the WEH® TSA30-S1 H₂ 70 MPa Breakaway coupling.

Part No.	Description
C1-168931	Receptacle insert for TSA30-S1 H ₂ 70 MPa

» Breakaway coupling TSA31-S1 H₂ 70 MPa



BESCHREIBUNG

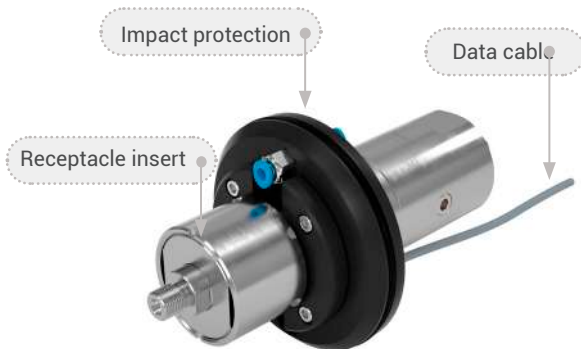

Features

- **Higher safety** → operating pressure up to max. 96.25 MPa
- Integrated filter (5 µm)
 - for clean filtered hydrogen
- Short and compact design
- **Increased breakaway force** in accordance with ISO 19880-3
- Base unit can be reused after demolition
 - no factory servicing necessary
- Receptacle insert available as a spare part
 - no downtime after a tear-off
- **Easy assembly** within the hose set guarantees axial force transmission without additional support

More safety at hydrogen fueling stations with the new WEH® TSA31-S1 H₂ 70 MPa breakaway coupling.

The breakaway coupling is installed directly between the filling hose to the fueling nozzle and the filling hose to the filling station. If unexpected tensile forces occur, e.g. when a vehicle with a connected fueling nozzle drives away, the TSA31-S1 H₂ 70 MPa disconnects the connection between the dispenser and hose in a controlled manner. Both sides are sealed pressure-tight directly after breakaway and therefore damage to the vehicle and the dispenser can be prevented as far as possible.

The max. operating pressure of 96.25 MPa offers even more safety. If there is a malfunction, the safety valve of the dispenser opens at a pressure of 96.25 MPa. This high pressure can also reach the breakaway coupling, but the TSA31-S1 H₂ 70 MPa can withstand this pressure perfectly.

In the event of a breakaway, the base unit can be reused - no factory servicing is necessary. Only the receptacle insert needs to be replaced or serviced. Therefore we offer a replacement receptacle insert, to avoid downtime at the dispenser.

The WEH® breakaway coupling consists of the base unit, the receptacle insert and a holding flange, which contains the plug-in couplings for the data cable and purging cable. The integrated filter ensures clean filtered hydrogen and thus prevents damage caused by dirt ingress. The TSA31-S1 H₂ 70 MPa is suitable for use with pre-cooled hydrogen.

Application

Breakaway coupling for hydrogen filling stations for installation between two filling hoses.

» Breakaway coupling TSA31-S1 H, 70 MPa

TECHNICAL DATA

Characteristics	Basic version
Nominal Pressure	PN = 70 MPa
Max. allowable operating Pressure	MAWP = 96.25 MPa according to ISO 19880-1 (PS = 962.5 bar)
Media temperature range	-40°C up to +85°C
Ambient temperature range	-40°C up to +85°C
Breakaway force	220 - 1,000 N
Material	Wear-resistant stainless steel, corrosion-resistant surfaces
Sealing material	Hydrogen resistant
Design	With integrated filter (5 µm)
Conformity / Tests / Approvals	Design validation based on ISO 19880-3

Other designs on request

» Breakaway coupling TSA31-S1 H₂ 70 MPa

ORDERING | WEH® TSA31-S1 H₂ 70 MPa breakaway coupling

approx. dimensions (mm)

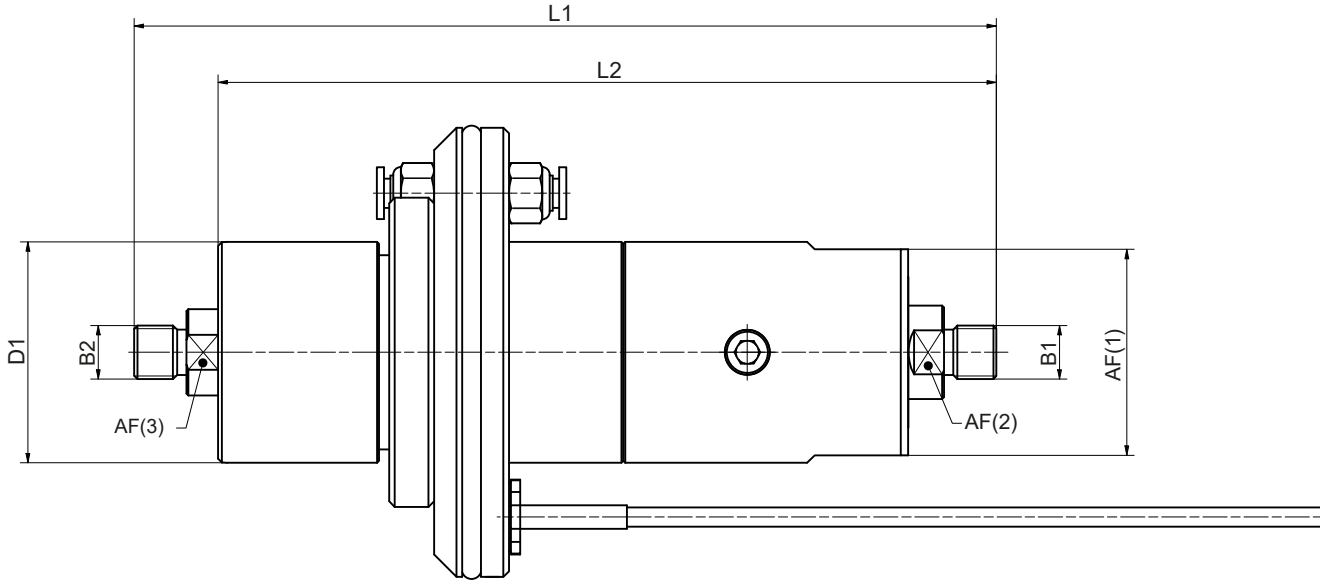

Part No.	Description	DN	Pressure (MAWP)	B1 (male thread)	B2 (male thread)	L1	L2	D1	D2	AF (1)	AF (2)	AF (3)
C1-188029	TSA31-S1 H ₂ 70 MPa	3.5 mm	96.25 MPa	UNF 9/16"-18*	UNF 9/16"-18*	320	207	59	120	55	22	21

* 60° inner cone, type M

» Breakaway coupling TSA31-S1 H₂ 70 MPa

ACCESSORIES

The following accessories are available for the WEH® TSA31-S1 H₂ 70 MPa breakaway coupling:

Hose set between dispenser and breakaway coupling:

Part No.	Description	Hose length
C1-112185	Pressure hose H ₂ 70 MPa	0.5 m

Hose set from the breakaway coupling to the fueling nozzle:

Part No.	Description	Hose length
C1-167804	Hose set H ₂ 70 MPa	2.5 m
C1-189699	Hose set H ₂ 70 MPa	3.5 m
C1-189702	Hose set H ₂ 70 MPa	4.5 m

SPARE PARTS

Various parts are available as spares for the WEH® TSA31-S1 H₂ 70 MPa breakaway coupling.

Part No.	Description
C1-168931	Receptacle insert for TSA31-S1 H ₂ 70 MPa

» Receptacle TN9-S1 H₂ 70 MPa



DESCRIPTION



Features

- High flow rate of up to 90 g/s for fast refueling
- 10- μ m metal wire mesh filter, customizable
- Tested according to ISO 17268:2020 for maximum safety
- Low-noise refueling thanks to optimized inner shape
- Seal-friendly design: Robust, durable and easy to maintain
- Coding for pressure range / gas type (acc. to table below)

The WEH® TN9-S1 H₂ 70 MPa receptacle was specially developed for refueling vehicles with hydrogen in the 700 bar pressure range.

The aerodynamically optimized inner shape of the receptacle ensures a virtually silent filling process and guarantees a maximum flow rate of up to 90 g/s. The seal-friendly design effectively protects internal seals from damage and ensures a long service life.

Thanks to its robustness and minimal maintenance requirements, the TN9-S1 H₂ 70 MPa is particularly reliable and helps to reduce downtimes. It is also equipped with an integrated check valve and offers maximum safety and compatibility in accordance with ISO 17268:2020.

More safety thanks to integrated self-cleaning particle filter

The integrated filter cartridge with a pore size of 10 μ m, custom-made for the TN9, offers reliable protection against dirt particles and impurities. Its multi-layer wire mesh enables outstanding filter performance by effectively removing even long fibers and the smallest particles. This filter not only prevents leaks at the receptacle, but also ensures that operation remains safe and reliable even under difficult environmental conditions. The filter can also be flexibly adapted to different degrees of purity to meet your specific requirements.

		TK H ₂ (Except TK25 H ₂)				
		25 MPa	35 MPa	35 MPa MF*	35 MPa HF**	70 MPa
TN9-S1 H ₂ 70 MPa	70 MPa	✓	✓			✓

*MF = Medium-Flow acc. to ISO 17268-1:2025
**HF = High-Flow acc. to ISO 17268:2012

Application

Receptacle for hydrogen refueling / filling of trucks, buses, vans, cars and for industrial applications suitable for the WEH® fueling nozzle according to the table below.

TECHNICAL DATA

Characteristics	Basic version
Technical nominal size (TNW)	4 mm
Nominal pressure	PN = 70 MPa
Max. allowable operating pressure	MOP = 87.5 MPa (PS = 875 bar)
Temperature range	-40°C up to +85°C
Material	Corrosion resistant
Sealing material	Hydrogen resistant
Design	With protection cap, integrated particle filter and integrated check valve
Coding	H70 Grade D according to ISO 17268-1:2025
Conformity / Tests / Approvals	Tested according to ISO 17268:2020

Other designs on request

» Receptacle TN9-S1 H₂ 70 MPa

ORDERING | WEH® TN9-S1 H₂ 70 MPa Receptacle with male thread

approx. dimensions (mm)

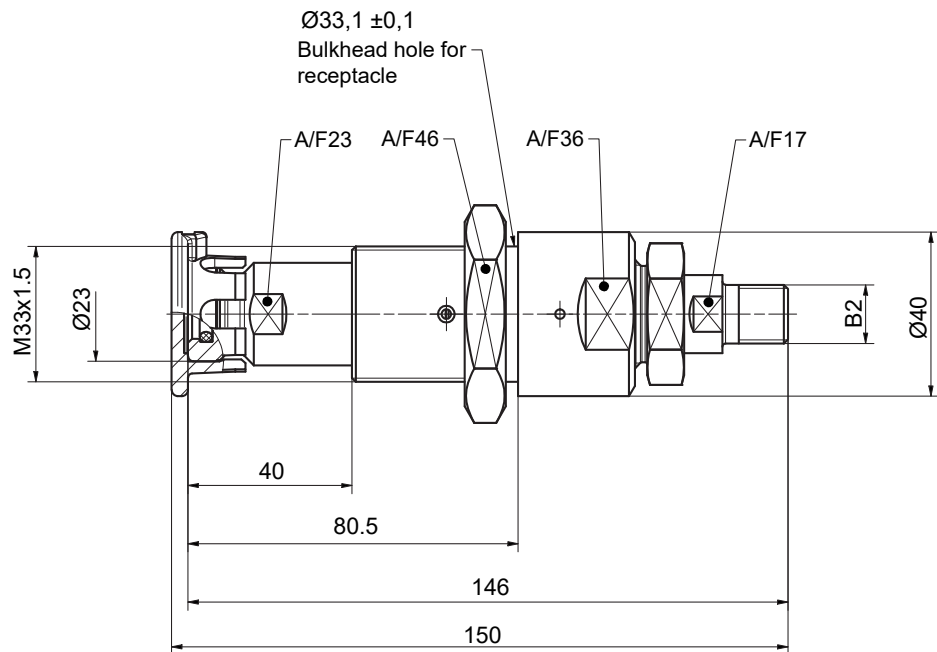

Part No.	Description	Mesh size filter	Pressure (MOP)	B2 (male thread)
C1-185258	TN9-S1 H ₂ 70 MPa	10 µm	87.5 MPa	UNF 9/16"-18*

*Connection geometry: MP fitting, 60° internal cone

ORDERING | WEH® TN9-S1 H₂ 70 MPa Receptacle with female thread

approx. dimensions (mm)

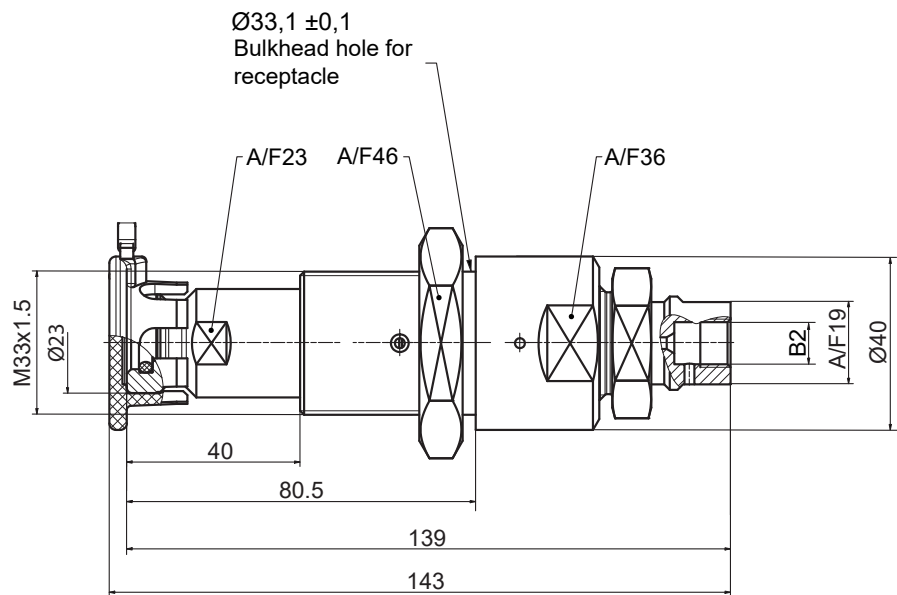

Part No.	Description	Mesh size filter	Pressure (MOP)	B2 (female thread)
C1-188769	TN9-S1 H ₂ 70 MPa	10 µm	87.5 MPa	UNF 7/16"-20*

*Connection geometry: MP fitting, 60° internal cone

» Receptacle TN9-S1 H₂ 70 MPa

OERDERING | WEH® TN9-S1 H₂ 70 MPa Receptacle with male thread

approx. dimensions (mm)

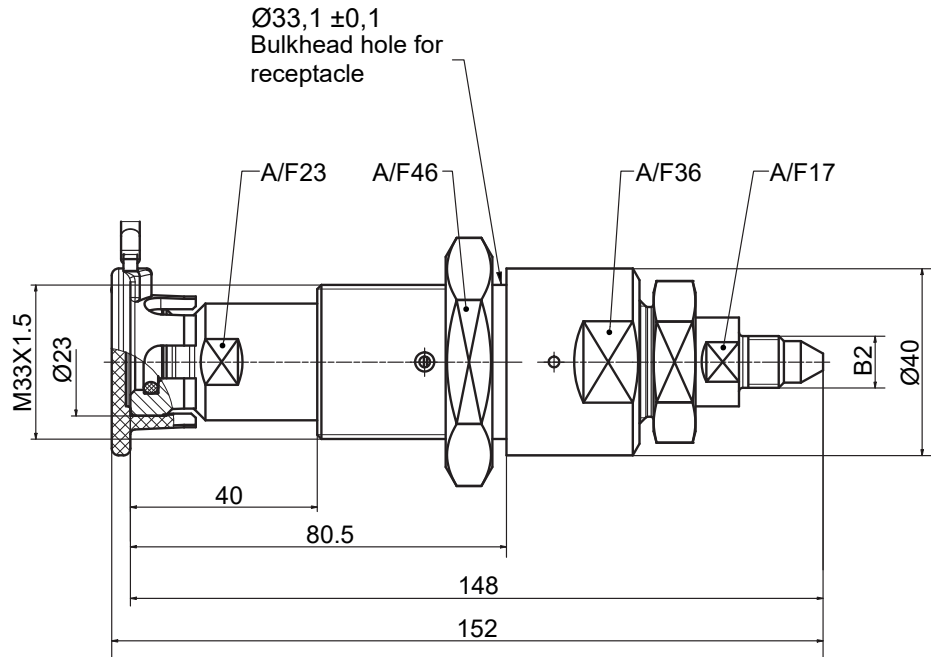

Part No.	Description	Mesh size filter	Pressure (MOP)	B2 (male thread)
C1-188771	TN9-S1 H ₂ 70 MPa	10 µm	87.5 MPa	UNF 7/16"-20*

*Connection geometry: MP fitting, 59° internal cone

Other connections (e.g. O-Lok Face Seal or VOSSLok⁴⁰ or ISO 18418) on request.

» Receptacle TN9-S1 H₂ 70 MPa

ACCESSORIES

The following accessories are available for the WEH® TN9-S1 H₂ 70 MPa Receptacle:

Infrared data interface incl. holder for TN9

Application example:

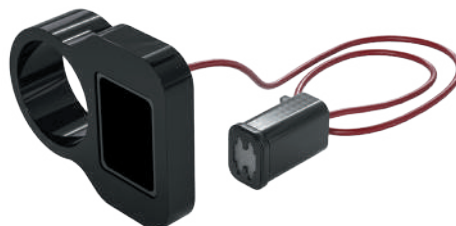

Part No.	Description
C1-188500	Infrared data interface incl. holder for TN9 (Input signal RS485, output signal J2799 Infrared)
C1-188941	Mounting nut (for IR interface)

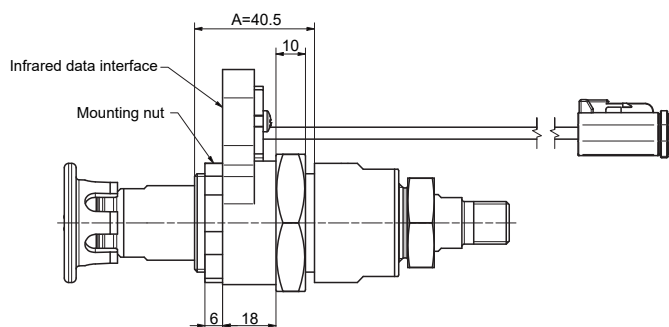

Note: The WEH® receptacle is designed to accommodate an attached data interface in area "A."
When installing the WEH® receptacle, ensure that the permissible installation space A of 40.5 mm is not exceeded.

Take into account the sheet thickness, nut height, and data interface, including the mounting element.

When using data interface C1-188500 and mounting nut C1-188941, the sheet metal thickness must not exceed 6 mm.

SPARE PARTS

Various parts are available as spares for the WEH® TN9-S1 H₂ 70 MPa Receptacle.

Protection cap / Nut

Protection cap with a strap to protect the receptacle from dirt ingress.



Part No.	Description
W85984	Protection cap for receptacles
C1-185122	TN9-H70 Nut M33x1.5 for receptacle mounting

» Check valve TVR9 H₂ 70 MPa



DESCRIPTION



Features

- **Quiet** opening and closing
- **High flow rate** of up to 90 g/s for fast refueling
- Available with or without filter
- **Sealing-friendly design:** Robust, durable, and easy to maintain

With the TVR9 H₂ 70 MPa WEH offers a high-performance check valve for use in hydrogen road vehicles or hydrogen fueling stations of the latest generation.

The WEH[®] TVR9 H₂ 70 MPa check valves provide a reliable function wherever hydrogen should only flow in one direction within a pipe system and must be prevented from a return flow.

The sealings in the valve are arranged to prevent them from being damaged by dirt particles in the gas flow.

The WEH[®] TVR9 H₂ 70 MPa Check valve is made of corrosion-resistant stainless steel achieving a very durable unit due to its robust internal structure.

Application

Check valve for road vehicles, also suitable for installation in hydrogen fueling stations.

The WEH[®] TVR9 H₂ 70 MPa product family is offered as a return flow prevention acc. to DIN EN 736-1 for installation in H₂ systems and pipelines.

TECHNICAL DATA

Characteristics	Basic version
Technical nominal size (TNW)	Depending on design
Nominal Pressure	PN = 70 MPa
Max. allowable operating Pressure	MAWP = 87.5 MPa according to ISO 17168 (PS = 875 bar)
Temperature range	-40°C up to +85°C
Material	Corrosion resistant
Sealing material	Hydrogen resistant
Design	With or without integrated particle filter (10 µm)
Conformity / Tests / Approvals	Based on TN9 H ₂ 70 MPa developed in accordance with ISO 17268:2020

Other designs on request

» Check valve TVR9 H₂ 70 MPa

ORDERING | WEH® TVR9 H₂ 70 MPa check valve with external thread on both sides and filter (10 µm)

approx. dimensions (mm)

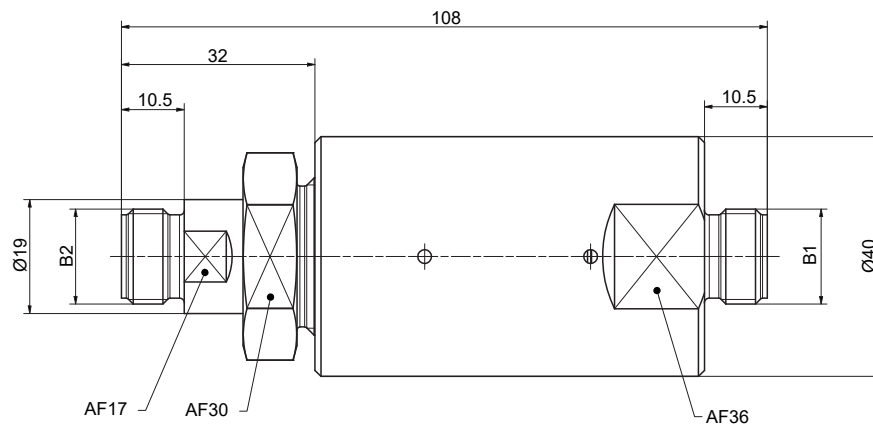

Part no.	Description	Filter	TNW	Pressure MAWP	B1 (male thread)	B2 (male thread)
On request	TVR9 H ₂ 70 MPa	10 µm	4 mm	87.5 MPa	UNF 7/16"-20*	UNF 7/16"-20*

* MP-Fitting, 60° inner cone

Other connection sizes and types (e.g. Face seal according to SAE J1453 or VOSSLok⁴⁰) on request.

» Check valve TVR1 H₂ 70 MPa

DESCRIPTION



Features

- Robust construction
- Low-noise opening and closing
- Corrosion resistant stainless steel
- High leak tightness

With the TVR1 H₂ 70 MPa WEH offers a high-performance check valve for use in hydrogen cars or hydrogen fueling stations of the latest generation.

The WEH[®] TVR1 H₂ 70 MPa check valves provide a reliable function wherever hydrogen should only flow in one direction within a pipe system and must be prevented from a return flow.

The seals in the valve are arranged to prevent them from being damaged by dirt particles in the gas flow. The WEH[®] TVR1 H₂ 70 MPa Check valve is made of corrosion-resistant stainless steel achieving a very durable unit due to its robust internal structure.

Application

Check valve for cars, also suitable for installation in hydrogen fueling stations.

The WEH[®] TVR1 H₂ 70 MPa product family is offered as a return flow prevention acc. to DIN EN 736-1 for installation in H₂ systems and pipelines.

TECHNICAL DATA

Characteristics	Basic version
Technical nominal size (TNW)	Depending on design
Nominal Pressure	PN = 70 MPa
Max. allowable operating Pressure	MAWP = 87.5 MPa according to ISO 17168 (PS = 875 bar)
Temperature range	-40°C up to +85°C
Material	Corrosion resistant stainless steel
Sealing material	Hydrogen resistant
Design	With or without integrated particle filter (20 µm)
Conformity / Tests / Approvals	 00 0009 (Regulation (EC) No. 79/2009)

Other designs on request

» Check valve TVR1 H₂ 70 MPa

ORDERING | WEH® TVR1 H₂ 70 MPa Check valve with male thread on both sides (Face Seal on both sides)
approx. dimensions (mm)

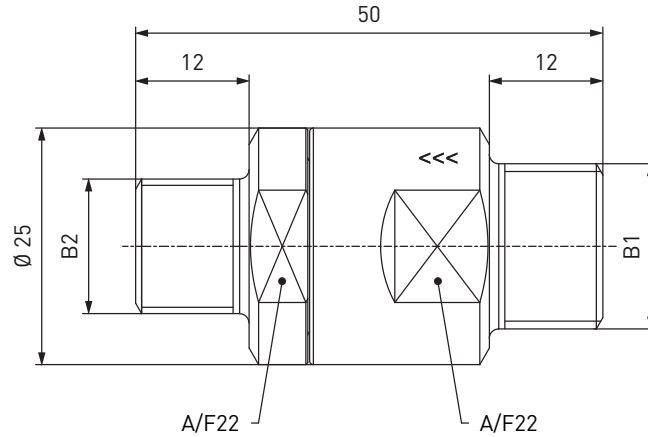

Part No.	Description	TNW	Pressure (MAWP)	B1 (male thread)	B2 (male thread)
C1-76959-X1	TVR1 H ₂ 70 MPa (EC79)	4 mm	87.5 MPa	UN 11/16"-16 for sealing with O-Lok® Face Seal* for tube Ø 10 (3/8")	UNF 9/16"-18 for sealing with O-Lok® Face Seal* for tube Ø 6 (1/4")

* Face Seal acc. to SAE J1453

ORDERING | WEH® TVR1 H₂ 70 MPa Check valve with female thread / male thread and filter (20 µm)
approx. dimensions (mm)

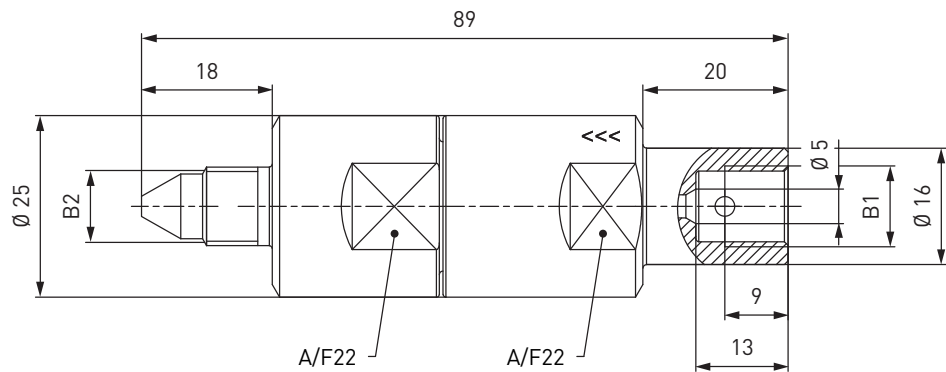

Part No.	Description	TNW	Pressure (MAWP)	B1 (female thread)	B2 (male thread)
C1-87743	TVR1 H ₂ 70 MPa (EC79)	2.5 mm	87.5 MPa	UNF 7/16"-20*	UNF 7/16"-20**

* MP-fitting, 60° inner cone

** MP-fitting, 59° outer cone

Other connection sizes and types (e.g. Cone and Thread Fittings or VOSSLok⁴⁰) on request.

» Fueling nozzle TK20-S2 H₂ 35 MPa ENR



DESCRIPTION



Features

- Type C nozzle acc. to SAE J2600 resp. ISO 17268
- Very high flow rate
- Easy operation / single-handed operation
- Max. allowable operating pressure 48.125 MPa (MAWP according to ISO 19880-1:2020)
- Exchangeable data interface (ENR)
- Integrated purging line for nitrogen flushing
- WEH® EASY-TURN 250° swivel joint
- Optimized impact protection to protect the data interface
- Plastic thermal protection
- Hand grip with magnet
- Compatible with pressure stage H35 according to ISO 17268-1:2025 (see table below)

The WEH® TK20-S2 H₂ 35 MPa ENR Fueling nozzle with exchangeable data interface (ENR = exchangeable nozzle receiver) was developed for fast filling of cars with compressed, gaseous hydrogen (CGH₂). Through to the larger nominal width, refueling with 90 g/s or higher is possible. In addition, this filling nozzle is designed for a maximum operating pressure of 48.125 MPa (= MAWP according to ISO 19880-1:2020).

In addition, the new TK20-S2 H₂ 35 MPa ENR has the same tried and tested features as the already well-known TK17 H₂ 70 MPa ENR.

The fueling nozzle is additionally equipped with a purging line that allows purging with nitrogen during and after refueling process. This can prevent ingress of moisture and the formation of ice crystals during filling with precooled hydrogen.

The WEH® TK20-S2 H₂ 35 MPa ENR offers optimum safety for the operator thanks to the locking mechanism. The Fueling nozzle remains connected to the receptacle until the locking mechanism is released by the operator.

Application

Fueling nozzle for hydrogen fast filling of cars at self-service fueling stations.

		TN H ₂ (Except TN5 H ₂)				
		25 MPa	35 MPa	35 MPa MF*	35 MPa HF**	70 MPa
TK20-S2 H ₂ 35 MPa ENR	35 MPa		✓	✓	✓	✓
	35 MPa					

*MF = Medium-Flow acc. to ISO 17268-1:2025
**HF = High-Flow acc. to ISO 17268:2012

» Fueling nozzle TK20-S2 H₂ 35 MPa ENR

TECHNICAL DATA

Characteristics	Basic version
Purging line Outer / inner diameter	6/4 mm
Nominal Pressure	PN = 35 MPa
Max. Allowable Operating Pressure	MAWP = 48.125 MPa according to ISO 17268 (PS = 481.25 bar)
Medium*	Hydrogen
Media Temperature Range	-40°C up to +85°C
Ambient Temperature Range	-40°C up to +85°C
Material	Corrosion resistant
Sealing Material	Hydrogen resistant
Nozzle Type	Type C acc. to SAE J2600:2015 and previous resp. ISO 17268:2020 and previous
Coding	H35 according to ISO 17268-1:2025
Design	With plastic thermal protection Optimized impact protection to protect the data interface Exchangeable data interface acc. to SAE J2799 Integrated purging line Hand grip with magnet
Weight	Approx. 2.65 kg
Medium for Purging	Nitrogen or compressed air
Media Temperature Range Purging Medium	-40°C to +85°C (most effective >0°C)
Flow Rate During Purging	500 NI/h at max. 12 bar purging pressure
Conformity / Tests / Approvals	IR data interface: SAE J2799 and ATEX, NEC, KTL, CCC Design validation based on ISO 17268-1:2025

* Suitable for pre-cooled hydrogen

» Fueling nozzle TK20-S2 H₂ 35 MPa ENR

ORDERING | WEH® TK20-S2 H₂ 35 MPa ENR Fueling nozzle

approx. dimensions (mm)

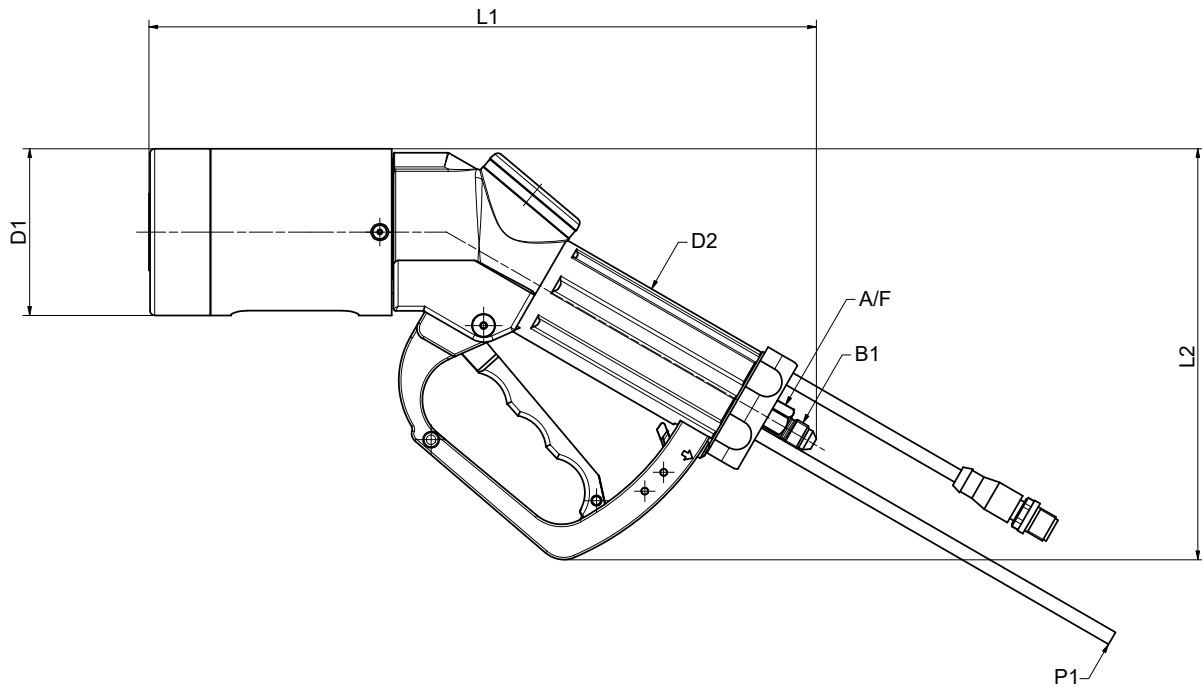

Part no.	Description	Pressure (MAWP)	B1 (male thread)	P1	L1	L2	D1	D2	A/F
C1-188780	TK20-S2 H ₂ 35 MPa ENR	48.125 MPa	UNF 7/16"-20*	6/4	289	178	72	46	15

* according to SAE J514 with 37° outer cone

Fueling assemblies consisting of fueling nozzle, hose set and breakaway coupling are available on request.

» Fueling nozzle TK20-S2 H₂ 35 MPa ENR

ACCESSORIES

The following accessories are available for the WEH® TK20-S2 H₂ 35 MPa ENR Fueling nozzle:

Hose set

Hose set for connecting fueling nozzle and TSA1 H₂ breakaway coupling, complete with filling hose, data cable, purging line and braided protection hose as cover.

Design filling hose: max. operating pressure PS: 49 MPa / nominal bore fitting (TNW): 4.5 mm / media temperature range: -40°C up to +85°C

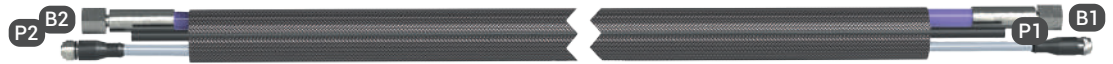

Part no.	B1/B2 (female thread)	P1/P2	Hose length
E68-174299	UNF 7/16"-20*	Ø 6/4 mm	3 m
E68-174300	UNF 7/16"-20*	Ø 6/4 mm	4 m
E68-174301	UNF 7/16"-20*	Ø 6/4 mm	5 m

* according to SAE JIC, 37° sealing cone

For additional accessories such as service receptacle and mountings, see pages 18 and 19.

SPARE PARTS

Various parts are available as spares for the WEH® TK20-S2 H₂ 35 MPa ENR Fueling nozzle.

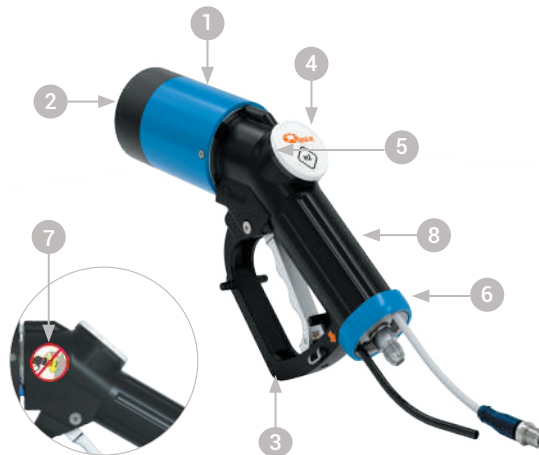

Part No.	Description
C1-189533	1 Impact protection sleeve (incl. screws)
C1-189535	2 IR data interface ATEX, NEC, KTL, CCC (incl. O-ring and screws)
C1-189537	3 Hand grip (incl. locking lever, clamp and screws)
C1-161748	4 Logo cap
C1-59738	5 Logo plate
C1-186082	6 Clamping nut for protective hose
C1-157491	7 Label
C1-189538	8 Handle protector (incl. screws)
On request	Maintenance spray

When ordering please specify the part no. engraved on the fueling nozzle.

» Fueling Nozzle TK20-S2 H₂ 35 MPa



DESCRIPTION



Features

- Type C nozzle acc. to SAE J2600 resp. ISO 17268
- Very high flow rate
- Easy operation / single-handed operation
- Max. allowable operating pressure 48.125 MPa (MAWP according to ISO 19880-1:2020)
- Integrated purging line for nitrogen flushing
- WEH® EASY-TURN 250° swivel joint
- Optimized impact protection Plastic thermal protection
- Hand grip with magnet
- Compatible with pressure stage H35 according to ISO 17268-1:2025 (see table below)

The WEH® TK20-S2 H₂ 35 MPa Fueling nozzle was developed for fast filling of cars with compressed, gaseous hydrogen (CGH₂). Through to the larger nominal width, refueling with 90 g/s or higher is possible. In addition, this filling nozzle is designed for a maximum operating pressure of 48.125 MPa (= MAWP according to ISO 19880-1:2020).

In addition, the new TK20-S2 H₂ 35 MPa has the same tried and tested features as the already well-known TK17 H₂ 70 MPa.

The fueling nozzle is additionally equipped with a purging line that allows purging with nitrogen during and after refueling process. This can prevent ingress of moisture and the formation of ice crystals during filling with precooled hydrogen.

The WEH® TK20-S2 H₂ 35 MPa offers optimum safety for the operator thanks to the locking mechanism. The Fueling nozzle remains connected to the receptacle until the locking mechanism is released by the operator.

Application

Fueling nozzle for hydrogen fast filling of cars at self-service fueling stations.

		TN H ₂ (Except TN5 H ₂)				
		25 MPa	35 MPa	35 MPa MF*	35 MPa HF**	70 MPa
TK20-S2 H ₂ 35 MPa	35 MPa		✓	✓	✓	✓
	35 MPa					

*MF = Medium-Flow acc. to ISO 17268-1:2025
**HF = High-Flow acc. to ISO 17268:2012

» Fueling nozzle TK20-S2 H₂ 35 MPa

TECHNICAL DATA

Characteristics	Basic version
Purging line Outer / inner diameter	6/4 mm
Nominal Pressure	PN = 35 MPa
Max. Allowable Operating Pressure	MAWP = 48.125 MPa according to ISO 17268 (PS = 481.25 bar)
Medium*	Hydrogen
Media Temperature Range	-40°C up to +85°C
Ambient Temperature Range	-40°C up to +85°C
Material	Corrosion resistant
Sealing Material	Hydrogen resistant
Nozzle Type	Type C acc. to SAE J2600:2015 and previous resp. ISO 17268:2020 and previous
Coding	H35 according to ISO 17268-1:2025
Design	With plastic thermal protection Optimized impact protection Integrated purging line Hand grip with magnet
Weight	Approx. 2.65 kg
Medium for Purging	Nitrogen or compressed air
Media Temperature Range Purging Medium	-40°C to +85°C (most effective >0°C)
Flow Rate During Purging	500 NI/h at max. 12 bar purging pressure
Conformity / Tests / Approvals	Design validation based on ISO 17268-1:2025

* Suitable for pre-cooled hydrogen

» Fueling nozzle TK20-S2 H₂ 35 MPa

ORDERING | WEH® TK20-S2 H₂ 35 MPa Fueling nozzle

approx. dimensions (mm)

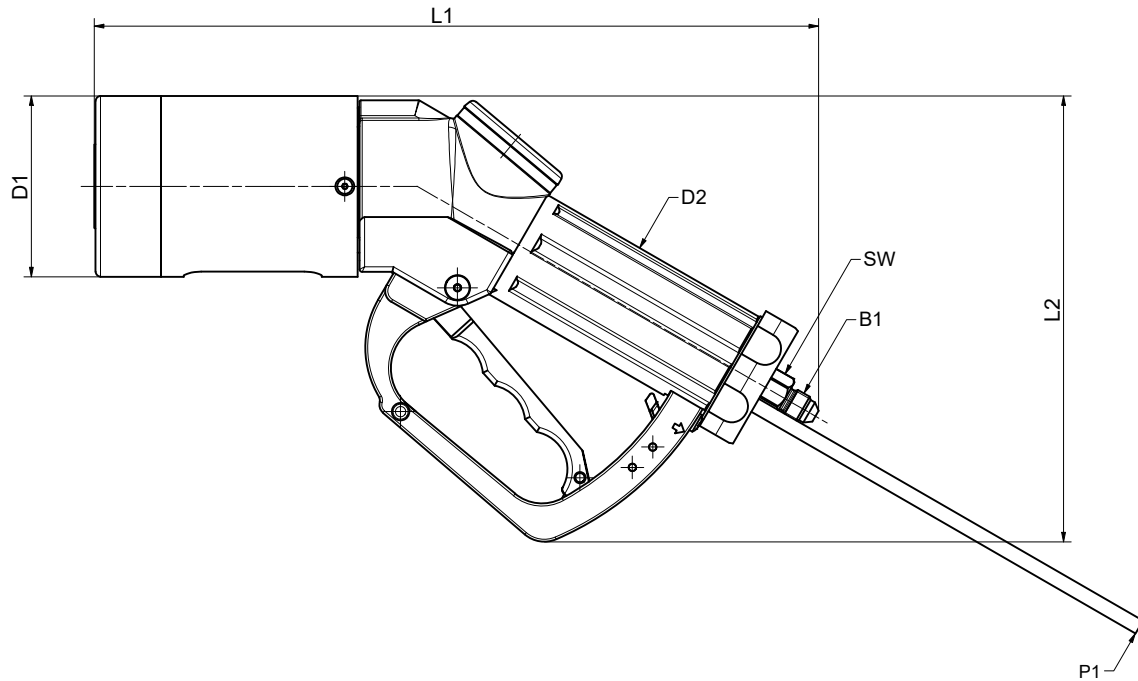

Part no.	Description	Pressure (MAWP)	B1 (male thread)	P1	L1	L2	D1	D2	AF
C1-188783	TK20-S2 H ₂ 35 MPa	48.125 MPa	UNF 7/16"-20*	6/4	289	178	72	46	15

* according to SAE J514 with 37° outer cone

Fueling assemblies consisting of fueling nozzle, hose set and breakaway coupling are available on request.

» Fueling nozzle TK20-S2 H₂ 35 MPa

ACCESSORIES

The following accessories are available for the WEH® TK20-S2 H₂ 35 MPa Fueling nozzle:

Hose set

Hose set for connecting fueling nozzle and TSA1 H₂ breakaway coupling, complete with filling hose, purging line and braided protection hose as cover.

Design filling hose: max. operating pressure PS: 49 MPa / nominal bore fitting (TNW): 4.5 mm / media temperature range: -40°C up to +85°C



Part no.	B1/B2 (female thread)	P1/P2	Hose length
C1-189989	UNF 7/16"-20*	Ø 6/4 mm	3 m
C1-189990	UNF 7/16"-20*	Ø 6/4 mm	4 m
C1-189991	UNF 7/16"-20*	Ø 6/4 mm	5 m

* according to SAE JIC, 37° sealing cone

For additional accessories such as service receptacle and mountings, see pages 18 and 19.

SPARE PARTS

Various parts are available as spares for the WEH® TK20-S2 H₂ 35 MPa Fueling nozzle.



Part No.	Description
C1-189533	1 Impact protection sleeve (incl. screws)
C1-189537	2 Hand grip (incl. locking lever, clamp and screws)
C1-161748	3 Logo cap
C1-59738	4 Logo plate
C1-186082	5 Clamping nut for protective hose
C1-157491	6 Label
C1-189538	7 Handle protector (incl. screws)
On request	Maintenance spray

When ordering please specify the part no. engraved on the fueling nozzle.

» Fueling nozzle TK20-S3 H₂ 35 MPa ENR Medium-Flow



DESCRIPTION



Features

- Type C nozzle acc. to SAE J2600 resp. ISO 17268
- Very high flow rate
- Easy operation / single-handed operation
- Max. allowable operating pressure 48.125 MPa (MAWP according to ISO 19880-1:2020)
- Exchangeable data interface (ENR)
- Integrated purging line for nitrogen flushing
- WEH® EASY-TURN 250° swivel joint
- Optimized impact protection to protect the data interface
- Plastic thermal protection
- Hand grip with magnet
- Compatible with pressure stage H35 Medium-Flow according to ISO 17268-1:2025 (see table below)

The WEH® TK20-S3 H₂ 35 MPa ENR Medium-Flow Fueling nozzle with exchangeable data interface (ENR = exchangeable nozzle receiver) was developed for fast filling of cars with compressed, gaseous hydrogen (CGH₂). Through to the larger nominal width, refueling with 120 g/s or higher is possible. In addition, this filling nozzle is designed for a maximum operating pressure of 48.125 MPa (= MAWP according to ISO 19880-1:2020).

The fueling nozzle is additionally equipped with a purging line that allows purging with nitrogen during and after refueling process. This can prevent ingress of moisture and the formation of ice crystals during filling with precooled hydrogen.

The WEH® TK20-S3 H₂ 35 MPa ENR Medium-Flow offers optimum safety for the operator thanks to the locking mechanism. The Fueling nozzle remains connected to the receptacle until the locking mechanism is released by the operator.

Application

Fueling nozzle for rapid filling of buses and trucks with hydrogen in self-service operation.

		TN H ₂ (Except TN5 H ₂)				
		25 MPa	35 MPa	35 MPa MF*	35 MPa HF**	70 MPa
TK20-S3 H ₂ 35 MPa ENR Medium-Flow	35 MPa			✓	✓	

*MF = Medium-Flow acc. to ISO 17268-1:2025
 **HF = High-Flow acc. to ISO 17268:2012

» Fueling nozzle TK20-S3 H₂ 35 MPa ENR Medium-Flow

TECHNICAL DATA

Characteristics	Basic version
Purging line Outer / inner diameter	6/4 mm
Nominal Pressure	PN = 35 MPa
Max. Allowable Operating Pressure	MAWP = 48.125 MPa according to ISO 17268 (PS = 481.25 bar)
Medium*	Hydrogen
Media Temperature Range	-40°C up to +85°C
Ambient Temperature Range	-40°C up to +85°C
Material	Corrosion resistant
Sealing Material	Hydrogen resistant
Nozzle Type	Type C acc. to SAE J2600:2015 and previous resp. ISO 17268:2020 and previous
Coding	H35MF according to ISO 17268-1:2025
Design	With plastic thermal protection Optimized impact protection to protect the data interface Exchangeable data interface acc. to SAE J2799 Integrated purging line Hand grip with magnet
Weight	Approx. 2.65 kg
Medium for Purging	Nitrogen or compressed air
Media Temperature Range Purging Medium	-40°C to +85°C (most effective >0°C)
Flow Rate During Purging	500 NI/h at max. 12 bar purging pressure
Conformity / Tests / Approvals	IR data interface: SAE J2799 and ATEX, NEC, KTL, CCC Design validation based on ISO 17268-1:2025

* Suitable for pre-cooled hydrogen

» Fueling nozzle TK20-S3 H₂ 35 MPa ENR Medium-Flow

ORDERING | WEH® TK20-S3 H₂ 35 MPa ENR Medium-Flow Fueling nozzle
 approx. dimensions (mm)

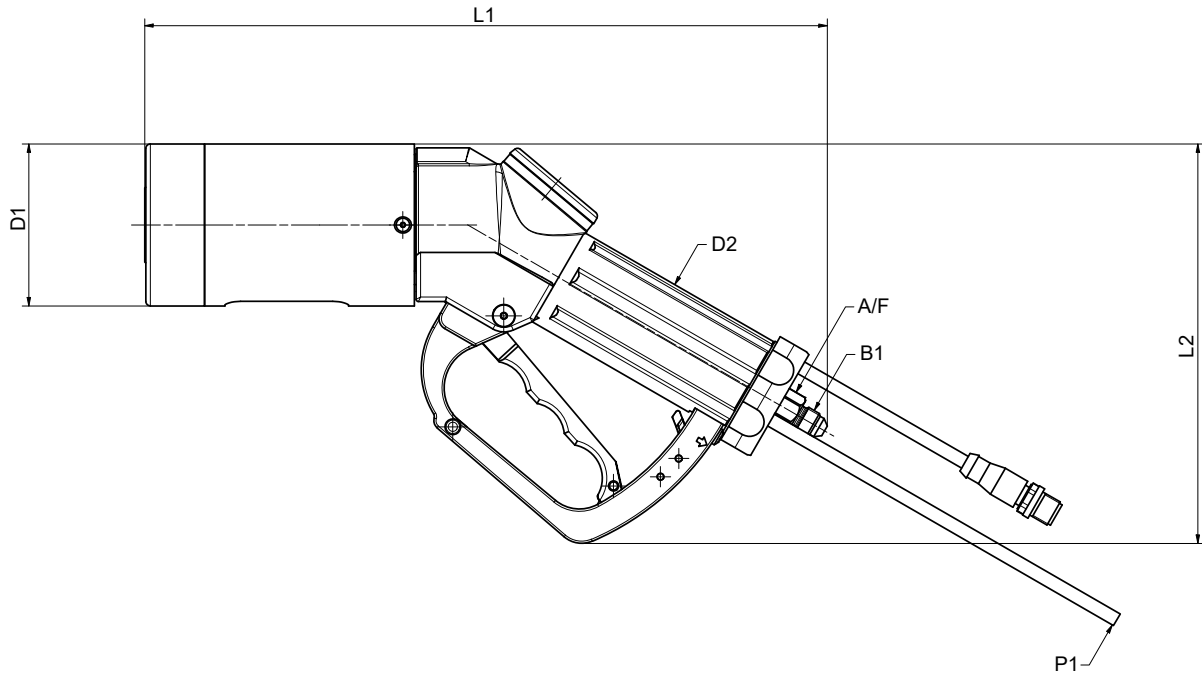

Part no.	Description	Pressure (MAWP)	B1 (male thread)	P1	L1	L2	D1	D2	A/F
C1-188781	TK20-S3 H ₂ 35 MPa ENR Medium-Flow	48.125 MPa	UNF 7/16"-20*	6/4	304	178	72	46	15

* according to SAE J514 with 37° outer cone

Fueling assemblies consisting of fueling nozzle, hose set and breakaway coupling are available on request.

» Fueling nozzle TK20-S3 H₂ 35 MPa ENR Medium-Flow

ACCESSORIES

The following accessories are available for the WEH® TK20-S2 H₂ 35 MPa ENR fueling nozzle:

Hose set

Hose set for connecting fueling nozzle and TSA1 H₂ breakaway coupling, complete with filling hose, data cable, purging line and braided protection hose as cover.

Design filling hose: max. operating pressure PS: 49 MPa / nominal bore fitting (TNW): 4.5 mm / media temperature range: -40°C up to +85°C



Part no.	B1/B2 (female thread)	P1/P2	Hose length
E68-174299	UNF 7/16"-20*	Ø 6/4 mm	3 m
E68-174300	UNF 7/16"-20*	Ø 6/4 mm	4 m
E68-174301	UNF 7/16"-20*	Ø 6/4 mm	5 m

* according to SAE JIC, 37° sealing cone * according to SAE JIC, 37° sealing cone

For additional accessories such as service receptacle and mountings, see pages 18 and 19.

SPARE PARTS

Various parts are available as spares for the WEH® TK20-S3 H₂ 35 MPa ENR Medium-Flow Fueling nozzle.

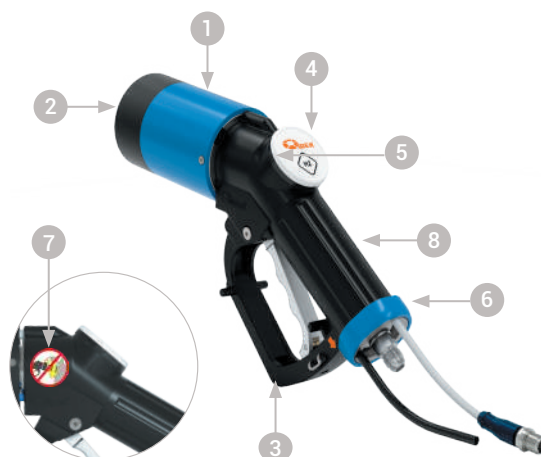

Part No.	Description
C1-189532	1 Impact protection sleeve (incl. screws)
C1-189535	2 IR data interface ATEX, NEC, KTL, CCC (incl. O-ring and screws)
C1-189537	3 Hand grip (incl. locking lever, clamp and screws)
C1-161748	4 Logo cap
C1-59738	5 Logo plate
C1-186082	6 Clamping nut for protective hose
C1-157491	7 Label
C1-189538	8 Handle protector (incl. screws)
On request	Maintenance spray

When ordering please specify the part no. engraved on the fueling nozzle.

» Fueling nozzle TK20-S3 H₂ 35 MPa Medium-Flow



DESCRIPTION



Features

- Type C nozzle acc. to SAE J2600 resp. ISO 17268
- Very high flow rate
- Easy operation / single-handed operation
- Max. allowable operating pressure 48.125 MPa (MAWP according to ISO 19880-1:2020)
- Integrated purging line for nitrogen flushing
- WEH® EASY-TURN 250° swivel joint
- Optimized impact protection
- Plastic thermal protection
- Hand grip with magnet
- Compatible with pressure stage H35 Medium-Flow according to ISO 17268-1:2025 (see table below)

The WEH® TK20-S3 H₂ 35 MPa Medium-Flow Fueling nozzle was developed for fast filling of cars with compressed, gaseous hydrogen (CGH₂). Through to the larger nominal width, refueling with 120 g/s or higher is possible. In addition, this filling nozzle is designed for a maximum operating pressure of 48.125 MPa (= MAWP according to ISO 19880-1:2020).

The fueling nozzle is additionally equipped with a purging line that allows purging with nitrogen during and after refueling process. This can prevent ingress of moisture and the formation of ice crystals during filling with precooled hydrogen.

The WEH® TK20-S3 H₂ 35 MPa Medium-Flow offers optimum safety for the operator thanks to the locking mechanism. The Fueling nozzle remains connected to the receptacle until the locking mechanism is released by the operator.

Application

Fueling nozzle for rapid filling of buses and trucks with hydrogen in self-service operation.

		TN H ₂ (Except TN5 H ₂)				
		25 MPa	35 MPa	35 MPa MF*	35 MPa HF**	70 MPa
TK20-S3 H ₂ 35 MPa Medium-Flow	35 MPa			✓	✓	

*MF = Medium-Flow acc. to ISO 17268-1:2025
**HF = High-Flow acc. to ISO 17268:2012

» Fueling nozzle TK20-S3 H₂ 35 MPa Medium-Flow

TECHNICAL DATA

Characteristics	Basic version
Purging line Outer / inner diameter	6/4 mm
Nominal Pressure	PN = 35 MPa
Max. Allowable Operating Pressure	MAWP = 48.125 MPa according to ISO 17268 (PS = 481.25 bar)
Medium*	Hydrogen
Media Temperature Range	-40°C up to +85°C
Ambient Temperature Range	-40°C up to +85°C
Material	Corrosion resistant
Sealing Material	Hydrogen resistant
Nozzle Type	Type C acc. to SAE J2600:2015 and previous resp. ISO 17268:2020 and previous
Coding	H35MF according to ISO 17268-1:2025
Design	With plastic thermal protection Optimized impact protection Integrated purging line Hand grip with magnet
Weight	Approx. 2.65 kg
Medium for Purging	Nitrogen or compressed air
Media Temperature Range Purging Medium	-40°C to +85°C (most effective >0°C)
Flow Rate During Purging	500 NI/h at max. 12 bar purging pressure
Conformity / Tests / Approvals	Design validation based on ISO 17268-1:2025

* Suitable for pre-cooled hydrogen

» Fueling nozzle TK20-S3 H₂ 35 MPa Medium-Flow

ORDERING | WEH® TK20-S3 H₂ 35 MPa Medium-Flow Fueling nozzle
approx. dimensions (mm)

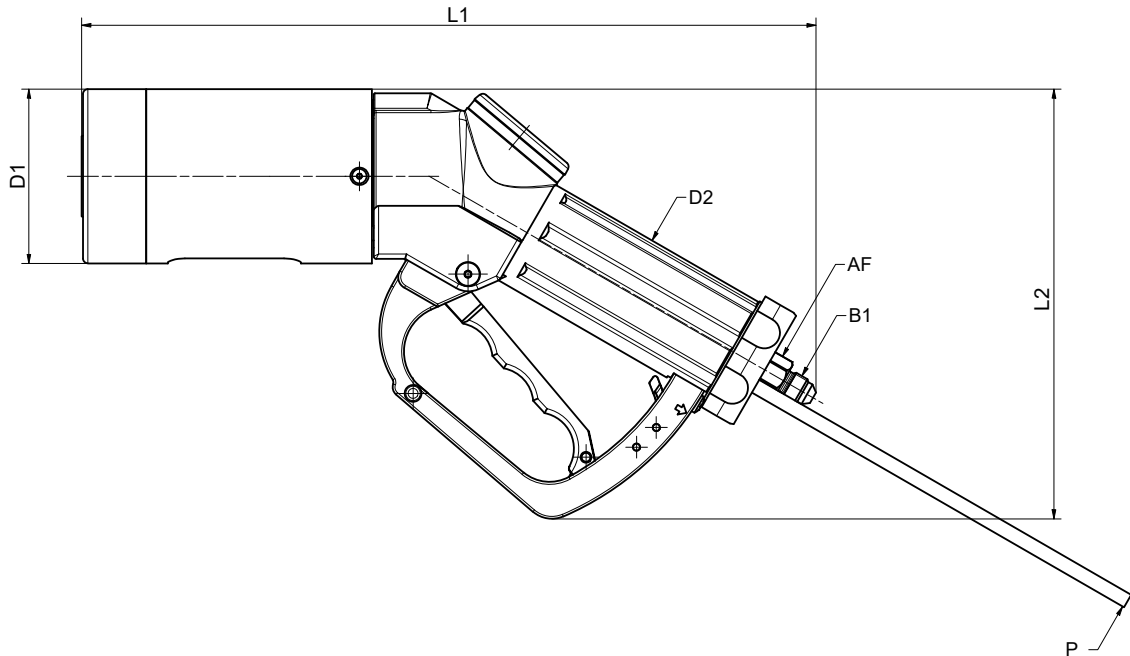

Part no.	Description	Pressure (MAWP)	B1 (male thread)	P1	L1	L2	D1	D2	AF
C1-188784	TK20-S3 H ₂ 35 MPa Medium-Flow	48.125 MPa	UNF 7/16"-20*	6/4	304	178	72	46	15

* according to SAE J514 with 37° outer cone

Fueling assemblies consisting of fueling nozzle, hose set and breakaway coupling are available on request.

» Fueling nozzle TK20-S3 H₂ 35 MPa Medium-Flow

ACCESSORIES

The following accessories are available for the WEH® TK20-S3 H₂ 35 MPa Medium-Flow Fueling nozzle:

Hose set

Hose set for connecting fueling nozzle and TSA1 H₂ breakaway coupling, complete with filling hose, purging line and braided protection hose as cover.

Design filling hose: max. operating pressure PS: 49 MPa / nominal bore fitting (TNW): 4.5 mm / media temperature range: -40°C up to +85°C



Part no.	B1/B2 (female thread)	P1/P2	Hose length
C1-189989	UNF 7/16"-20*	Ø 6/4 mm	3 m
C1-189990	UNF 7/16"-20*	Ø 6/4 mm	4 m
C1-189991	UNF 7/16"-20*	Ø 6/4 mm	5 m

* according to SAE JIC, 37° sealing cone

For additional accessories such as service receptacle and mountings, see pages 18 and 19.

SPARE PARTS

Various parts are available as spares for the WEH® TK20-S3 H₂ 35 MPa Medium-Flow fueling nozzle.



Part No.	Description
C1-189532	1 Impact protection sleeve (incl. screws)
C1-189537	2 Hand grip (incl. locking lever, clamp and screws)
C1-161748	3 Logo cap
C1-59738	4 Logo plate
C1-186082	5 Clamping nut for protective hose
C1-157491	6 Label
C1-189538	7 Handle protector (incl. screws)
On request	Maintenance spray

When ordering please specify the part no. engraved on the fueling nozzle.

» Fueling nozzle TK16 H₂ ENR

DESCRIPTION



Features

- Type A acc. to SAE J2600 resp. ISO 17268
- Exchangeable data interface (ENR)
- WEH EASY-TURN® 240° swivel joint for actuation lever
- Easy operation
- High flow rate → short filling times
- Recirculation of the vented gas
- Plastic thermal protection
- WEH® Jaw locking mechanism
- High-grade materials
- Coding for pressure range / gas type (acc. to table below)

With the WEH® TK16 H₂ ENR the user has a fueling nozzle for hydrogen that makes refueling cars with compressed gaseous hydrogen (CGH₂) even easier than before. The fueling nozzle with exchangeable data interface is easy to operate and thus increases operator comfort.

The integrated swivel joint is located directly on the actuation lever, making it easy to rotate the fueling nozzle to the optimum connection position. The actuating lever can be switched with little effort when connecting and disconnecting.

The internal coding for pressure range and gas type ensures that the TK16 H₂ ENR can be connected to the compatible WEH® Receptacles acc. to the opposite table and also prevents the risk of confusion with natural gas. Furthermore, the fueling nozzle has an exchangeable interface (infrared) for data transfer between the vehicle and the fueling station.

The WEH® TK16 H₂ ENR offers optimum safety for the operator. The fueling nozzle remains connected to the receptacle until the gas between inlet valve and receptacle is depressurized.

		TN H ₂ (except TN5 H ₂)				
		25 MPa	35 MPa	35 MPa MF*	35 MPa HF**	70 MPa
TK16 H ₂ ENR	35 MPa		✓	✓	✓	✓
	35 MPa					

* MF = Medium-Flow acc. to ISO 17268-1:2025
** HF = High-Flow acc. to ISO 17268:2012

Application

Fueling nozzle for hydrogen fast filling of cars at self-service fueling stations.

TECHNICAL DATA

Characteristics	Basic version
Technical nominal size (TNW)	8 mm
Nominal Pressure	PN = 35 MPa
Max. allowable operating Pressure	PS = 45 MPa
Media temperature range	-20°C up to +85°C
Ambient temperature range	-40°C up to +85°C
Material	Corrosion resistant
Sealing material	Hydrogen resistant
Nozzle type	Type A acc. to SAE J2600:2015 and previous resp. ISO 17268:2012 and previous
Design	With plastic thermal protection, gas recirculation and exchangeable data interface acc. to SAE J2799
Weight	Approx. 2.4 kg
Conformity / Tests / Approvals	Fueling nozzle: tests acc. to SAE J2600:2002 IR data interface: SAE J2799 and ATEX, NEC, KTL and CCC

Other designs on request

» Fueling nozzle TK16 H₂ ENR

ORDERING | WEH® TK16 H₂ ENR

approx. dimensions (mm)

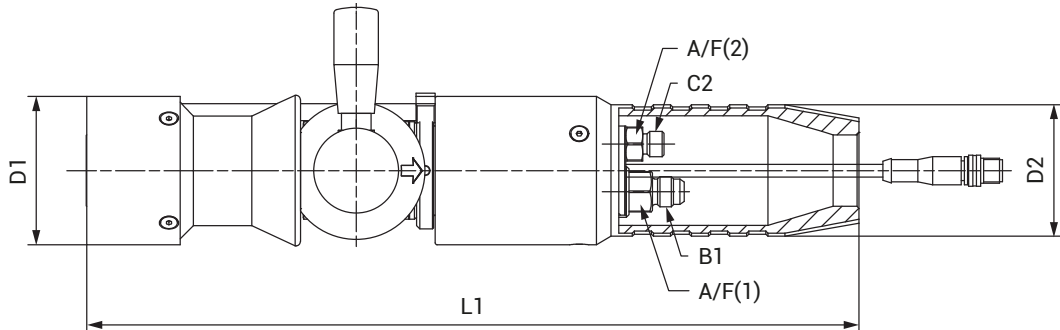

Part No.	Description	Pressure (MAWP)	B1 (male thread)	C2 (male thread)	L1	D1	D2	A/F(1)	A/F(2)
C1-103471-X01	TK16 H ₂ ENR	45 MPa	UNF 9/16"-18*	M12x1.5	370	70	62	19	16

* acc to. SAE J514, 37° cone

Fueling assemblies consisting of fueling nozzle, hose set and breakaway coupling are available on request.

ACCESSORIES

The following accessories are available for the WEH® TK16 H₂ ENR Fueling nozzle:

Hose set

Hose set for connecting fueling nozzle and TSA1 H₂ breakaway coupling, complete with filling and venting hose, hose fittings, plastic spiral hose and cable for data interface. Not suitable for refueling with pre-cooled hydrogen acc. to SAE J2601. Design filling/venting hose: max. operating pressure PS: 45 MPa / nominal bore fitting (TNW): 4.5 mm (filling hose) resp. 2 mm (venting hose) / media temperature range: -20°C up to +90°C

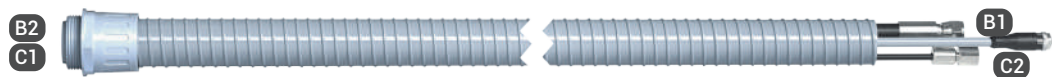

Part No.	B1/B2 (female thread)	C1/C2 (female thread)	Hose length
C1-90698	UNF 9/16"-18*	M12x1.5	3 m
C1-94428	UNF 9/16"-18*	M12x1.5	4 m
C1-94429	UNF 9/16"-18*	M12x1.5	5 m

* acc. to SAE JIC, 37° cone

» Fueling nozzle TK16 H₂ ENR

Dispenser mounting

Mounting for safe attachment of the fueling nozzle to the dispenser.

Part no.	Description
On request	Dispenser mounting

WEH® TNS1 H₂ Service receptacle

To prevent damage in the fueling nozzle while purging or leak testing during maintenance in the course of which pressure is applied, we recommend the use of a service receptacle. The receptacle also protects the fueling nozzle from dirt ingress whilst not in use.



Part no.	Description
C1-148079	TNS1 H ₂ Service receptacle incl. protection cap

WEH® Breakaway coupling

For the suitable TSA1 H₂ breakaway coupling, please see page 72.

Data cable

Part no.	Description	Hose length
E68-96194	Data cable suitable for 4 m hose set	4.45 m
E68-96193	Data cable for connecting with the converter	3.45 m

Other lengths on request

» Fueling nozzle TK16 H₂ ENR

SPARE PARTS

Various parts are available as spares for the WEH® TK16 H₂ ENR Fueling nozzle.



Part No.	Description
W180567	1 Impact protection (incl. 4 countersunk screws)
W180569	2 IR data interface (incl. o-ring and grub screw)
W72504	3 Actuation lever
E80-163068	4 Cover plate
W150340	5 Protection sleeve (incl. 3 countersunk screws)
On request	Maintenance spray

» Fueling nozzle TK16 H₂

DESCRIPTION



Features

- Type A acc. to SAE J2600 resp. ISO 17268
- Compatible with WEH[®] TN1 H₂ Receptacle profile
- WEH EASY-TURN[®] 360° swivel joint for actuation lever
- Easy operation
- High flow rate → short filling times
- Recirculation of the vented gas
- Plastic thermal protection
- WEH[®] Jaw locking mechanism
- High-grade materials
- Coding for pressure range / gas type (acc. to table below)

The WEH[®] TK16 H₂ Fueling nozzle makes refueling cars with compressed gaseous hydrogen (CGH₂) so much easier. The TK16 H₂ is very light in weight and therefore easy to operate.

The integrated swivel joint is located directly on the actuation lever, making it easy to rotate the fueling nozzle to the optimum connection position. The actuating lever can be switched with little effort when connecting and disconnecting.

The internal coding for pressure range and gas type ensures that the TK16 H₂ can be connected to the compatible WEH[®] Receptacles acc. to the opposite table and also prevents the risk of confusion with natural gas.

The WEH[®] TK16 H₂ offers optimum safety for the operator.

The fueling nozzle remains connected to the receptacle until the gas between inlet valve and receptacle is depressurized.

		TN H ₂ (Except TN5 H ₂)				
		25 MPa	35 MPa	35 MPa MF*	35 MPa HF*	70 MPa
TK16 H ₂	25 MPa	✓	✓	✓	✓	✓
	35 MPa		✓	✓	✓	✓

* MF = Medium-Flow acc. to ISO 17268-1:2025
**HF = High-Flow acc. to ISO 17268:2012

Application

Fueling nozzle for hydrogen fast filling of cars at self-service fueling stations.

TECHNICAL DATA

Characteristics	Basic version
Technical nominal size (TNW)	8 mm
Nominal Pressure	PN = 25 MPa PN = 35 MPa
Max. allowable operating Pressure	PS = 45 MPa
Media temperature range	-20°C up to +85°C
Ambient temperature range	-40°C up to +85°C
Material	Corrosion resistant
Sealing material	Hydrogen resistant
Nozzle type	Type A acc. to SAE J2600:2015 and previous resp. ISO 17268:2012 and previous
Design	With plastic thermal protection and gas recirculation
Weight	Approx. 1.8 kg
Conformity / Tests / Approvals	Tests acc. to SAE J2600:2002

Other designs on request

» Fueling nozzle TK16 H₂

ORDERING | WEH® TK16 H₂ Fueling nozzle

approx. dimensions (mm)

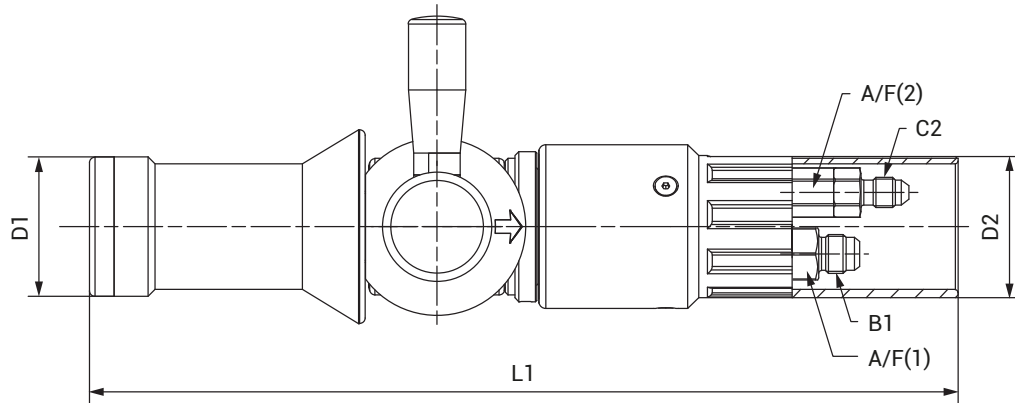

Part No.	Description	Pressure (MAWP)	B1 (male thread)	C2 (male thread)	L1	D1	D2	A/F(1)	A/F(2)
C1-45695-X4-X01	TK16 H ₂ 25 MPa	35 MPa	UNF 9/16"-18*	UNF 7/16"-20*	319	51	52	19	16
C1-45696-X5-X01	TK16 H ₂ 35 MPa	45 MPa	UNF 9/16"-18*	UNF 7/16"-20*	324	51	52	19	16

* acc. to SAE J514, 37° cone

Fueling assemblies consisting of fueling nozzle, hose set and breakaway coupling are available on request.

ACCESSORIES

The following accessories are available for the WEH® TK16 H₂ Fueling nozzle:

Hose set

Hose set for connecting fueling nozzle and TSA1 H₂ breakaway coupling, complete with filling and venting hose, fittings and press-fittings supported by coil spring stubs. Not suitable for refueling with pre-cooled hydrogen acc. to SAE J2601. Design filling/venting hose: max. operating pressure PS: 45 MPa / technical nominal size (TNW): 4.5 mm / media temperature range: -20°C up to +90°C



Part No.	B1/B2 (female thread)	C1/C2 (female thread)	Hose length
C1-60917	UNF 9/16"-18*	UNF 7/16"-20*	3 m
C1-60920	UNF 9/16"-18*	UNF 7/16"-20*	4 m
C1-60923	UNF 9/16"-18*	UNF 7/16"-20*	5 m

* acc. to SAE JIC, 37° cone

» Fueling nozzle TK16 H₂

Dispenser mounting

Mounting for safe attachment of the fueling nozzle to the dispenser.

Part No.	Description
On request	Dispenser mounting

WEH® TNS1 H₂ Service receptacle

To prevent damage in the fueling nozzle while leak testing during maintenance in the course of which pressure is applied, we recommend the use of a service receptacle. The receptacle also protects the fueling nozzle from dirt ingress whilst not in use.



Part no.	Description
C1-148079	TNS1 H ₂ Service receptacle incl. protection cap

WEH® Breakaway couplings

For the suitable TSA1 H₂ breakaway coupling or TSA2 H₂ inline breakaway coupling, please see page 72 resp. 78.

» Fueling nozzle TK16 H₂

SPARE PARTS

Various parts are available as spares for the WEH[®] TK16 H₂ Fueling nozzle.



Part No.	Description
E80-176344	1 Impact protection
W72504	2 Actuation lever
E80-163068	3 Cover plate
W136178	4 Protection sleeve (incl. 3 countersunk screws)
On request	Maintenance spray

» Fueling nozzle TK16 H₂ High-Flow with data interface

DESCRIPTION



Features

- Type A acc. to SAE J2600 resp. ISO 17268
- Integrated infrared data interface
- WEH EASY-TURN® 240° swivel joint for actuation lever
- Easy operation
- Increased flow rate → even shorter filling times
- Recirculation of the vented gas
- Plastic thermal protection
- WEH® Jaw locking mechanism
- High-grade materials
- Coding for pressure range / gas type (acc. to table below)

The WEH® TK16 H₂ High-Flow Fueling nozzle with data interface enables an even faster filling of buses and trucks with hydrogen. Due to the increased flow rate, the already short filling times have been shortened even further. The integrated swivel joint is located directly on the actuation lever, making it easy to rotate the fueling nozzle to the optimum connection position. The actuating lever can be switched with little effort when connecting and disconnecting.

The internal coding for pressure range and gas type ensures that the TK16 H₂ High-Flow with data interface can be connected to the compatible WEH® Receptacles acc. to the opposite table and also prevents the risk of confusion with natural gas. Furthermore, the fueling nozzle has an interface (infrared) for data transfer between the vehicle and the fueling station.

The WEH® TK16 H₂ High-Flow with data interface offers optimum safety for the operator. The fueling nozzle remains connected to the receptacle until the gas between inlet valve and receptacle is depressurized.

		TN H ₂ (Except TN5 H ₂)				
		25 MPa	35 MPa	35 MPa MF*	35 MPa HF*	70 MPa
TK16 H ₂ HF IR	35 MPa HF*			✓	✓	

* MF = Medium-Flow acc. to ISO 17268-1:2025
** HF = High-Flow acc. to ISO 17268:2012

Application

Fueling nozzle for hydrogen fast filling of buses and trucks at self-service fueling stations.

TECHNICAL DATA

Characteristics	Basic version
Technical nominal size (TNW)	8 mm
Nominal Pressure	PN = 35 MPa
Max. allowable operating Pressure	MAWP = 45 MPa (PS = 450 bar)
Media temperature range	-20°C up to +85°C
Ambient temperature range	-40°C up to +85°C
Material	Corrosion resistant
Sealing material	Hydrogen resistant
Nozzle type	Type A acc. to SAE J2600:2015 and previous resp. ISO 17268:2012 and previous
Design	With plastic thermal protection, gas recirculation and data interface acc. to SAE J2601
Weight	Approx. 2.4 kg
Conformity / Tests / Approvals	Fueling nozzle: tests acc. to SAE J2600:2002 IR data interface: ATEX; NEC on request

Other designs on request

» Fueling nozzle TK16 H₂ High-Flow with data interface

ORDERING | WEH® TK16 H₂ High-Flow Fueling nozzle with data interface

approx. dimensions (mm)

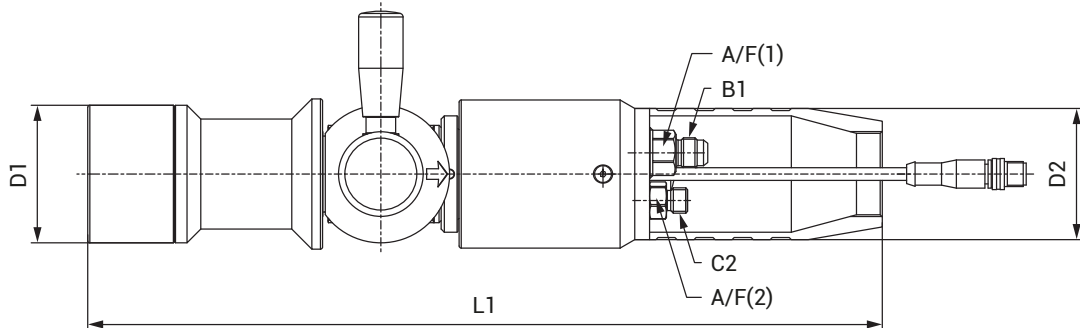

Part No.	Description	Pressure (MAWP)	B1 (male thread)	C2 (male thread)	L1	D1	D2	A/F(1)	A/F(2)
C1-94315-X01	TK16 H ₂ High-Flow (ATEX IR data interface)	45 MPa	UNF 9/16"-18*	M12x1.5	381	65	62	19	16

* acc. to SAE J514, 37° cone

On request the TK16 H₂ High-Flow Fueling nozzle with data interface is also available with NEC approval. Fueling assemblies consisting of fueling nozzle, hose set and breakaway coupling are available on request.

ACCESSORIES

The following accessories are available for the WEH® TK16 H₂ High-Flow Fueling nozzle with data interface:

Hose set

Hose set for connecting fueling nozzle and TSA1 H₂ breakaway coupling, complete with filling and venting hose, hose fittings, plastic spiral hose and cable for data interface. Not suitable for refueling with pre-cooled hydrogen acc. to SAE J2601.

Design filling/venting hose: max. operating pressure PS: 45 MPa / nominal bore fitting (TNW): 4.5 mm (filling hose) resp. 2 mm (venting hose) / media temperature range: -20°C up to +90°C

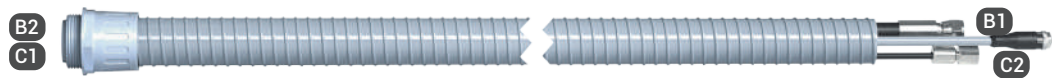

Part No.	B1/B2 (female thread)	C1/C2 (female thread)	Hose length
C1-90698	UNF 9/16"-18*	M12x1.5	3 m
C1-94428	UNF 9/16"-18*	M12x1.5	4 m
C1-94429	UNF 9/16"-18*	M12x1.5	5 m

* acc. to SAE JIC, 37° cone

» Fueling nozzle TK16 H₂ High-Flow with data interface

Dispenser mounting

Mounting for safe attachment of the fueling nozzle to the dispenser.

Not switch actuated dispenser mounting with protection of front sleeve

approx. dimensions (mm)

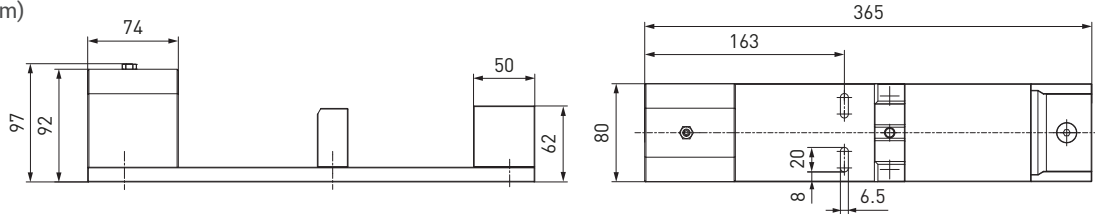

Switch actuated dispenser mounting with weather protection

approx. dimensions (mm)

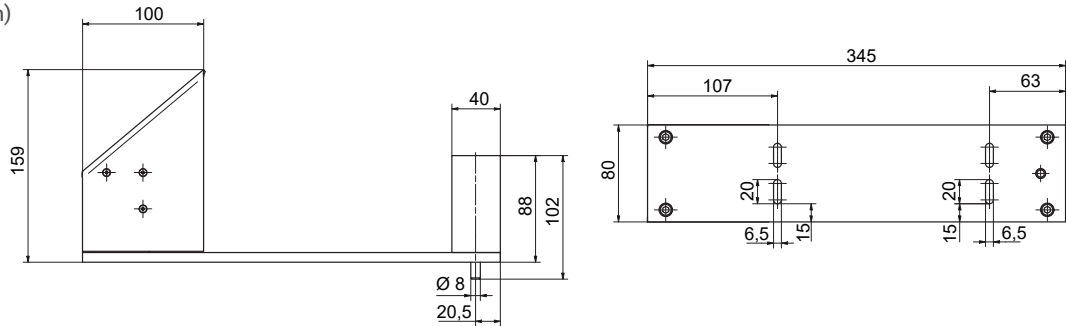

Switch actuated dispenser mounting with weather protection and angle plate 15°

approx. dimensions (mm)

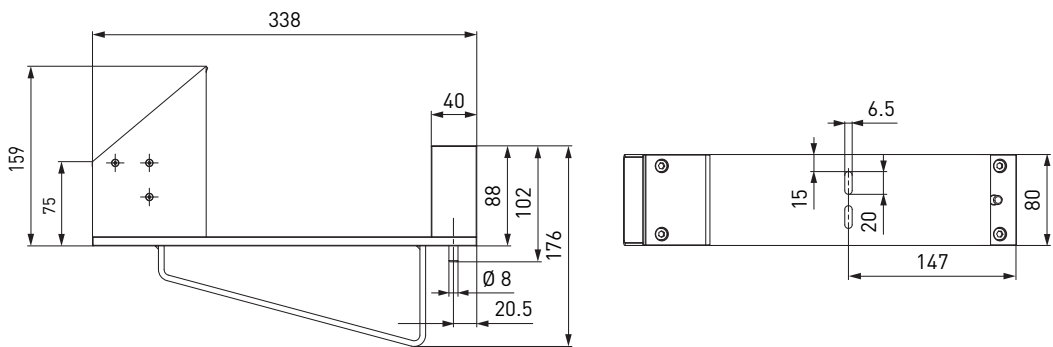

Part No.	Description
C1-94671	Dispenser mounting (not switch actuated) with protection of front sleeve
C1-175692	Dispenser mounting (switch actuated) with weather protection
C1-114632	Dispenser mounting (switch actuated) with weather protection and angle plate 15°

» Fueling nozzle TK16 H₂ High-Flow with data interface

WEH® TNS1 H₂ Service receptacle

To prevent damage in the fueling nozzle while leak testing during maintenance in the course of which pressure is applied, we recommend the use of a service receptacle. The receptacle also protects the fueling nozzle from dirt ingress whilst not in use.



Part no.	Description
C1-148079	TNS1 H ₂ Service receptacle incl. protection cap

WEH® Breakaway coupling

For the suitable TSA1 H₂ breakaway coupling, please see page 72.

Data cable

Part no.	Description	Hose length
E68-96194	Data cable suitable for 4 m hose set	4.45 m
E68-96193	Data cable for connecting with the converter	3.45 m

Other lengths on request

SPARE PARTS

Various parts are available as spares for the WEH® TK16 H₂ High-Flow Fueling nozzle with data interface.



Part No.	Description
W72504	1 Actuation lever
E80-163068	2 Cover plate
W150340	3 Protection sleeve (incl. 3 countersunk screws)
On request	Maintenance spray

» Fueling nozzle TK16 H₂ High-Flow

DESCRIPTION



Features

- Type A acc. to SAE J2600 resp. ISO 17268
- Compatible with WEH[®] TN1 H₂ High-Flow Receptacle profile
- WEH EASY-TURN[®] 360° swivel joint for actuation lever
- Easy operation
- Increased flow rate → even shorter filling times
- Recirculation of the vented gas
- Plastic thermal protection
- WEH[®] Jaw locking mechanism
- High-grade materials
- Coding for pressure range / gas type (acc. to table below)

The WEH[®] TK16 H₂ High-Flow Fueling nozzle enables an even faster filling of buses and trucks with hydrogen. Due to the increased flow rate, the already short filling times have been shortened even further. The integrated swivel joint is located directly on the actuation lever, making it easy to rotate the fueling nozzle to the optimum connection position. The actuating lever can be switched with little effort when connecting and disconnecting.

The internal coding for pressure range and gas type ensures that the TK16 H₂ High-Flow can be connected to the compatible WEH[®] Receptacles acc. to the opposite table and also prevents the risk of confusion with natural gas.

The WEH[®] TK16 H₂ High-Flow offers optimum safety for the operator. The fueling nozzle remains connected to the receptacle until the gas between inlet valve and receptacle is depressurized.

		TN H ₂ (Except TN5 H ₂)				
		25 MPa	35 MPa	35 MPa MF*	35 MPa HF**	70 MPa
TK16 H ₂ HF	35 MPa HF*			✓	✓	

* MF = Medium-Flow acc. to ISO 17268-1:2025
** HF = High-Flow acc. to ISO 17268:2012

Application

Fueling nozzle for hydrogen fast filling of buses and trucks at self-service fueling stations.

TECHNICAL DATA

Characteristics	Basic version
Technical nominal size (TNW)	8 mm
Nominal Pressure	PN = 35 MPa
Max. allowable operating Pressure	MAWP = 45 MPa (PS = 450 bar)
Media temperature range	-20°C up to +85°C
Ambient temperature range	-40°C up to +85°C
Material	Corrosion resistant
Sealing material	Hydrogen resistant
Nozzle type	Type A acc. to SAE J2600:2015 and previous resp. ISO 17268:2012 and previous
Design	With plastic thermal protection and gas recirculation
Weight	Approx. 1.8 kg
Conformity / Tests / Approvals	Tests acc. to SAE J2600:2002

Other designs on request

» Fueling nozzle TK16 H₂ High-Flow

ORDERING | WEH® TK16 H₂ High-Flow Fueling nozzle

approx. dimensions (mm)

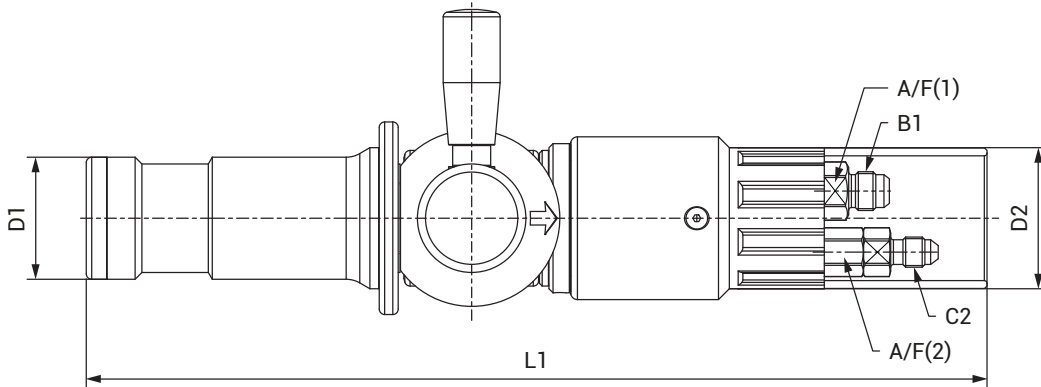

Part No.	Description	Pressure (MAWP)	B1 (male thread)	C2 (male thread)	L1	D1	D2	A/F(1)	A/F(2)
C1-85042-X01	TK16 H ₂ High-Flow	45 MPa	UNF 9/16"-18*	UNF 7/16"-20*	338	45	52	19	16

* acc. to SAE J514, 37° cone

Fueling assemblies consisting of fueling nozzle, hose set and breakaway coupling are available on request.

ACCESSORIES

The following accessories are available for the WEH® TK16 H₂ High-Flow Fueling nozzle:

Hose set

Hose set for connecting fueling nozzle and TSA1 H₂ breakaway coupling, complete with filling and venting hose, fittings and press-fittings supported by coil spring stubs. Not suitable for refueling with pre-cooled hydrogen acc. to SAE J2601.

Design filling/venting hose:

max. operating pressure PS: 45 MPa / technical nominal size (TNW): 4.5 mm / media temperature range: -20°C up to +90°C



Part No.	B1/B2 (female thread)	C1/C2 (female thread)	Hose length
C1-60917	UNF 9/16"-18*	UNF 7/16"-20*	3 m
C1-60920	UNF 9/16"-18*	UNF 7/16"-20*	4 m
C1-60923	UNF 9/16"-18*	UNF 7/16"-20*	5 m

* acc. to SAE JIC, 37° cone

» Fueling nozzle TK16 H₂ High-Flow

Dispenser mounting

Mounting for safe attachment of the fueling nozzle to the dispenser.

Switch actuated (with pin) resp. not switch actuated dispenser mounting

approx. dimensions (mm)

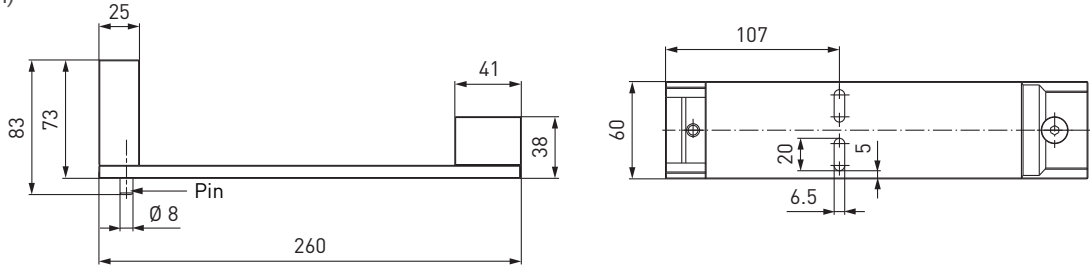

Switch actuated dispenser mounting with weather protection

approx. dimensions (mm)

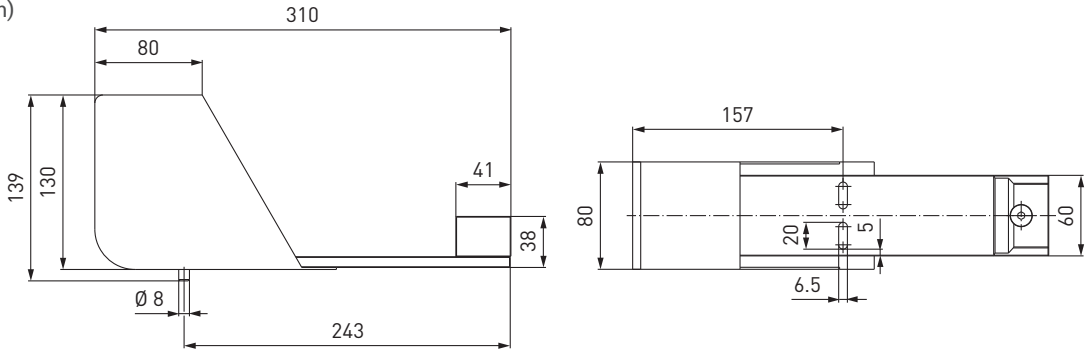

Part No.	Description
C1-86860	Dispenser mounting (switch actuated)
C1-109880	Dispenser mounting (not switch actuated)
C1-109678	Dispenser mounting (switch actuated) with weather protection

WEH® TNS1 H₂ Service receptacle

To prevent damage in the fueling nozzle while leak testing during maintenance in the course of which pressure is applied, we recommend the use of a service receptacle. The receptacle also protects the fueling nozzle from dirt ingress whilst not in use.



Part no.	Description
C1-148079	TNS1 H ₂ Service receptacle incl. protection cap

WEH® Breakaway couplings

For the suitable TSA1 H₂ breakaway coupling or TSA2 H₂ inline breakaway coupling, please see page 72 resp. 78.

» Fueling nozzle TK16 H₂ High-Flow

SPARE PARTS

Various parts are available as spares for the WEH® TK16 H₂ High-Flow Fueling nozzle.



Part No.	Description
E80-172676	1 Impact protection
W72504	2 Actuation lever
E80-163068	3 Cover plate
W136178	4 Protection sleeve (incl. 3 countersunk screws)
On request	Maintenance spray

» Breakaway coupling TSA1 H₂

DESCRIPTION

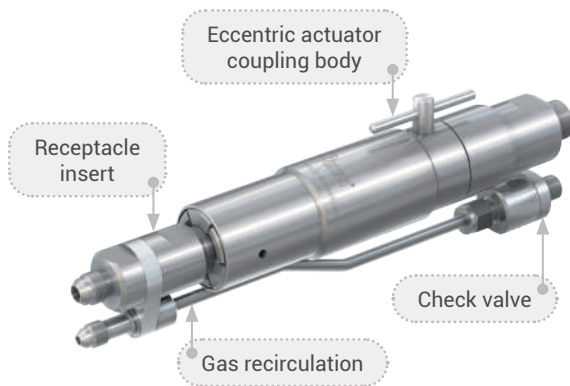

Features

- Reusable without factory servicing
- Installation at the dispenser
- Small compact design
- Version with and without gas recirculation
- Integrated cleanable filter (20 µm or 40 µm)
- Check valve at venting line
- No additional tool necessary

The WEH[®] TSA1 H₂ Breakaway coupling offers additional safety for your car fueling station. The breakaway is installed between the dispenser and the filling hose or dispenser and filling/venting hose.

In the event of unexpected tensile forces, e.g. a vehicle driving away with a connected fueling nozzle, the breakaway separates the connections between dispenser and hose(s) in a controlled manner while sealing both ends.

Damage to the vehicles receptacle, the fueling nozzle and the dispenser can thus be prevented as far as possible. The breakaway coupling can be reused after a functional test.

The integrated filter cleans the hydrogen from dirt ingress and can be cleaned easily and quickly during maintenance.

The WEH[®] TSA1 H₂ Breakaway coupling consists of a coupling body, a receptacle insert and, depending on the version, of a gas recirculation with check valve. A dispenser mounting is available as an accessory.

For fueling nozzle with data interface, the TSA1 H₂ is also available with a data cable that can be mounted on the mounting.

Refueling kits are also available. They consist of a fueling nozzle, hose set, tear-off protection, fuel pump holder, and data cable.

Please inquire for more information.

Application

Breakaway coupling for car hydrogen fueling stations for direct installation at the dispenser.

» Breakaway coupling TSA1 H₂

TECHNICAL DATA

Characteristics	Basic version
Technical nominal size (TNW)	Depending on design
Nominal Pressure	PN = 35 MPa
Max. allowable operating Pressure	MAWP = 49 MPa, 45 MPa according to ISO 19880-1 (PS = 490 bar, 450 bar), depending on design
Media temperature range	TSA1 H ₂ for TK17 H ₂ fueling nozzles: -40°C up to +85°C TSA1 H ₂ for TK16 H ₂ fueling nozzles: -20°C up to +85°C
Ambient temperature range	-40°C up to +85°C
Breakaway force	222 - 667 N
Material	Corrosion resistant stainless steel, aluminum
Sealing material	Hydrogen resistant
Design	Depending on design: With filter (20 µm or 40 µm) With or without gas recirculation With or without dispenser mounting With dispenser mounting and data cable (only versions for fueling nozzles with data interface)

Other designs on request

ORDERING | WEH® TSA1 H₂ Breakaway coupling for TK20-S2 H₂ 35 MPa und TK20-S3 H₂ 35 MPa Medium-Flow
approx. dimensions (mm)

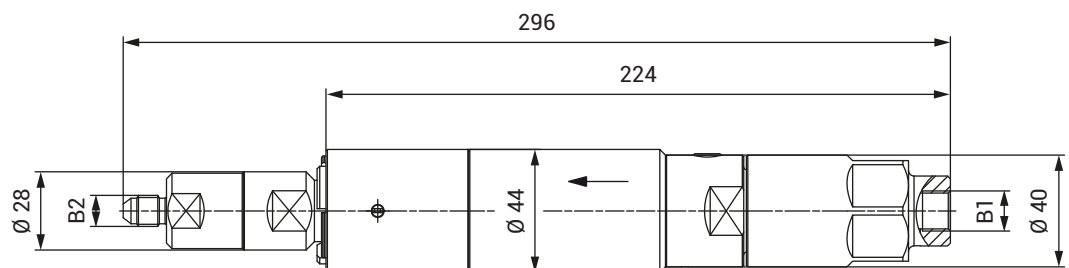

Part No.	Description	TNW	Pressure (MAWP)	B1 (female thread)	B2 (male thread)
C1-174444	TSA1 H ₂ with filter (20 µm)	4 mm	49 MPa	UNF 9/16"-18*	UNF 7/16"-20**

* MP-fitting, 60° inner cone
** acc. to SAE J514, 37° cone

» Breakaway coupling TSA1 H₂

ORDERING | WEH® TSA1 H₂ Breakaway coupling with male thread for TK16 H₂ + High-Flow
approx. dimensions (mm)

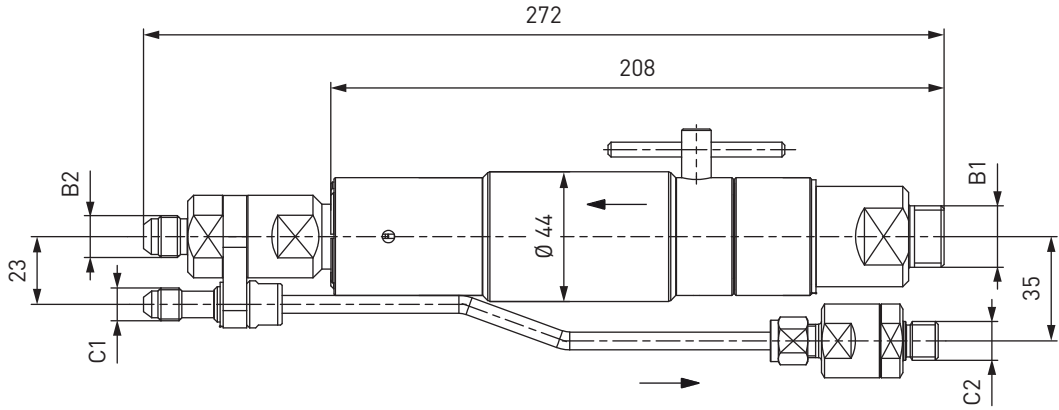

Part No.	Description	TNW	Pressure (MAWP)	B1 (male thread)	B2 (male thread)	C1 (male thread)	C2 (male thread)
C1-18834-X7-X01	TSA1 H ₂ with filter (40 µm)	7 mm	45 MPa	G1/2**	UNF 9/16"-18**	UNF 7/16"-20**	G1/4**
C1-67741-X1-X01	TSA1 H ₂ with filter (20 µm)	7 mm	45 MPa	G1/2**	UNF 9/16"-18**	UNF 7/16"-20**	G1/4**

* acc. to DIN EN ISO 228-1

** acc. to SAE J514, 37° cone

ORDERING | WEH® TSA1 H₂ Breakaway coupling with female thread for TK16 H₂ + High-Flow
approx. dimensions (mm)

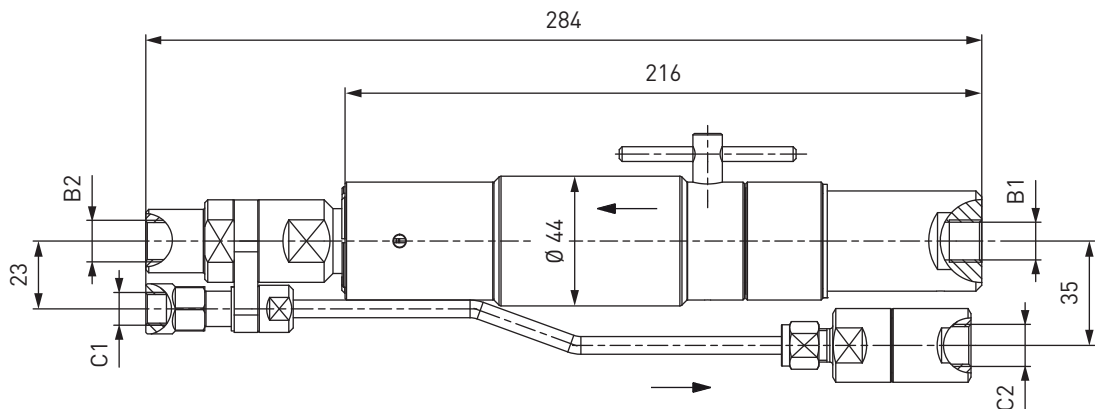

Part No.	Description	TNW	Pressure (MAWP)	B1/B2 (female thread)	C1 (female thread)	C2 (female thread)
C1-99345-X01	TSA1 H ₂ with filter (40 µm)	5 mm	45 MPa	UNF 9/16"-18*	UNF 7/16"-20*	UNF 9/16"-18*

* MP-fitting, 60° inner cone

» Breakaway coupling TSA1 H₂

ORDERING | WEH® TSA1 H₂ Breakaway coupling with male thread for TK16 H₂ + High-Flow

approx. dimensions (mm)

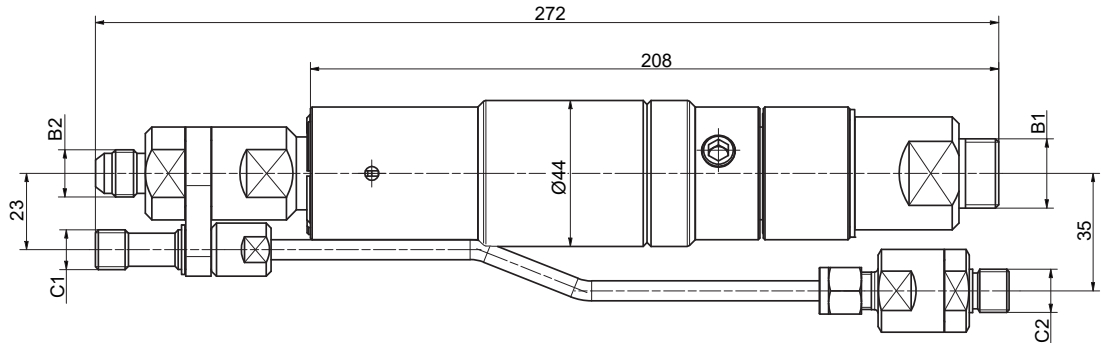

Part No.	Description	TNW	Pressure (MAWP)	B1 (male thread)	B2 (male thread)	C1 (male thread)	C2 (male thread)
C1-91911-X01	TSA1 H ₂ with filter (40 µm)	8 mm	45 MPa	G1/2**	UNF 9/16"-18**	M12x1.5***	G1/4**

* according to DIN EN ISO 228-1

** according to SAE J514, 37° cone

*** 24° inner cone

» Breakaway coupling TSA1 H₂

ACCESSORIES

The following accessories are available for the WEH® TSA1 H₂ breakaway coupling:

Dispenser mounting

The breakaway coupling can also be used in combination with a mounting. The mounting is mounted on the dispenser. A guide tube is integrated into the bracket, which ensures a straight pull force regardless of the direction of pull.

Dispenser mounting for fueling nozzles without data interface

approx. dimensions (mm)

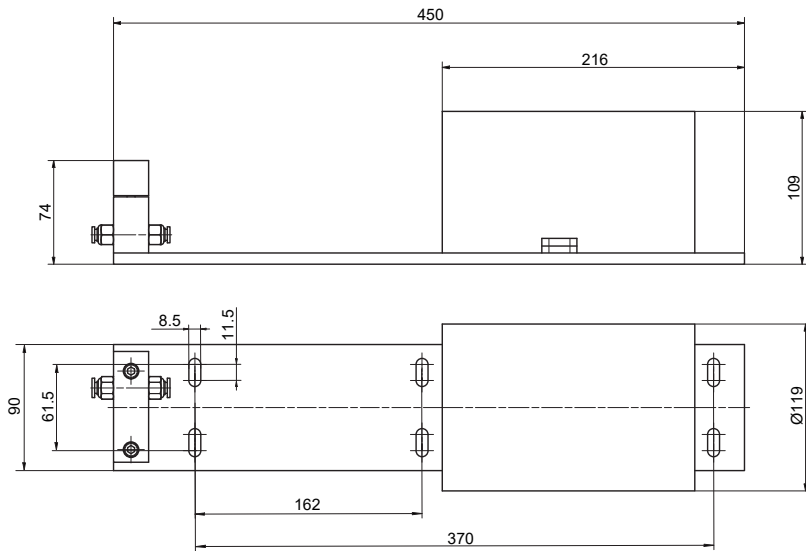

Part No.	Description
C1-191133	Dispenser mounting for TSA1 H ₂ for fueling nozzles without data interface

Dispenser mounting for fueling nozzles with data interface

approx. dimensions (mm)

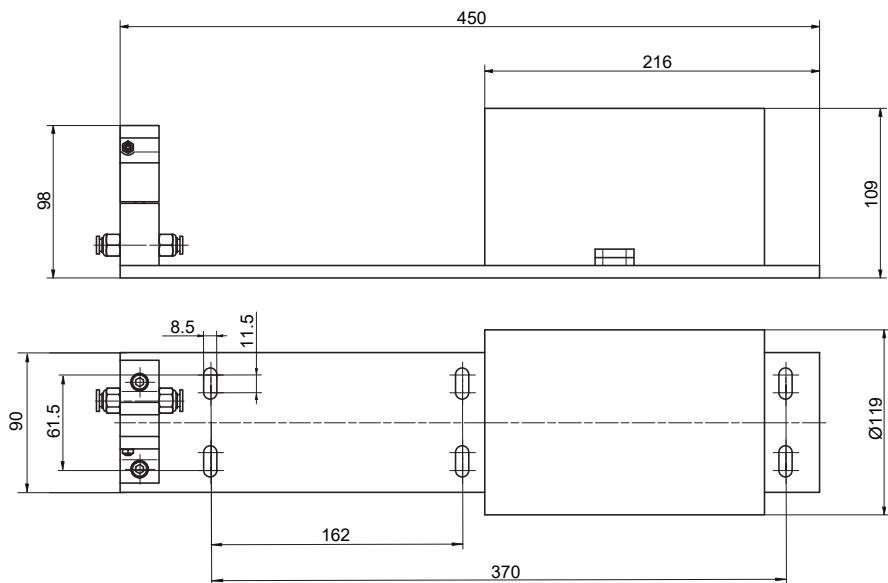

Part No.	Description
C1-191132	Dispenser mounting for TSA1 H ₂ for fueling nozzles with data interface

» Breakaway coupling TSA1 H₂

Data cable

Part No.	Description	Length
C1-96193	Data cable (for dispenser side)	3.45 m

Hoses

Suitable hoses for the TSA1 H₂ breakaway coupling are available on request.

Mounting for braided protection hose

Mounting for attachment of the braided protection hose to the TSA1 H₂ without gas recirculation.

Part No.	Description
C1-171845	Mounting for braided protection hose (suitable for C1-174444, C1-174446, C1-174456)

SPARE PARTS

Various parts are available as spares for the WEH® TSA1 H₂ Breakaway coupling.

Part No.	Description
W159176	Receptacle insert for TSA1 H ₂ without gas recirculation (C1-174444, C1-174446, C1-174456)
W94249	Receptacle insert for TSA1 H ₂ with gas recirculation (C1-18834-X7-X01, C1-67741-X1-X01)
W108401	Receptacle insert for TSA1 H ₂ with gas recirculation (C1-99345-X01)
W108154	Receptacle insert for TSA1 H ₂ with gas recirculation (C1-90679-X01)
B200B-123477	Spare seals set for receptacle insert W159176
B200B-119056	Spare seals set for receptacle insert W94249, W108401, W108154
W139032	Spare parts set consisting of a gas recirculation tube (length: approx. 195 mm) and a firmly mounted check valve (C1-18834-X7-X01, C1-67741-X1-X01, C1-90679-X01)
W140024	Spare parts set consisting of a gas recirculation tube (length: approx. 195 mm) and a firmly mounted check valve (C1-99345-X01)
E69-9061	Wire filter insert 40 µm (incl. spring and o-ring)
W67754	Wire filter insert 20 µm (incl. spring and o-ring)

» Inline breakaway coupling TSA2 H₂

DESCRIPTION

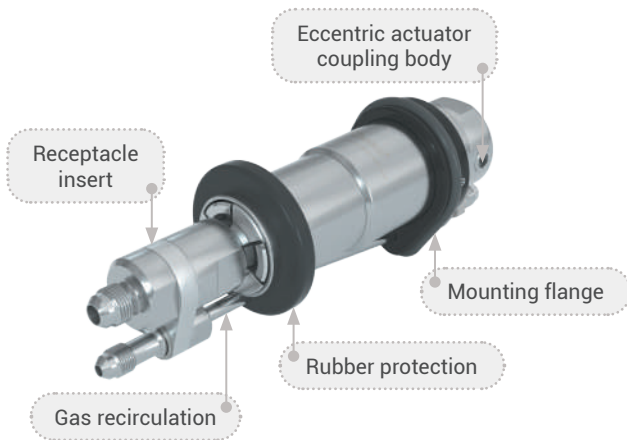

Features

- Reusable without factory servicing
- Installable between the filling and venting hoses
- Small compact design
- Rubber protection and mounting flange incl. impact protection
- Eccentric actuation via Allen wrench

With the WEH[®] TSA2 H₂ Breakaway coupling, an inline breakaway coupling is also available for car refueling stations which is installed between the filling and venting hoses.

In the event of unexpected tensile forces, e.g. a vehicle driving away with a connected fueling nozzle, the breakaway separates the connections between dispenser and hoses in a controlled manner while sealing both ends. Damage to the vehicle's receptacle, the fueling nozzle and the dispenser can thus be prevented as far as possible. The breakaway coupling can be reused after a functional test.

The WEH[®] Breakaway coupling consists of a coupling body, a receptacle insert and a gas recirculation.

When using a TSA2 H₂ inline breakaway coupling, we additionally recommend the WEH[®] TSF2 H₂ Filter (see page 94). The filter protects the breakaway coupling and fueling nozzle from dirt ingress.

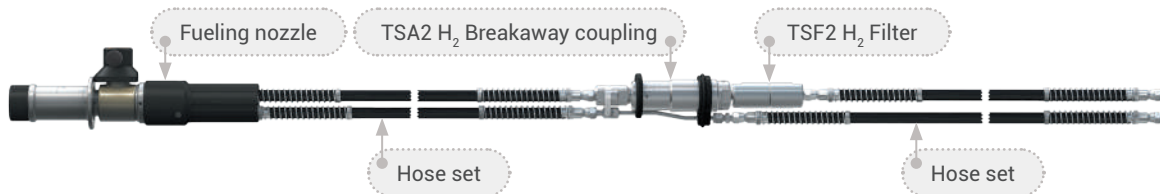

On request we also offer fueling assemblies consisting of fueling nozzle, hose set and inline breakaway coupling.

Application

Inline breakaway coupling for car hydrogen fueling stations for installation between the filling and venting hoses.

TECHNICAL DATA

Characteristics	Basic version
Technical nominal size (TNW)	8 mm
Nominal Pressure	PN = 35 MPa
Max. allowable operating Pressure	MAWP = 45 MPa (PS = 450 bar)
Media temperature range	-20°C up to +85°C
Ambient temperature range	-40°C up to +85°C
Breakaway force	222 - 667 N
Material	Corrosion resistant stainless steel, aluminum
Sealing material	Hydrogen resistant
Design	With gas recirculation

Other designs on request

» Inline breakaway coupling TSA2 H₂

ORDERING | WEH® TSA2 H₂ Inline breakaway coupling for TK16 H₂ (+ High-Flow)

approx. dimensions (mm)

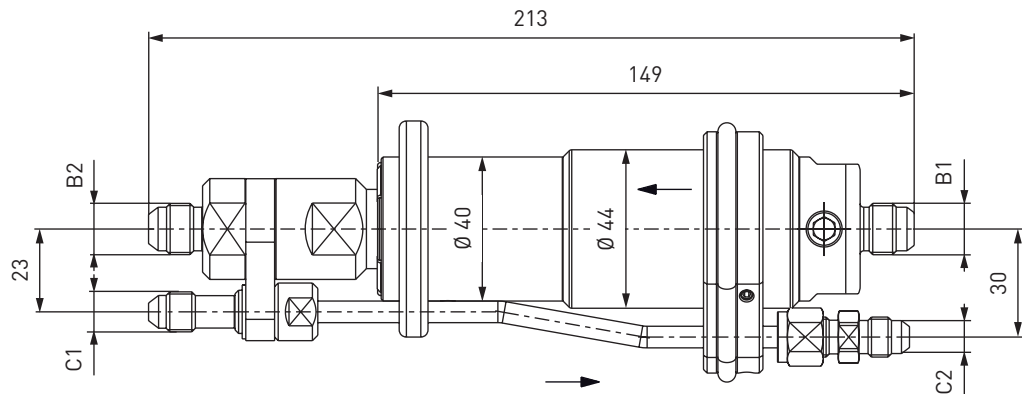

Part No.	Description	TNW	Pressure (MAWP)	B1/B2 (male thread)	C1/C2 (male thread)
C1-77240-X01	TSA2 H ₂	7 mm	45 MPa	UNF 9/16"-18*	UNF 7/16"-20*

* acc. to SAE J514, 37° cone

» Inline breakaway coupling TSA2 H₂

ACCESSORIES

The following accessories are available for the WEH[®] TSA2 H₂ Inline breakaway coupling:

WEH[®] TSF2 H₂ Filter

When using a TSA2 H₂ inline breakaway coupling, we additionally recommend the WEH[®] TSF2 H₂ Filter (see page 114). The filter protects the breakaway coupling and fueling nozzle from dirt ingress. The TSF2 H₂ is installed as a prefilter in the media inlet between the inline breakaway coupling and the filling hose.

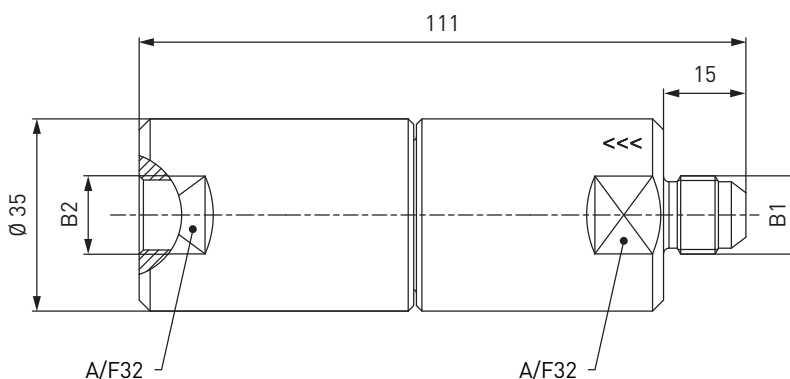

Part No.	Description	Filter (µm)	TNW	Pressure (MAWP)	B1 (male thread)	B2 (female thread)
C1-134710-X01	TSF2 H ₂	40	8 mm	45 MPa	UNF 9/16"-18*	UNF 9/16"-18*
C1-134711-X01	TSF2 H ₂	20	8 mm	45 MPa	UNF 9/16"-18*	UNF 9/16"-18*

* acc. to SAE J514, 37° cone

Hoses

Suitable hoses for the TSA2 H₂ inline breakaway coupling are available on request.

» Inline breakaway coupling TSA2 H₂

SPARE PARTS

Various parts are available as spares for the WEH® TSA2 H₂ Inline breakaway coupling.

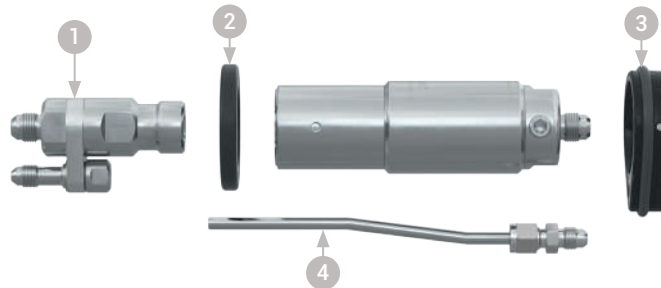

Part No.	Description
W94249	① Receptacle insert for TSA2 H ₂
B200B-119056	Spare seals set for receptacle insert W94249
E80-71324	② Front rubber protection
W150599	③ Mounting flange incl. impact protection
W139030	④ Spare part sets consisting of a gas recirculation tube and a firmly mounted fitting

» Fueling nozzle TK25 H₂

DESCRIPTION



Features

- Type A nozzle acc. to SAE J2600 resp. ISO 17268
- Compatible with WEH[®] TN5 H₂ receptacle profile
- Safe handling due to special safety function when disconnecting
- High flow rate → short filling times
- Recirculation of the vented gas
- Plastic thermal protection
- WEH[®] Jaw locking mechanism
- High-grade materials
- Coding for pressure range / gas type (acc. to table below)

The WEH[®] TK25 H₂ Fueling nozzle enables easy refueling of buses and trucks. Simply place the TK25 H₂ fueling nozzle onto the receptacle, turn the operating lever by 180° and the vehicle is refueled.

The internal coding for pressure range and gas type ensures that the WEH[®] TK25 H₂ can be connected to the compatible WEH[®] Receptacles acc. to the opposite table and also prevents the risk of confusion with natural gas.

The WEH[®] TK25 H₂ offers optimum safety for the operator. The fueling nozzle remains connected to the receptacle until the gas between inlet valve and receptacle is depressurized.

		TN5 H ₂	
		25 MPa	35 MPa
TK25 H ₂	25 MPa		
	35 MPa		✔

Application

Fueling nozzle for hydrogen fast filling of buses and trucks at self-service fueling stations.

TECHNICAL DATA

Characteristics	Basic version
Technical nominal size (TNW)	12 mm
Nominal Pressure	PN = 35 MPa
Max. allowable operating Pressure	MAWP = 45 MPa (PS = 450 bar)
Media temperature range	-20°C up to +85°C
Ambient temperature range	-40°C up to +85°C
Material	Corrosion resistant
Sealing material	Hydrogen resistant
Nozzle type	Type A acc. to SAE J2600:2015 and previous resp. ISO 17268:2012 and previous
Design	With plastic thermal protection and gas recirculation
Weight	Approx. 4.6 kg

Other designs on request

» Fueling nozzle TK25 H₂

ORDERING | WEH® TK25 H₂ Fueling nozzle

approx. dimensions (mm)

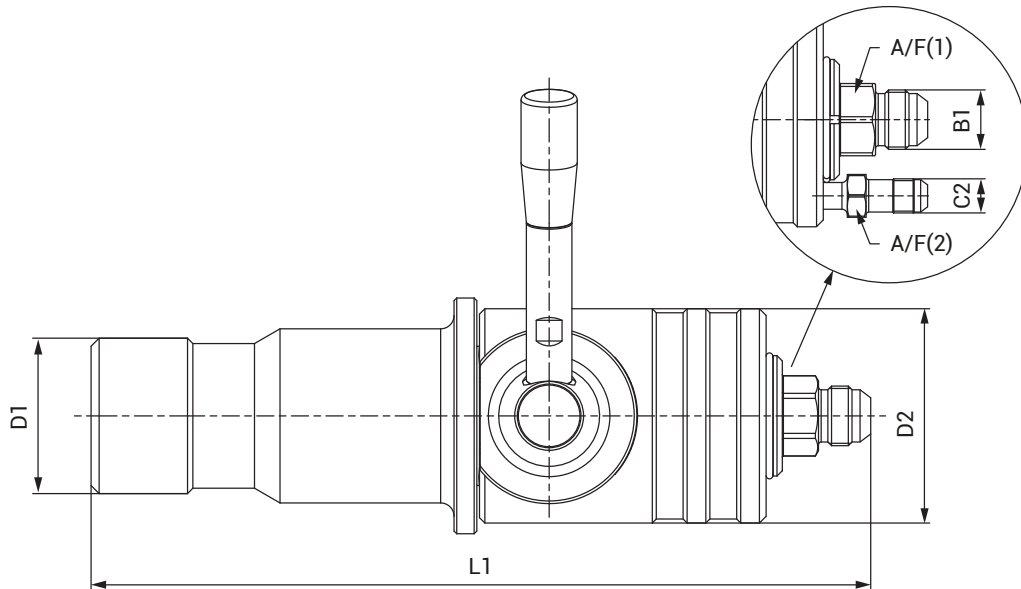

Part No.	Description	Pressure (MAWP)	B1 (male thread)	C2 (male thread)	L1	D1	D2	A/F(1)	A/F(2)
C1-62527-X1-X01	TK25 H ₂	45 MPa	UNF 7/8"-14*	UNF 9/16"-18*	305	58	80	27	16

* acc. to SAE J514, 37° cone

Fueling assemblies consisting of fueling nozzle, hose set and breakaway coupling are available on request.

ACCESSORIES

The following accessories are available for the WEH® TK25 H₂ Fueling nozzle:

Hose set

Hose set for connecting fueling nozzle and TSA5 H₂ breakaway coupling, complete with filling and venting hose, fittings and press-fittings supported by coil spring stubs. Not suitable for refueling with pre-cooled hydrogen acc. to SAE J2601.

Design filling/venting hose: max. operating pressure PS: 45 MPa / nominal bore for fitting: 5.6 mm (filling hose)
resp. 4.5 mm (venting hose) / media temperature range: -20°C up to +90°C



Part No.	B1/B2 (female thread)	C1/C2 (female thread)	Hose length
C1-152556	UNF 7/8"-14*	UNF 9/16"-18*	3 m
C1-152557	UNF 7/8"-14*	UNF 9/16"-18*	4 m
C1-152558	UNF 7/8"-14*	UNF 9/16"-18*	5 m

* acc. to SAE JIC, 37° cone

» Fueling nozzle TK25 H₂

Dispenser mounting

Mounting for safe attachment of the fueling nozzle to the dispenser.

Switch actuated dispenser mounting

approx. dimensions (mm)

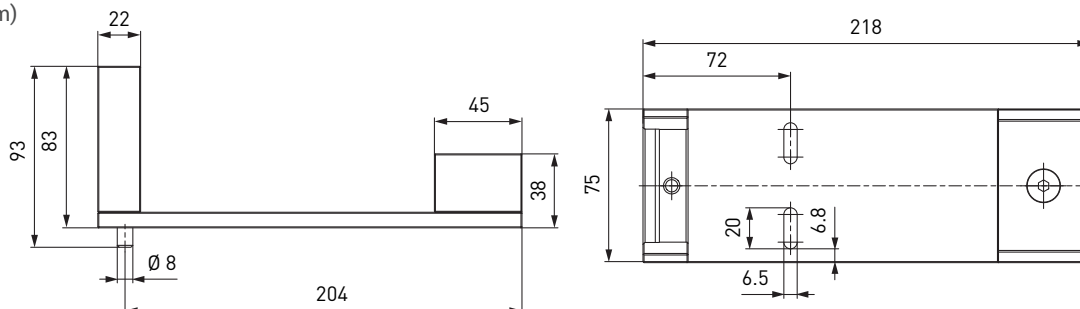

Switch actuated dispenser mounting with weather protection

approx. dimensions (mm)

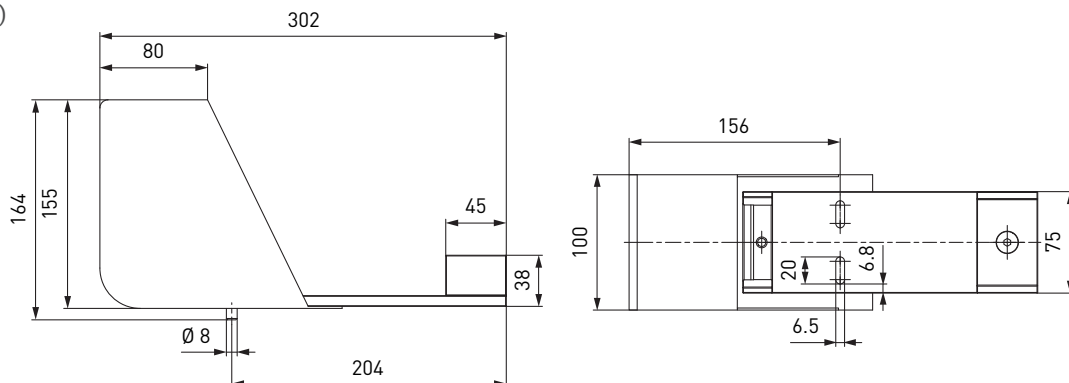

Part No.	Description
C1-83005	Dispenser mounting (switch actuated)
C1-82153	Dispenser mounting (switch actuated) and weather protection

WEH® TNS5 H₂ Service receptacle

To prevent damage in the fueling nozzle while leak testing during maintenance in the course of which pressure is applied, we recommend the use of a service receptacle. The receptacle also protects the fueling nozzle from dirt ingress whilst not in use.



Part no.	Description
C1-157347	TNS5 H ₂ Service receptacle incl. protection cap

WEH® Breakaway couplings

For the suitable TSA5 H₂ breakaway coupling or TSA6 H₂ inline breakaway coupling, please see page 86 resp. 90.

» Fueling nozzle TK25 H₂

SPARE PARTS

Various parts are available as spares for the WEH® TK25 H₂ Fueling nozzle.

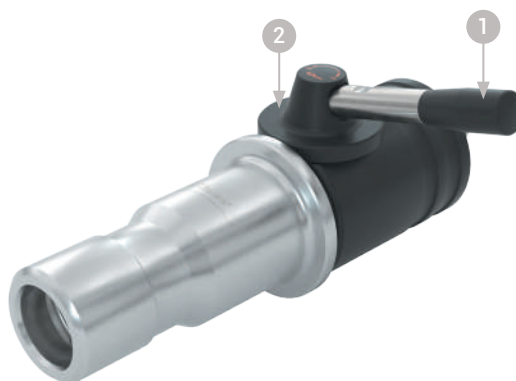

Part No.	Description
W6631	1 Actuation lever
E80-397S401	2 Cover plate
On request	Maintenance spray

» Breakaway coupling TSA5 H₂

DESCRIPTION

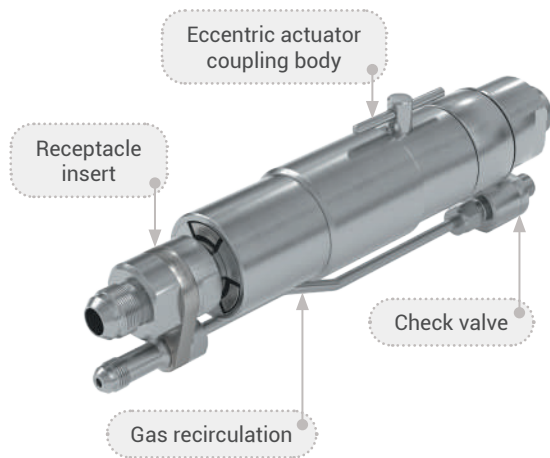

Features

- Reusable without factory servicing
- Installation at the dispenser
- Small compact design
- Integrated cleanable filter (40 µm)
- Check valve at venting line
- No additional tool necessary

The WEH[®] TSA5 H₂ Breakaway coupling provides additional safety for your bus and truck fueling station. The breakaway is installed between the dispenser and the filling/venting hose.

In the event of unexpected tensile forces, e.g. a vehicle driving away with a connected fueling nozzle, the breakaway separates the connections between dispenser and hoses in a controlled manner while sealing both ends.

Damage to the vehicle's receptacle, the fueling nozzle and the dispenser can thus be prevented as far as possible. The breakaway coupling can be reused after a functional test.

The integrated filter cleans the hydrogen from dirt ingress and can be cleaned easily and quickly during maintenance.

The WEH[®] Breakaway coupling consists of a coupling body, a receptacle insert and a gas recirculation with check valve.

On request we also offer fueling assemblies consisting of fueling nozzle, hose set and breakaway coupling.

Application

Breakaway coupling for bus and truck hydrogen fueling stations for direct installation at the dispenser.

TECHNICAL DATA

Characteristics	Basic version
Technical nominal size (TNW)	12 mm
Nominal Pressure	PN = 35 MPa
Max. allowable operating Pressure	MAWP = 45 MPa (PS = 450 bar)
Media temperature range	-20°C up to +85°C
Ambient temperature range	-40°C up to +85°C
Breakaway force	222 - 667 N
Material	Corrosion resistant stainless steel, aluminum
Sealing material	Hydrogen resistant
Design	With gas recirculation and filter (40 µm)

Other designs on request

» Breakaway coupling TSA5 H₂

ORDERING | WEH® TSA5 H₂ Breakaway coupling for TK25 H₂

approx. dimensions (mm)

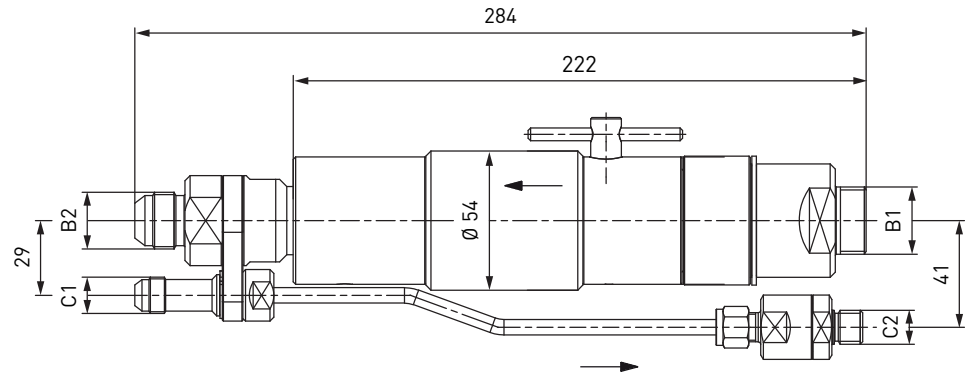

Part No.	Description	TNW	Pressure (MAWP)	B1 (male thread)	B2 (male thread)	C1 (male thread)	C2 (male thread)
C1-17941-X7-X01	TSA5 H ₂ with filter (40 µm)	12 mm	45 MPa	G3/4"	UNF 7/8"-14**	UNF 9/16"-18**	G1/4"

* acc. to DIN EN ISO 228-1

** acc. to SAE J514, 37° cone

» Breakaway coupling TSA5 H₂

ACCESSORIES

The following accessories are available for the WEH® TSA5 H₂ Breakaway coupling:

Dispenser mounting

The breakaway coupling can also be used with a dispenser mounting. The mounting is firmly attached to the dispenser. The integrated guide tube provides a straight pull-off force.

approx. dimensions (mm)

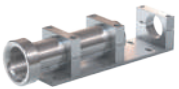
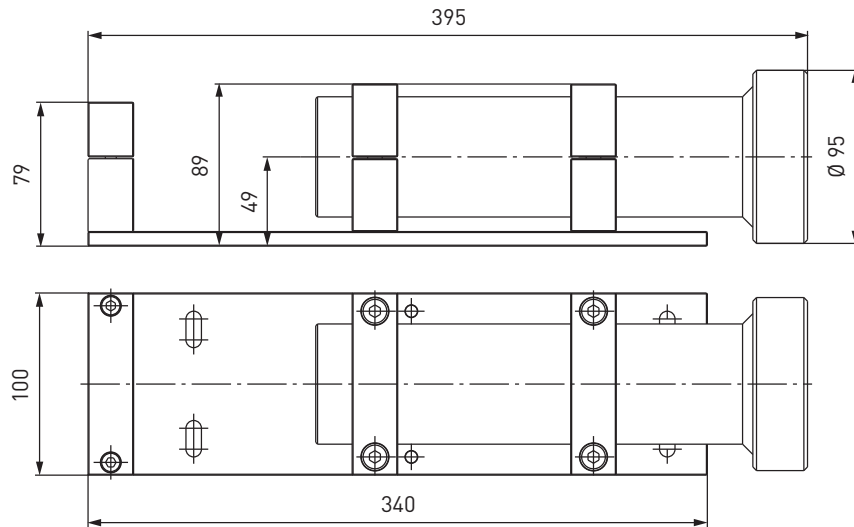

Part No.	Description
C1-82110	Dispenser mounting for TSA5 H ₂

Hoses

Suitable hoses for the TSA5 H₂ breakaway coupling are available on request.

» Breakaway coupling TSA5 H₂

SPARE PARTS

Various parts are available as spares for the WEH® TSA5 H₂ Breakaway coupling.

Part No.	Description
W83706	Receptacle insert for TSA5 H ₂
B200B-119726	Spare seals set for receptacle insert W83706
W139034	Spare parts set consisting of a gas recirculation tube (length: approx. 195 mm) and a firmly mounted check valve
W9062	Wire filter insert 40 µm

» Inline breakaway coupling TSA6 H₂

DESCRIPTION

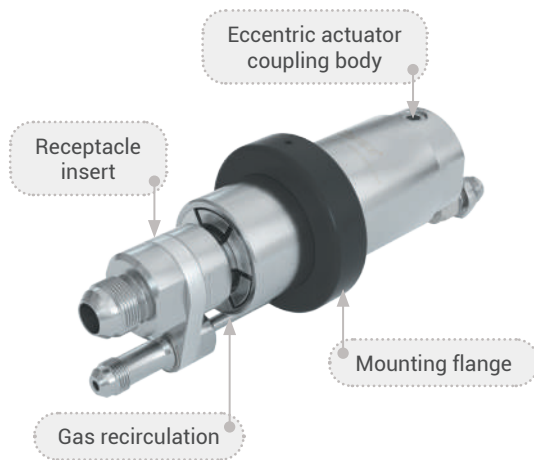

Features

- Reusable without factory servicing
- Installation between the filling and venting hoses
- Small compact design
- Mounting flange
- Eccentric actuation via Allen wrench

With the WEH[®] TSA6 H₂ Breakaway coupling, an inline breakaway coupling is also available for bus and truck refueling stations which is installed between the filling and venting hoses.

In the event of unexpected tensile forces, e.g. a vehicle driving away with a connected fueling nozzle, the breakaway separates the connections between dispenser and hoses in a controlled manner while sealing both ends. Damage to the vehicle's receptacle, the fueling nozzle and the dispenser can thus be prevented as far as possible. The breakaway coupling can be reused after a functional test.

The WEH[®] Breakaway coupling consists of a coupling body, a receptacle insert and a gas recirculation.

On request we also offer fueling assemblies consisting of fueling nozzle, hose set and inline breakaway coupling.

Application

Inline breakaway coupling for bus and truck hydrogen fueling stations for installation between the filling and venting hoses.

TECHNICAL DATA

Characteristics	Basic version
Technical nominal size (TNW)	12 mm
Nominal Pressure	PN = 35 MPa
Max. allowable operating Pressure	MAWP = 45 MPa (PS = 450 bar)
Media temperature range	-20°C up to +85°C
Ambient temperature range	-40°C up to +85°C
Breakaway force	222 - 667 N
Material	Corrosion resistant stainless steel, aluminum
Sealing material	Hydrogen resistant
Design	With gas recirculation

Other designs on request

» Inline breakaway coupling TSA6 H₂

ORDERING | WEH® TSA6 H₂ Inline breakaway coupling for TK25 H₂

approx. dimensions (mm)

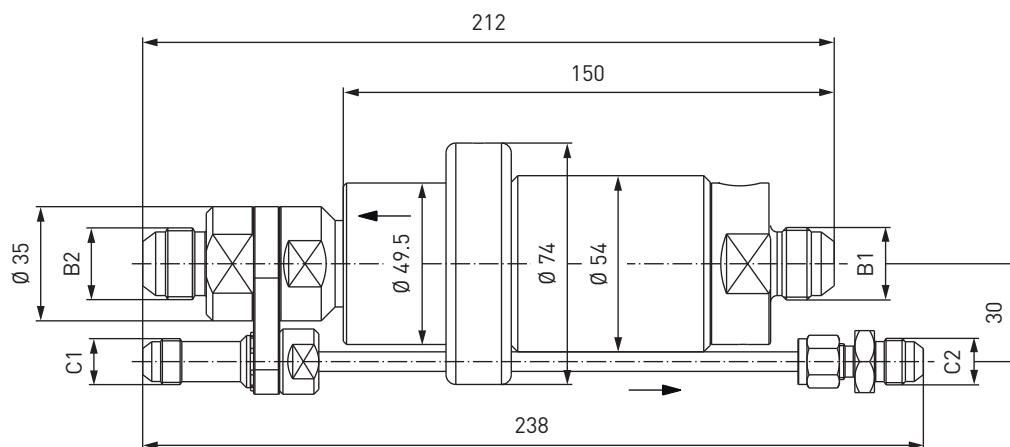

Part No.	Description	TNW	Pressure (MAWP)	B1/B2 (male thread)	C1/C2 (male thread)
C1-82323-X01	TSA6 H ₂	12 mm	45 MPa	UNF 7/8"-14*	UNF 9/16"-18*

* acc. to SAE J514, 37° cone

ACCESSORIES

The following accessories are available for the WEH® TSA6 H₂ Inline breakaway coupling:

Hoses

Suitable hoses for the TSA6 H₂ inline breakaway coupling are available on request.

SPARE PARTS

Various parts are available as spares for the WEH® TSA6 H₂ Inline breakaway coupling.

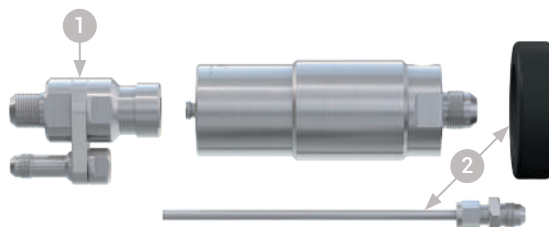

Part No.	Description
W83706	1 Receptacle insert for TSA6 H ₂
B200B-119726	Spare seals set for receptacle insert W83706
W139031	2 Spare parts set consisting of a mounting flange, a gas recirculation tube and a firmly mounted fitting

» Receptacle TN9-S2 H₂ 35 MPa



DESCRIPTION



Features

- **High flow rate of up to 90 g/s** for fast refueling
- **10-µm metal wire mesh filter**, customizable
- Based on TN9-S1 H₂ 70 MPa tested in accordance with ISO 17268:2020
- Low-noise refueling thanks to optimized inner shape
- Seal-friendly design: Robust, durable and easy to maintain
- Coding for pressure range / gas type (acc. to table below)

The WEH® TN9-S2 H₂ 35 MPa receptacle was specially developed for refueling road vehicles with hydrogen in the 350 bar pressure range.

The aerodynamically optimized inner shape of the receptacle ensures a virtually silent filling process and guarantees a maximum flow rate of up to 90 g/s. The seal-friendly design effectively protects internal seals from damage and ensures a long service life.

Thanks to its robustness and minimal maintenance requirements, the TN9-S2 H₂ 35 MPa is particularly reliable and helps to reduce downtimes. It is also equipped with an integrated check valve and complies with the H70 version tested in accordance with ISO 17268:2020.

More safety thanks to integrated self-cleaning particle filter

The integrated filter cartridge with a pore size of 10µm, custom-made for the TN9, offers reliable protection against dirt particles and impurities. Its multi-layer wire mesh enables outstanding filter performance by effectively removing even long fibers and the smallest particles. This filter not only prevents leaks at the receptacle, but also ensures that operation remains safe and reliable even under difficult environmental conditions. The filter can also be flexibly adapted to different degrees of purity to meet your specific requirements.

		TK H ₂ (Except TK25 H ₂)				
		25 MPa	35 MPa	35 MPa MF*	35 MPa HF**	70 MPa
TN9-S2 H ₂ 35 MPa	35 MPa	✓	✓			
	35 MPa					

*MF = Medium-Flow acc. to ISO 17268-1:2025
**HF = High-Flow acc. to ISO 17268:2012

Application

Receptacle for hydrogen refueling / filling of road vehicles and for industrial applications suitable for WEH® fueling nozzles according to the table above.

TECHNICAL DATA

Characteristics	Basic version
Nominal pressure	PN = 35 MPa
Max. allowable operating pressure	MOP = 43.75 MPa (PS = 437.5 bar)
Temperature range	-40°C up to +85°C
Material	Corrosion resistant
Sealing material	Hydrogen resistant
Design	With protection cap, integrated particle filter and integrated check valve
Coding	H35 Grade D gemäß ISO 17268-1:2025
Conformity / Tests / Approvals	TN9-S2 H ₂ 35 MPa is based on TN9-S1 H ₂ 70 MPa, tested in accordance with ISO 17268:2020.

Other designs on request

» Receptacle TN9-S2 H₂ 35 MPa

DESCRIPTION | WEH® TN9-S2 H₂ 35 MPa Receptacle with double ferrule fitting

approx. dimensions (mm)

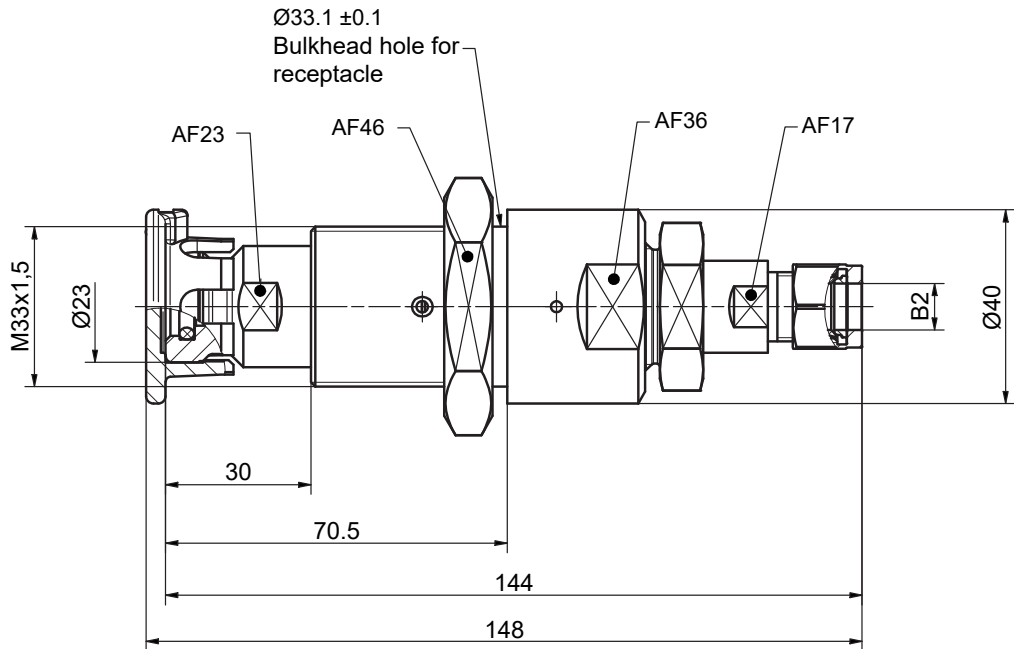

Part No.	Description	Mesh size filter	Pressure (MOP)	B2
C1-189885	TN9-S2 H ₂ 35 MPa	10 µm	43.75 MPa	Tube Ø3/8"*

*double ferrule fitting

» Receptacle TN9-S2 H₂ 35 MPa

ACCESSORIES

The following accessories are available for the WEH[®] TN9-S2 H₂ 35 MPa Receptacle:

Infrared data interface incl. holder for TN9

Application example:

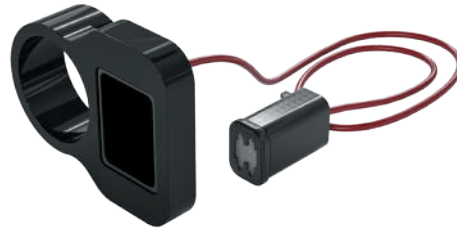

Part No.	Description
C1-188500	Infrared data interface incl. holder for TN9 (Input signal RS485, output signal J2799 Infrared)
C1-188941	Mounting nut (for IR interface)

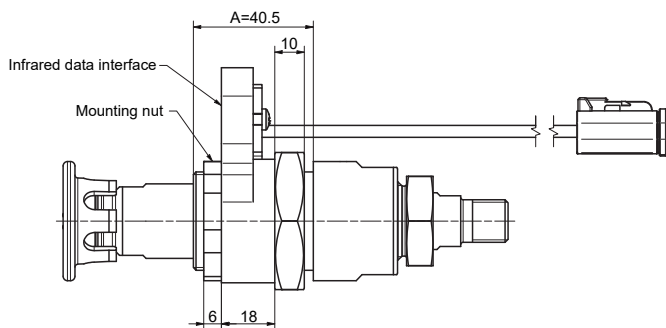

Note: The WEH[®] receptacle is designed to accommodate an attached data interface in area "A."
When installing the WEH[®] receptacle, ensure that the permissible installation space A of 40.5 mm is not exceeded.

Take into account the sheet thickness, nut height, and data interface, including the mounting element.

When using data interface C1-188500 and mounting nut C1-188941, the sheet metal thickness must not exceed 6 mm.

» Receptacle TN9-S2 H₂ 35 MPa

SPARE PARTS

Various parts are available as spares for the WEH[®] TN9-S2 H₂ 35 MPa Receptacle.

Protection cap / Nut

Protection cap with a strap to protect the receptacle from dirt ingress.



Part No.	Description
W85984	Protection cap for receptacles
C1-185122	TN9 Nut M33x1.5 for receptacle mounting

» Receptacle TN9-S3 H₂ 35 MPa Medium-Flow



DESCRIPTION



Features

- High flow rate of up to 120 g/s for fast refueling
- 10- μ m metal wire mesh filter, customizable
- Based on TN9-S1 H₂ 70 MPa tested in accordance with ISO 17268:2020
- Low-noise refueling thanks to optimized inner shape
- Seal-friendly design: Robust, durable and easy to maintain
- Coding for pressure range / gas type (acc. to table below)

The WEH[®] TN9-S3 H₂ 35 MPa Medium-Flow receptacle was specially developed for refueling road vehicles with hydrogen in the 350 bar pressure range.

The aerodynamically optimized inner shape of the receptacle ensures a virtually silent filling process and guarantees a maximum flow rate of up to 120 g/s. The seal-friendly design effectively protects internal seals from damage and ensures a long service life.

Thanks to its robustness and minimal maintenance requirements, the TN9-S3 H₂ 35 MPa Medium-Flow is particularly reliable and helps to reduce downtimes. It is also equipped with an integrated check valve and complies with the H70 version tested in accordance with ISO 17268:2020.

More safety thanks to integrated self-cleaning particle filter

The integrated filter cartridge with a pore size of 10 μ m, custom-made for the TN9, offers reliable protection against dirt particles and impurities. Its multi-layer wire mesh enables outstanding filter performance by effectively removing even long fibers and the smallest particles. This filter not only prevents leaks at the receptacle, but also ensures that operation remains safe and reliable even under difficult environmental conditions. The filter can also be flexibly adapted to different degrees of purity to meet your specific requirements.

Application

Receptacle for hydrogen refueling / filling of road vehicles and for industrial applications suitable for WEH[®] fueling nozzles according to the table above.

		TK H ₂ (Except TK25 H ₂)				
		25 MPa	35 MPa	35 MPa MF*	35 MPa HF**	70 MPa
TN9-S3 H ₂ 35 MPa Medium-Flow	35 MPa	✓	✓	✓	✓	

*MF = Medium-Flow acc. to ISO 17268-1:2025

**HF = High-Flow acc. to ISO 17268:2012

TECHNICAL DATA

Characteristics	Basic version
Nominal pressure	PN = 35 MPa
Max. allowable operating pressure	MOP = 43.75 MPa (PS = 437.5 bar)
Temperature range	-40°C up to +85°C
Material	Corrosion resistant
Sealing material	Hydrogen resistant
Design	With protection cap, integrated particle filter and integrated check valve
Coding	H35MF Grade D gemäß ISO 17268-1:2025
Conformity / Tests / Approvals	TN9-S3 H ₂ 35 MPa MF is based on TN9-S1 H ₂ 70 MPa, tested in accordance with ISO 17268:2020.

Other designs on request

» Receptacle TN9-S3 H₂ 35 MPa Medium-Flow

DESCRIPTION | WEH® TN9-S3 H₂ 35 MPa Medium-Flow Receptacle with double ferrule fitting
approx. dimensions (mm)

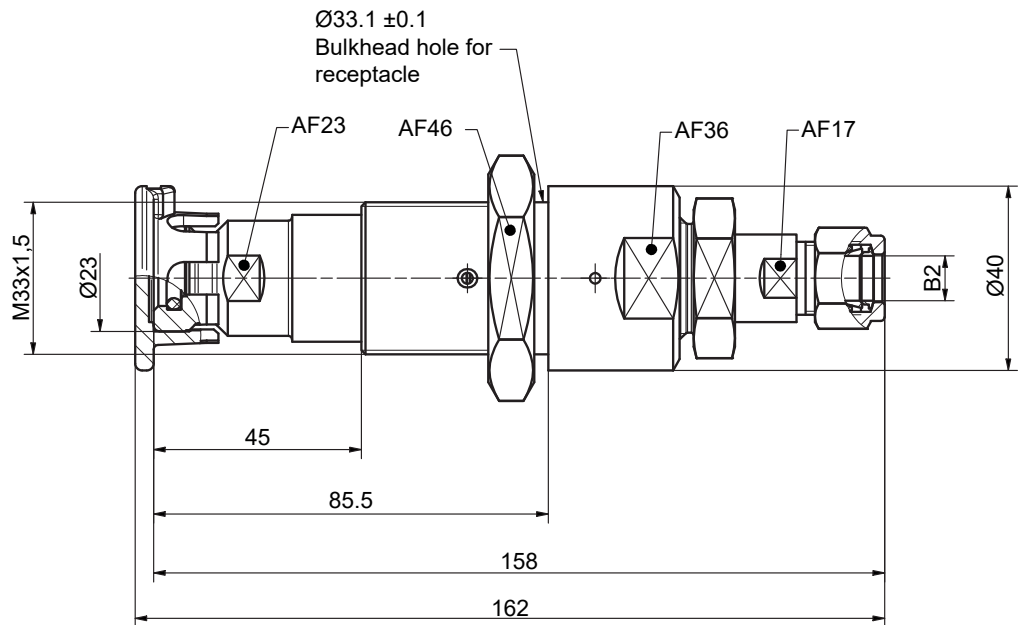

Part No.	Description	Mesh size filter	Pressure (MOP)	B2
C1-189887	TN9-S3 H ₂ 35 MPa Medium-Flow	10 µm	43.75 MPa	Tube Ø10 mm*

*double ferrule fitting

» Receptacle TN9-S3 H₂ 35 MPa Medium-Flow

ACCESSORIES

The following accessories are available for the WEH® TN9-S3 H₂ 35 MPa Medium-Flow Receptacle:

Infrared data interface incl. holder for TN9

Application example:

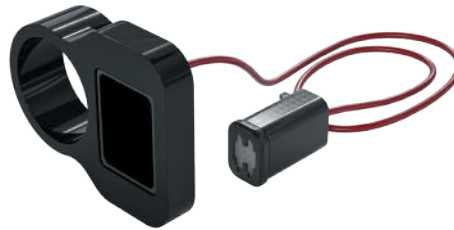

Part No.	Description
C1-188500	Infrared data interface incl. holder for TN9 (Input signal RS485, output signal J2799 Infrared)
C1-188941	Mounting nut (for IR interface)

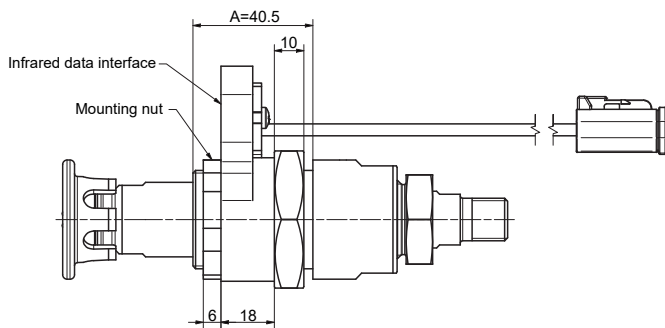

Note: The WEH® receptacle is designed to accommodate an attached data interface in area "A." When installing the WEH® receptacle, ensure that the permissible installation space A of 40.5 mm is not exceeded.

Take into account the sheet thickness, nut height, and data interface, including the mounting element.

When using data interface C1-188500 and mounting nut C1-188941, the sheet metal thickness must not exceed 6 mm.

» Receptacle TN9-S3 H₂ 35 MPa Medium-Flow

SPARE PARTS

Various parts are available as spares for the WEH[®] TN9-S3 H₂ 35 MPa Medium-Flow Receptacle.

Protection cap / Nut

Protection cap with a strap to protect the receptacle from dirt ingress.



Part No.	Description
W85984	Protection cap for receptacles
C1-185122	TN9 Nut M33x1.5 for receptacle mounting

» Receptacle TN1 H₂

DESCRIPTION



Features

- Low-noise refueling
- Version with and without integrated self-cleaning particle filter (40 µm or 50 µm)
- Integrated high-flow check valve
- Sealing-friendly design
- Coding for pressure range / gas type (acc. to table below)

The WEH[®] TN1 H₂ Receptacle was specially designed for refueling cars with hydrogen.

Due to the aerodynamic design of the internal shapes of the receptacle, noise during refueling process is mostly eliminated, while at the same time maximum flow rate is enabled. The internal seals are arranged to largely prevent damage to the sealing components. That is why the WEH[®] TN1 H₂ proves to be extremely robust and durable, minimizing downtimes due to low maintenance.

The receptacle is equipped with an integrated check valve and has a coding for pressure range / gas type.

Enhanced safety by integrated particle filter

The use of an integrated particle filter prevents the ingress of dirt particles from the outside and therefore leakage at the receptacle is almost eliminated.

Application

Receptacle for hydrogen refueling / filling of cars and fork-lift trucks or other industrial applications, to be used with WEH[®] Fueling nozzles acc. to opposite table.

		TK H ₂ (Except TK25 H ₂)				
		25 MPa	35 MPa	35 MPa MF*	35 MPa HF**	70 MPa
TN1 H ₂	25 MPa	✓				
	35 MPa	✓	✓			

*MF = Medium-Flow acc. to ISO 17268-1:2025

**HF = High-Flow acc. to ISO 17268:2012

TECHNICAL DATA

Characteristics	Basic version
Technical nominal size (TNW)	Depending on design
Nominal Pressure	PN = 25 MPa, 35 MPa
Max. allowable operating Pressure	PS = 35 MPa, 45 MPa
Temperature range	-40°C up to +85°C
Material	Corrosion resistant
Sealing material	Hydrogen resistant
Coding	Depending on design
Design	With protection cap, with integrated particle filter (40 µm or 50 µm), integrated check valve and fittings (only for receptacles with tube fitting)
Conformity / Tests / Approvals	<div style="border: 1px solid black; padding: 2px; display: inline-block;">e 1</div> 00 0008 (Regulation (EC) No. 79/2009) Leak tests acc. to SAE J2600:2002 GB/T 26779-2021 (only applies to EC79 articles)

Other designs on request

» Receptacle TN1 H₂

ORDERING | WEH® TN1 H₂ Receptacle with tube fitting and filter (50 µm)

approx. dimensions (mm)

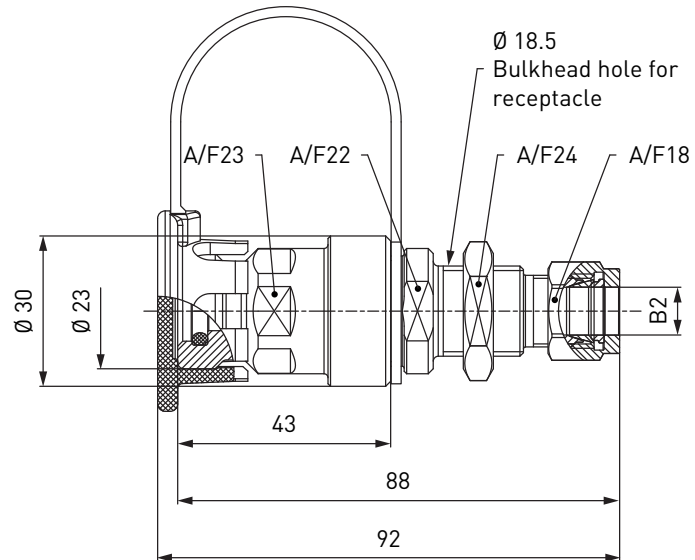

Part No.	Description	Coding	TNW	Pressure (MAWP)	B2
C1-31315-X1-X01	TN1 H ₂	H25 acc. to ISO 17268:2012	8 mm	PS = 35 MPa	Tube Ø 3/8**
C1-31316-X1	TN1 H ₂ (EC79)	H35 Grade D acc. to ISO 17268-1:2025	8 mm	MAWP = 45 MPa	Tube Ø 3/8**
C1-70661-X01	TN1 H ₂	H25 acc. to ISO 17268:2012	8 mm	PS = 35 MPa	Tube Ø 10*
C1-35426-X2	TN1 H ₂ (EC79)	H35 Grade D acc. to ISO 17268-1:2025	8 mm	MAWP = 45 MPa	Tube Ø 10*

* double ferrule fitting

» Receptacle TN1 H₂

ORDERING | WEH® TN1 H₂ Receptacle prepared for data interface, with filter (40 µm)

approx. dimensions (mm)

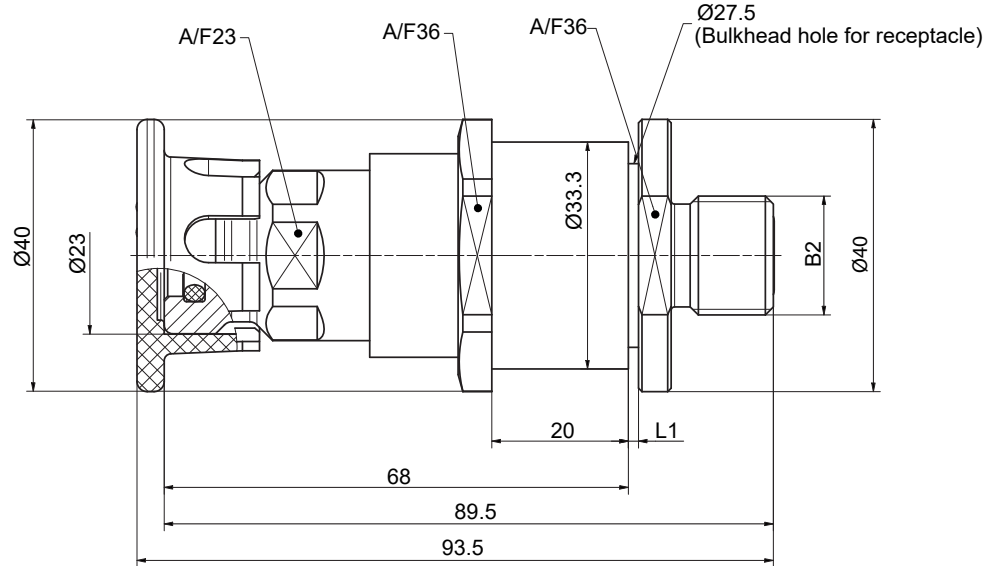

Part No.	Description	Coding	TNW	Pressure (MAWP)	L1	B2 (male thread)
C1-172510	TN1 H ₂ (EC79)	H35 Grade D acc. to ISO 17268-1:2025	6 mm	45 MPa	1.5**	UN 11/16"-16 for sealing with O-Lok® Face Seal* or tube $\varnothing 10$ (3/8")

* Face Seal acc. to SAE J1453

** Please indicate when ordering if thicker sheet metals are needed!
Data interface not included!

Other connection sizes and types (e.g. Cone and Thread Fittings or VOSSLok⁴⁰) on request.

» Receptacle TN1 H₂

SPARE PARTS

Various parts are available as spares for the WEH[®] TN1 H₂ Receptacle.

Protection cap

Protection cap with a strap to protect the receptacle from dirt ingress.

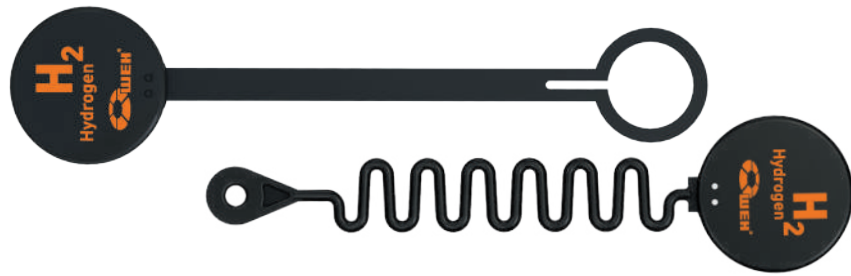

Part No.	Description
W87803	Protection cap
W85984	Protection cap for receptacles prepared for data interface

» Receptacle TN1 H₂ Medium-Flow

DESCRIPTION



Features

- Low-noise refueling
- Integrated self-cleaning particle filter (40 µm)
- Integrated high-flow check valve
- Sealing-friendly design
- Coding for pressure range / gas type (acc. to table below)

The WEH[®] TN1 H₂ Medium-Flow Receptacle was developed for higher flow requirements. This enables buses and trucks to be refueled from now on at car fueling stations. Due to the aerodynamic design of the internal shapes of the receptacle, noise during refueling process is mostly eliminated, while at the same time maximum flow rate is enabled. The internal seals are arranged to largely prevent damage to the sealing components. That is why the WEH[®] TN1 H₂ Medium-Flow proves to be extremely robust and durable, minimizing downtimes due to low maintenance. The receptacle is equipped with an integrated check valve and has a coding for pressure range / gas type.

Enhanced safety by integrated particle filter

The use of an integrated particle filter prevents the ingress of dirt particles from the outside and therefore leakage at the receptacle is almost eliminated.

Application

Receptacle for hydrogen refueling / filling of buses, trucks and fork-lift trucks or other industrial applications, to be used with WEH[®] Fueling nozzles acc. to opposite table.

		TK17 H ₂ / TK16 H ₂				
		25 MPa	35 MPa	35 MPa MF*	35 MPa HF*	70 MPa
TN1 H ₂ MF*	35 MPa	✓	✓	✓	✓	

*MF = Medium-Flow acc. to ISO 17268-1:2025
 **HF = Medium-Flow acc. to ISO 17268:2012
 This coding table applies exclusively to the variants listed below (other variants on request).

TECHNICAL DATA

Characteristics	Basic version
Technical nominal size (TNW)	Depending on design
Nominal Pressure	PN = 35 MPa
Max. allowable operating Pressure	PS (MAWP) = 43.75 MPa
Temperature range	-40°C up to +85°C
Material	Corrosion resistant
Sealing material	Hydrogen resistant
Coding	Depending on design
Design	With protection cap, integrated particle filter (40 µm), integrated check valve and fittings (only for receptacles with tube fitting)
Conformity / Tests / Approvals	 00 0003 (Regulation (EC) No. 79/2009)

Other designs on request

» Receptacle TN1 H₂ Medium-Flow

ORDERING | WEH® TN1 H₂ Medium-Flow Receptacle with tube fitting

approx. dimensions (mm)

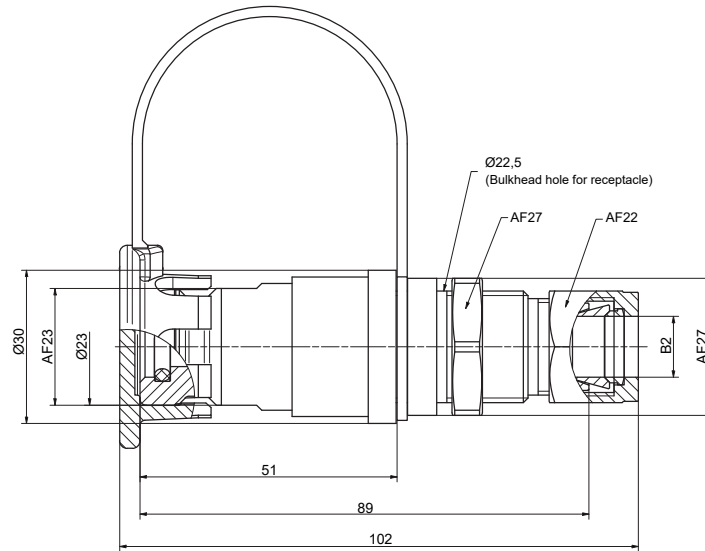

Part No.	Approval type	Coding	TNW	Pressure (MAWP)	B2
C1-187355	TN1-35HF (EC79)	H35Mf Grade D acc. to ISO 17268-1:2025	8 mm	43.75 MPa	Tube Ø 12*

* double ferrule fitting

» Receptacle TN1 H₂ Medium-Flow

ORDERING | WEH® TN1 H₂ Medium-Flow Receptacle with male thread, prepared for data interface

approx. dimensions (mm)

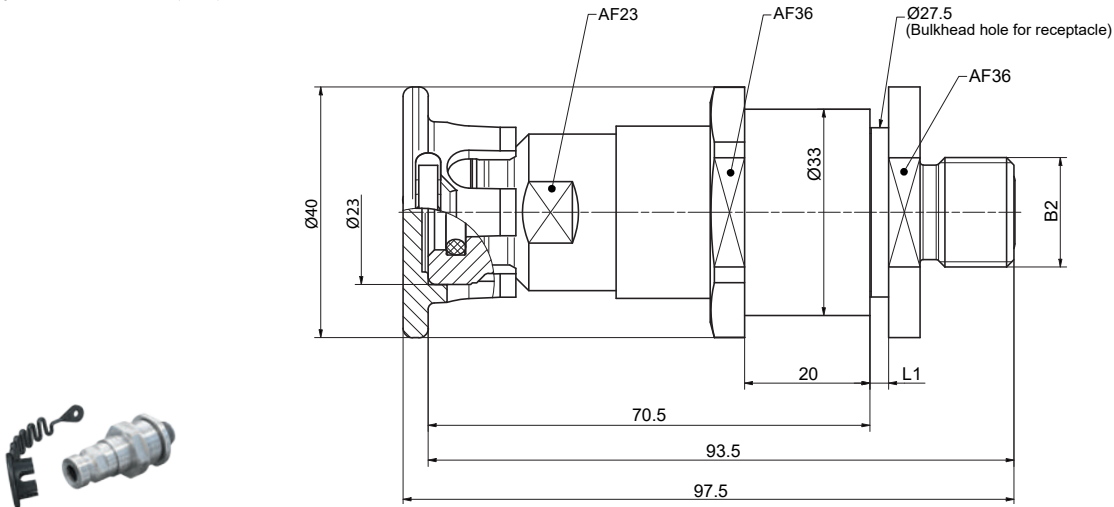

Part No.	Approval type	Coding	TNW	Pressure (MAWP)	L1	B2 (male thread)
C1-187534	TN1-35HF (EC79)	H35MF Grade D acc. to ISO 17268-1:2025	6 mm	43,75 MPa	2,5**	UN 11/16"-16 for sealing with O-Lok® Face Seal* for tube Ø 10 (3/8")

* Face Seal acc. to SAE J1453

** Please indicate when ordering if thicker sheet metals are needed!
Data interface not included!

ORDERING | WEH® TN1 H₂ Medium-Flow Receptacle with male thread, prepared for data interface

approx. dimensions (mm)

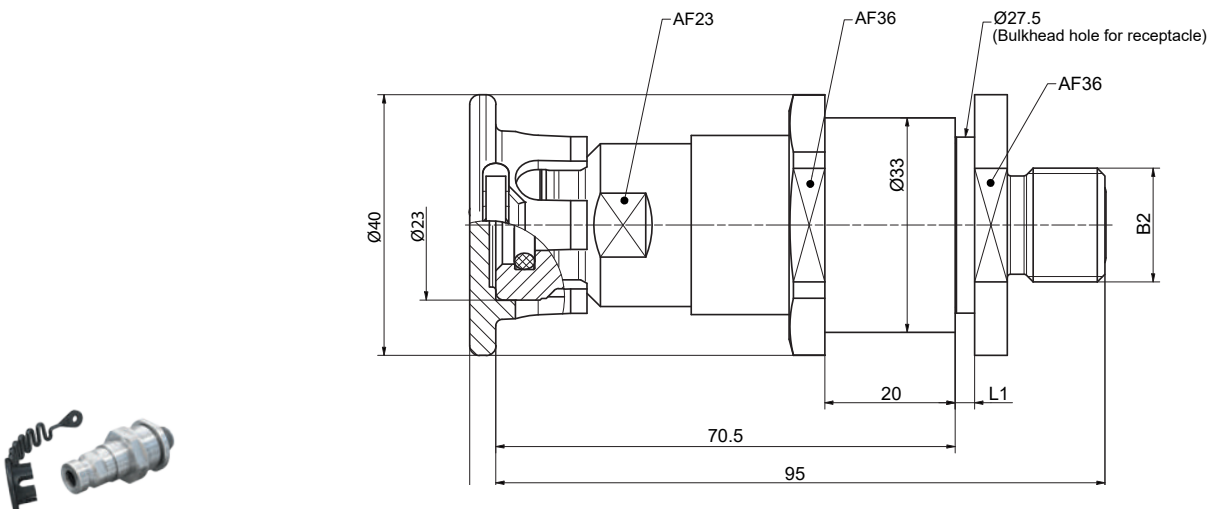

Part No.	Approval type	Coding	TNW	Pressure (MAWP)	L1	B2 (male thread)
C1-189047	TN1-35HF (EC79)	H35MF Grade D acc. to ISO 17268-1:2025	8 mm	43,75 MPa	2,5**	UN 13/16"-16 for sealing with O-Lok® Face Seal* for tube Ø 12.7 (1/2")

* Face Seal acc. to SAE J1453

** Please indicate when ordering if thicker sheet metals are needed!
Data interface not included!

» Receptacle TN1 H₂ Medium-Flow

ORDERING | WEH® TN1 H₂ Medium-Flow Receptacle with tube fitting, prepared for data interface

approx. dimensions (mm)

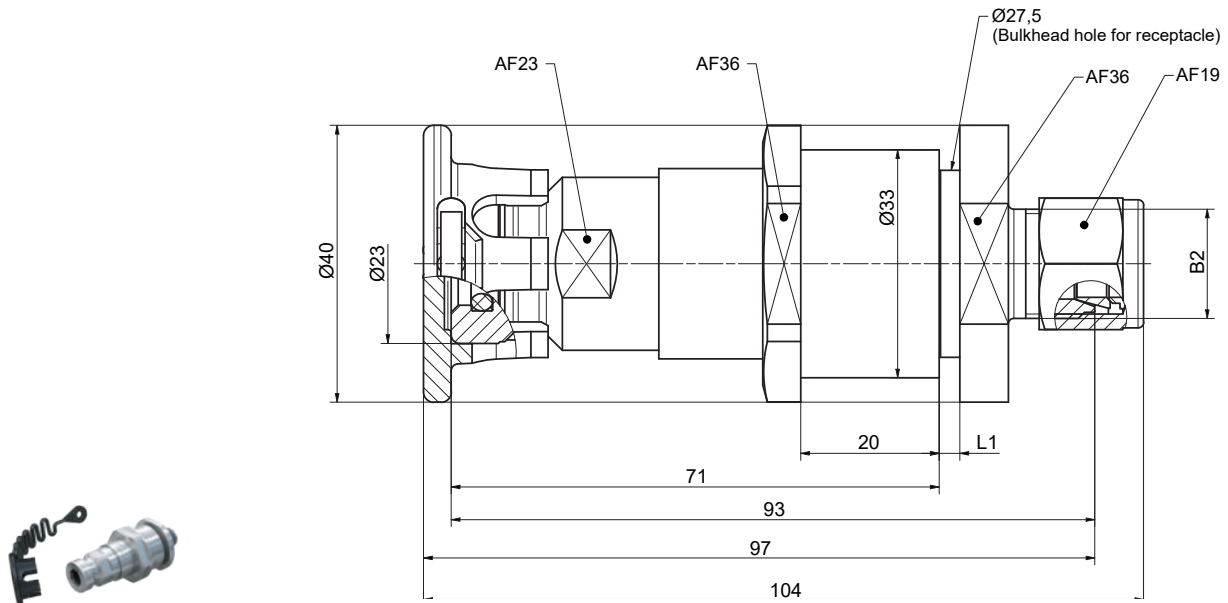

Part No.	Approval type	Coding	TNW	Pressure (MAWP)	L1	B2 (male thread)
C1-182091	TN1-35HF (EC79)	H35Mf Grade D acc. to ISO 17268-1:2025	8 mm	43.75 MPa	2.5**	Tube Ø 10*

* Face Seal acc. to SAE J1453

** Please indicate when ordering if thicker sheet metals are needed!

Data interface not included!

Other connection sizes and types (e.g. Cone and Thread Fittings or VOSSLok⁴⁰) on request.

SPARE PARTS

Various parts are available as spares for the WEH® TN1 H₂ Medium-Flow Receptacle.

Protection cap

Protection cap with a strap to protect the receptacle from dirt ingress.

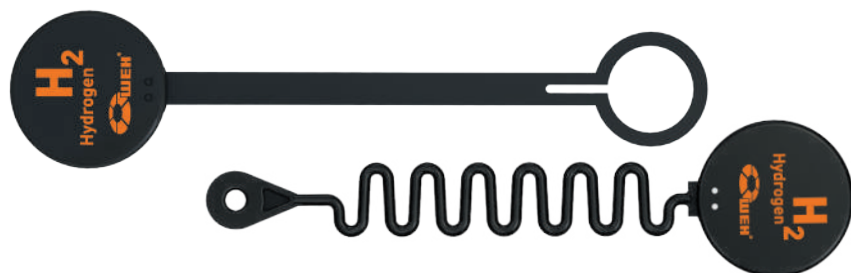

Part No.	Description
W87803	Protection cap
W85984	Protection cap for receptacles prepared for data interface

» Receptacle TN5 H₂

DESCRIPTION



Features

- Low-noise refueling
- Integrated self-cleaning particle filter (50 µm)
- Integrated high-flow check valve
- Sealing-friendly design
- Coding for pressure range / gas type (acc. to table below)

The WEH[®] TN5 H₂ Receptacle was specially designed for refueling buses and trucks with hydrogen. Due to the aerodynamic design of the internal shapes of the receptacle, noise during refueling process is mostly eliminated, while at the same time high flow rate is enabled. The internal seals are arranged to largely prevent damage to the sealing components. That is why the WEH[®] TN5 H₂ proves to be extremely robust and durable, minimizing downtimes due to low maintenance.

The receptacle is equipped with an integrated check valve and has a coding for pressure range / gas type.

Enhanced safety by integrated particle filter

The use of an integrated particle filter prevents the ingress of dirt particles from the outside and therefore leakage at the receptacle is almost eliminated.

Application

Receptacle for hydrogen refueling / filling of buses, trucks and fork-lift trucks or other industrial applications, to be used with WEH[®] TK25 H₂ Fueling nozzle.

		TK25 H ₂	
		25 MPa	35 MPa
TN5 H ₂	35 MPa	✔	✔

TECHNICAL DATA

Characteristics	Basic version
Technical nominal size (TNW)	Depending on design
Nominal Pressure	PN = 35 MPa
Max. allowable operating Pressure	PS (MAWP) = 45 MPa
Temperature range	-40°C up to +85°C
Material	Corrosion resistant
Sealing material	Hydrogen resistant
Design	With protection cap, integrated particle filter (50 µm), integrated check valve and fittings
Conformity / Tests / Approvals	GB/T 26779-2021

Other designs on request

» Receptacle TN5 H₂

ORDERING | WEH® TN5 H₂ Receptacle with tube fitting

approx. dimensions (mm)

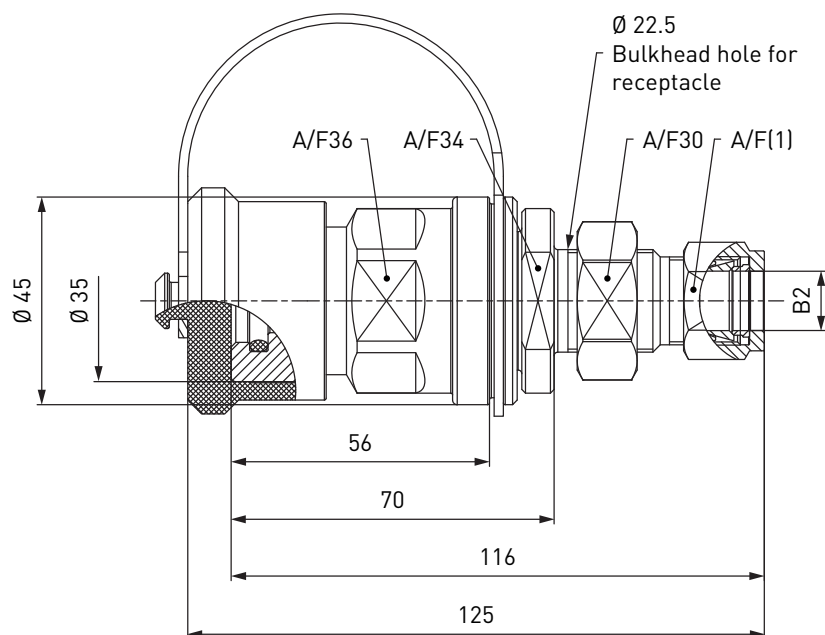

Part No.	Description	TNW	Pressure (MAWP)	B2	A/F(1)
C1-49772-X1-X01	TN5 H ₂	10.5 mm	45 MPa	Tube Ø 12 mm*	22
C1-174547	TN5 H ₂	10.5 mm	45 MPa	Tube Ø 1/2"	22
C1-19136-X1-X01	TN5 H ₂	12 mm	45 MPa	Tube Ø 16 mm*	25

* double ferrule fitting

Other connection sizes and types (e.g. Cone and Thread Fittings or VOSSLok⁴⁰) on request.

SPARE PARTS

Various parts are available as spares for the WEH® TN5 H₂ Receptacle.

Protection cap

Protection cap with a strap to protect the receptacle from dirt ingress.



Part No.	Description
E80-134306	Protection cap

» Check valve TVR1 H₂

DESCRIPTION



Features

- Robust construction
- Low-noise opening and closing
- Corrosion resistant stainless steel
- High leak tightness

With the TVR1 H₂ WEH offers a high-performance check valve for use with gaseous hydrogen. The WEH[®] TVR1 H₂ check valves provide a reliable function wherever hydrogen should only flow in one direction within a pipe system and must be prevented from a return flow.

The seals in the valve are arranged to prevent them from being damaged by dirt particles in the gas flow. The WEH[®] TVR1 H₂ Check valve is made of corrosion-resistant stainless steel achieving a very durable unit due to its robust internal structure.

Application

Check valve for cars, also suitable for installation in hydrogen fueling stations.

The WEH[®] TVR1 H₂ product family is offered as a return flow prevention acc. to DIN EN 736-1 for installation in H₂ systems and pipelines.

TECHNICAL DATA

Characteristics	Basic version
Technical nominal size (TNW)	8 mm
Nominal Pressure	PN = 35 MPa
Max. allowable operating Pressure	PS (MAWP) = 45 MPa
Temperature range	-40°C up to +85°C
Material	Corrosion resistant stainless steel (inner components partially made of brass: C1-18485/4)
Sealing material	Hydrogen resistant
Design	Incl. fittings (only for check valves with tube fitting) With integrated particle filter on request
Conformity / Tests / Approvals	 00 0005 (Regulation (EC) No. 79/2009)

Other designs on request

» Check valve TVR1 H₂

ORDERING | WEH® TVR1 H₂ Check valve with tube fitting on both sides

approx. dimensions (mm)

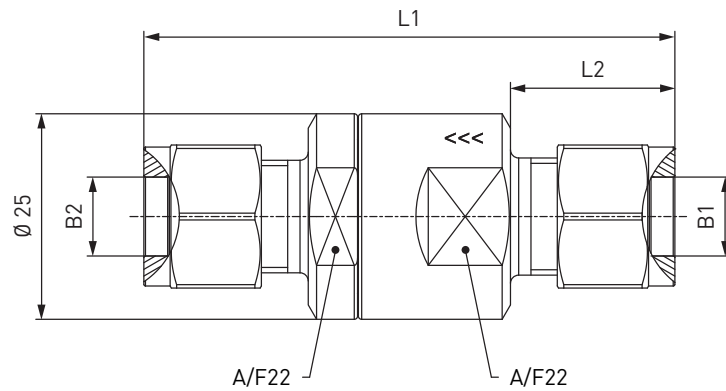

Part No.	Description	TNW	Pressure (MAWP)	B1	B2	L1	L2
On request	TVR1 H ₂ (EC79)	8 mm	45 MPa	Tube Ø 3/8**	Tube Ø 3/8**	65.0	20.0
On request	TVR1 H ₂ (EC79)	8 mm	45 MPa	Tube Ø 10*	Tube Ø 10*	65.0	20.0

* double ferrule fitting

Other connection sizes and types (e.g. Cone and Thread Fittings or VOSSLok⁴⁰) on request.

» Check valve TVR5 H₂

DESCRIPTION



Features

- Robust construction
- Low-noise opening and closing
- Corrosion resistant stainless steel
- High leak tightness

With the TVR5 H₂ WEH offers a high-performance check valve especially for hydrogen buses and trucks. The WEH[®] TVR5 H₂ check valves provide a reliable function wherever hydrogen should only flow in one direction within a pipe system and must be prevented from a return flow.

The seals in the valve are arranged to prevent them from being damaged by dirt particles in the gas flow. The WEH[®] TVR5 H₂ Check valve is made of corrosion-resistant stainless steel achieving a very durable unit due to its robust internal structure.

Application

Check valve for buses and trucks, also suitable for installation in hydrogen fueling stations.

The WEH[®] TVR5 H₂ product family is offered as a return flow prevention acc. to DIN EN 736-1 for installation in H₂ systems and pipelines.

TECHNICAL DATA

Characteristics	Basic version
Technical nominal size (TNW)	Depending on design
Nominal Pressure	PN = 35 MPa
Max. allowable operating Pressure	MAWP = 45 MPa (PS = 450 bar)
Temperature range	-40°C up to +85°C
Material	Corrosion resistant stainless steel
Sealing material	Hydrogen resistant
Design	Incl. fittings (only for check valves with tube fitting)
Conformity / Tests / Approvals	On request

Other designs on request

» Check valve TVR5 H₂

ORDERING | WEH® TVR5 H₂ Check valve with tube fitting on both sides

approx. dimensions (mm)

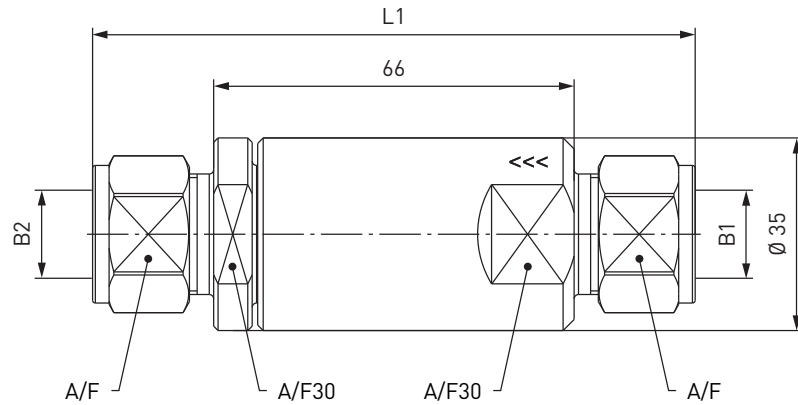

Part No.	Description	TNW	Pressure (PS)	B1	B2	L1	A/F
C1-30216-X1-X01	TVR5 H ₂	10.5 mm	45 MPa	Tube Ø 12*	Tube Ø 12*	110	22
C1-30215-X1-X01	TVR5 H ₂	14 mm	45 MPa	Tube Ø 16*	Tube Ø 16*	111	25

* double ferrule fitting

Other connection sizes and types (e.g. Cone and Thread Fittings or VOSSLok⁴⁰) on request.

» Filter TSF2 H₂

DESCRIPTION



Features

- For clean filtered hydrogen
- Filter insert can be cleaned
- For installation onboard H₂ vehicles and in H₂ fueling stations
- Also suitable as prefilter for inline breakaway couplings

When refueling hydrogen, it can often happen that hydrogen with dirt particles is fueled. These contaminated particles in the gas may cause damage to the sealing components. WEH therefore offers the WEH[®] TSF2 H₂ Filter for clean filtered hydrogen. Solid particles are reliably captured.

The filter element can be removed and can be reused after cleaning.

The WEH[®] TSF2 H₂ Filter is mainly used in fueling stations and plants.

To meet the different requirements of dispenser manufacturers, a wide variety of connection configurations are available - tube fitting / female thread on both ends or female and male thread.

For use as a prefilter with WEH[®] TSA2 H₂ Inline breakaway coupling, WEH offers a special design with male and female thread.

Application

Filter for installation in hydrogen vehicles and fueling stations.

TECHNICAL DATA

Characteristics	Basic version
Technical nominal size (TNW)	Depending on design
Nominal pressure	PN = 35 MPa
Max. allowable operating pressure	MAWP = 45 MPa (PS = 450 bar)
Temperature range	-40°C up to +85°C
Material	Corrosion resistant stainless steel
Sealing material	Hydrogen resistant
Filter element	40 µm or 20 µm
Design	Incl. fittings (only for filters with tube fitting)
Conformity / Tests / Approvals	On request

Other designs on request

» Filter TSF2 H₂

ORDERING | WEH® TSF2 H₂ Filter with tube fitting on both sides

approx. dimensions (mm)

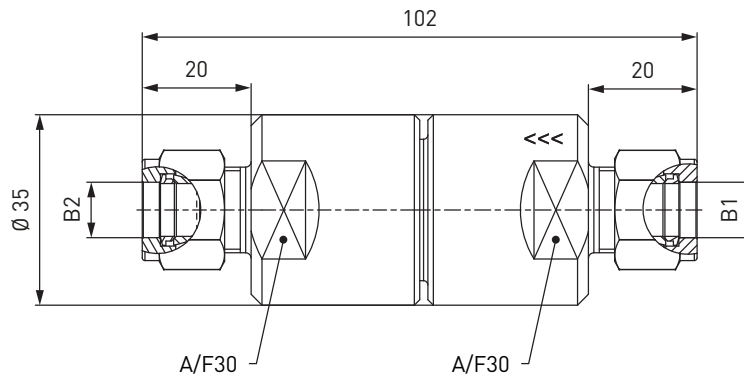

Part No.	Description	Filter (µm)	TNW	Pressure (MAWP)	B1	B2
C1-18487-X01	TSF2 H ₂	40	8 mm	45 MPa	Tube Ø 3/8"*	Tube Ø 3/8"*
C1-36033-X01	TSF2 H ₂	40	8 mm	45 MPa	Tube Ø 10*	Tube Ø 10*

* double ferrule fitting

ORDERING | WEH® TSF2 H₂ Filter with female thread on both sides

approx. dimensions (mm)

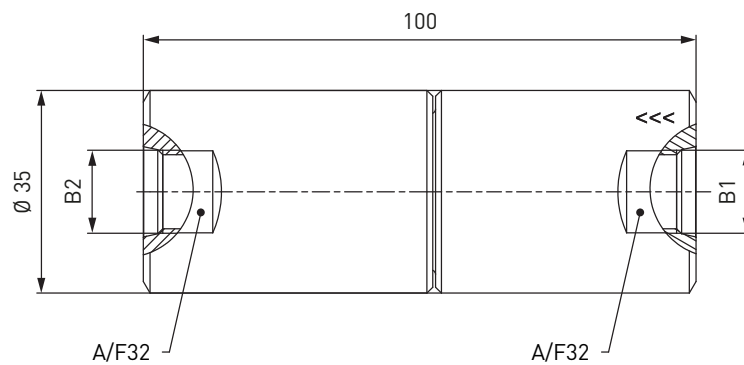

Part No.	Description	Filter (µm)	TNW	Pressure (MAWP)	B1 (female thread)	B2 (female thread)
C1-34576-X01	TSF2 H ₂	40	8 mm	45 MPa	UNF 9/16"-18*	UNF 9/16"-18*

* acc. to SAE J1926-1

» Filter TSF2 H₂

ORDERING | WEH® TSF2 H₂ Filter with male and female thread (also suitable as prefilter for TSA2 H₂)
approx. dimensions (mm)

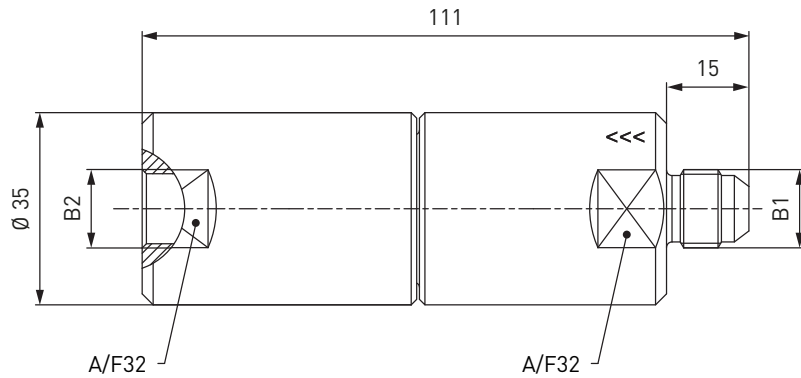

Part No.	Description	Filter (μm)	TNW	Pressure (MAWP)	B1 (male thread)	B2 (female thread)
C1-134710-X01	TSF2 H ₂	40	8 mm	45 MPa	UNF 9/16"-18*	UNF 9/16"-18*
C1-134711-X01	TSF2 H ₂	20	8 mm	45 MPa	UNF 9/16"-18*	UNF 9/16"-18*

* acc. to SAE J514, 37° cone

Other connection sizes and types (e.g. Cone and Thread Fittings or VOSSLok⁴⁰) on request.

» Filter TSF2 H₂

SPARE PARTS

Various parts are available as spares for the WEH[®] TSF2 H₂ Filter.

Part No.	Description
E69-9061	Wire filter insert 40 µm (incl. spring and o-ring)
W67754	Wire filter insert 20 µm (incl. spring and o-ring)

» Coalescing filter TSF2 H₂



DESCRIPTION



Features

- Fine filter with high particle retention capacity (efficiency of approx. 99.9 % > 0.3 μm)
- Operating pressure (PS) up to 490 bar
- For installation in H₂ vehicles and fueling stations
- Protection of critical components in the fuel system
- Wear resistant and corrosion resistant
- Ease of maintenance

When refueling with hydrogen, clean, filtered gases are a basic prerequisite for the proper functioning of the vehicle and fueling station components. The WEH[®] TSF2 H₂ coalescence filter cleans the gas flow of contaminants.

Coalescence filters are even more effective than normal particle filters due to their high particle retention capacity. more effective. The TSF2 H₂ filters the gas flow and reliably and safely removes the contaminants contained in the gas, such as oil, water aerosols and dirt particles. These impurities are separated by the coalescence filter. The hydrogen flows through the filter, whereby the slower-flowing components such as oil, water and other liquid aerosols form droplets, sink to the bottom of the filter and can be removed via the oil outlet.

The WEH[®] TSF2 H₂ is easy to maintain and can also be retrofitted in vehicles and fueling stations.

Application

Coalescence filters for installation in hydrogen vehicles and fueling stations.

TECHNICAL DATA

Characteristics	Basic version
Technical nominal size (TNW)	8 mm
Nominal pressure	PN = 35 MPa
Max. allowable operating pressure	PS (MAWP) according to design
Temperature range	-40°C up to +85°C
Material	Corrosion resistant
Sealing material	Hydrogen resistant
Filterelement	< 0,3 μm
Ausführung	Incl. Plug
Konformitäten / Prüfungen / Zulassungen	00 0004 (Ordinance (EG) Nr. 79/2009)

Other designs on request

» Coalescing filter TSF2 H₂

ORDERING | Coalescing filter WEH® TSF2 H₂ with filter cartridge Ø 38 mm

approx. dimensions (mm)

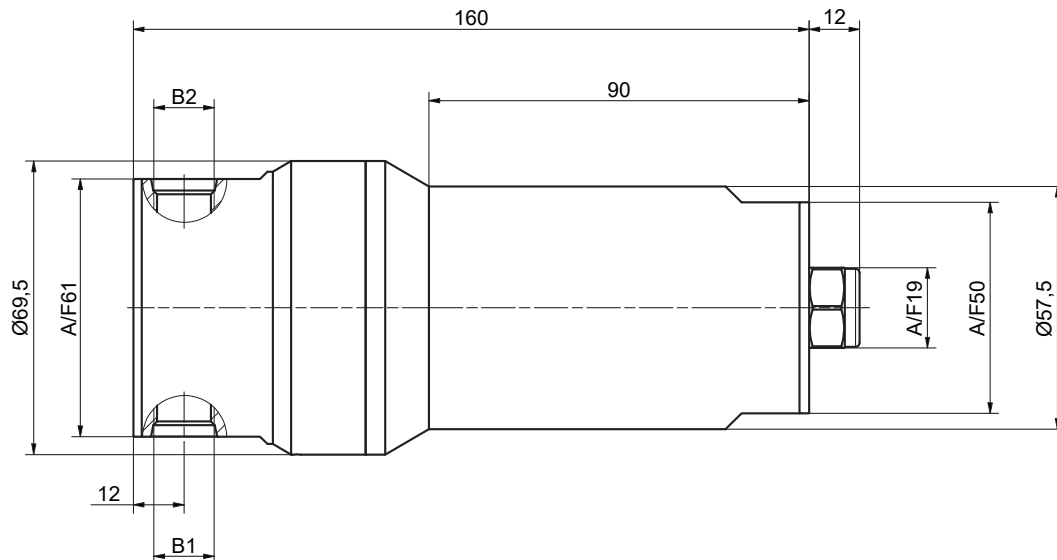

Part No.	Description	Pressure (MAWP)	B1 (female thread)	B2 (female thread)
C1-181946	TSF2 H ₂ (EG79)	43.75 MPa	UNF 9/16"-18*	UNF 9/16"-18*
C1-181949	TSF2 H ₂	49 MPa	UNF 9/16"-18*	UNF 9/16"-18*

* according to SAE J1926-1

Other connections (e.g. Cone and Thread Fittings or VOSSLok40) on request.

SPARE PARTS / ACCESSORIES

Various spare parts are available for the WEH® TSF2 H₂ coalescence filter.

Plug

Plug with matching O-ring (made of polyurethane) to close the oil outlet "Q" (filter end).



Part No.	Description	Connection (male thread)
E69-93336	Plug with O-Ring	UNF 9/16"-18*

* according to SAE J1926-1

Spare parts set

Suitable for coalescence filter TSF2 H₂.

Part No.	Description
B200B-168192	Spare parts set consisting of filter cartridge Ø 38 mm, support ring and 2 O-rings

Screw-in fittings for connections B1/B2

Part No.	Description
E69-135408	Swagelok UNF 9/16"-18* AG RV Ø10mm
E69-155000	Swagelok UNF 9/16"-18* AG RV Ø8mm

* according to SAE J1926-1
Tightening torque 45 Nm + 10%

» Filter TSF4 H₂

DESCRIPTION



Features

- For clean filtered hydrogen
- Filter insert can be cleaned
- For installation onboard H₂ vehicles and in H₂ fueling stations

When refueling hydrogen, it can often happen that hydrogen with dirt particles is fueled. These contaminated particles in the gas may cause damage to the sealing components. WEH therefore offers the WEH® TSF4 H₂ Filter for clean filtered hydrogen. Solid particles are reliably captured.

The filter element can be removed and can be reused after cleaning.

The particle filter is specially designed for installation in vehicles, but can also be installed in fueling stations and plants, depending on the application.

Application

Filter for installation in hydrogen vehicles and fueling stations.

TECHNICAL DATA

Characteristics	Basic version
Technical nominal size (TNW)	10 mm
Nominal pressure	PN = 35 MPa
Max. allowable operating pressure	According to design
Temperature range	-40°C up to +85°C
Material	Corrosion resistant stainless steel
Sealing material	Hydrogen resistant
Filter element	10 µm
Design	Incl. fittings (only for filters with tube fitting)
Conformity / Tests / Approvals	On request

Other designs on request

» Filter TSF4 H₂

ORDERING | WEH® TSF4 H₂ T-Filter with tube fitting on both sides

approx. dimensions (mm)

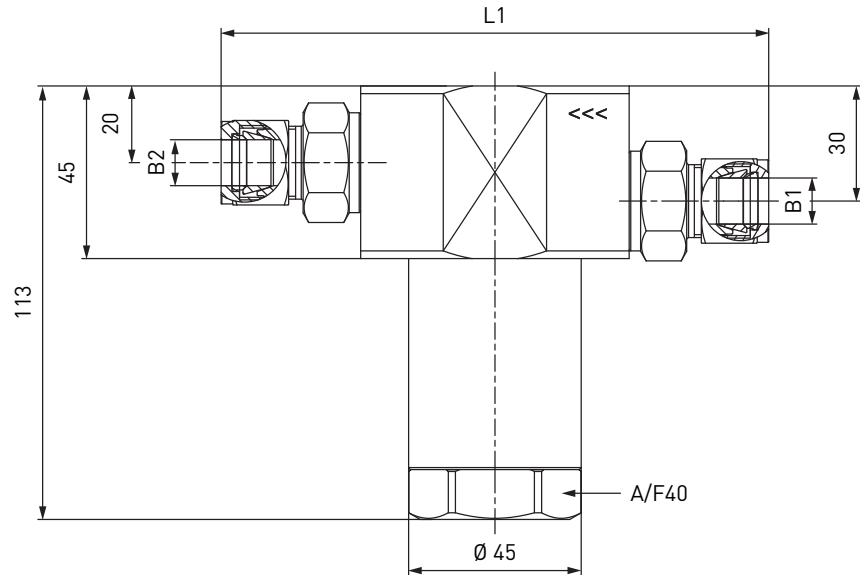

Part No.	Description	Filter (µm)	TNW	Pressure (MAWP)	B1	B2	L1
C1-58026-X01	TSF4 H ₂	10	10 mm	45 MPa	Tube Ø 12*	Tube Ø 12*	145
C1-73987-X01	TSF4 H ₂	10	10 mm	35 MPa	Tube Ø 1/2"	Tube Ø 1/2"	145

* double ferrule fitting

Other connection sizes and types (e.g. Cone and Thread Fittings or VOSSLok⁴⁰) on request.

SPARE PARTS

Various parts are available as spares for the WEH® TSF4 H₂ Filter.

Part No.	Description
W9063	Wire filter insert 10 µm
E51-47589	O-ring for filter insert (only T-filter)

» Defueling nozzle TK6 H₂

DESCRIPTION

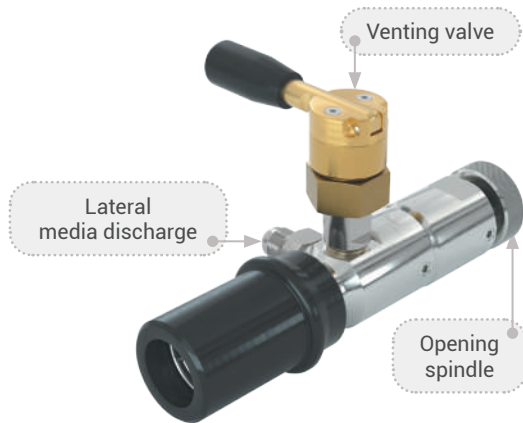

Features

- Discharge via filling port
- Actuation with opening spindle
- With venting valve (optionally also without venting valve)
- No additional shut-off device required
- Plastic thermal protection on vehicle-side connection
- Only suitable for WEH[®] TN1 H₂ Receptacles without filter

The WEH[®] TK6 H₂ Defueling nozzle is used for maintenance and inspection of hydrogen vehicles. For maintenance, all pressure or fuel tanks must be discharged. WEH has designed the TK6 H₂ for easy connection and discharging of the hydrogen tanks.

The defueling nozzle is simply placed onto the receptacle in the car and the knurled spindle is screwed in until it stops. Then, the WEH[®] TN1 H₂ Receptacle is opened and the fuel tanks can be discharged via the lateral media discharge.

Application

Defueling nozzle for discharging hydrogen fuel tanks of cars via filling receptacle, only to be used with WEH[®] TN1 H₂ Receptacles without filter. Operation only by specially trained personnel. Not for self-service operation!

Attention: The TK6 H₂ may not be used for filling!

TECHNICAL DATA

Characteristics	Basic version
Technical nominal size (TNW)	6 mm
Nominal pressure	PN = 35 MPa
Max. allowable operating pressure	PS = 45 MPa
Media temperature range	-20°C up to +85°C
Ambient temperature range	-40°C up to +85°C
Material	Corrosion resistant
Sealing material	Hydrogen resistant
Design	With plastic thermal protection on vehicle-side connection, opening spindle and venting valve
Weight	Approx. 1.2 kg

Other designs on request

» Defueling nozzle TK6 H₂

ORDERING | WEH® TK6 H₂ Defueling nozzle with venting valve

approx. dimensions (mm)

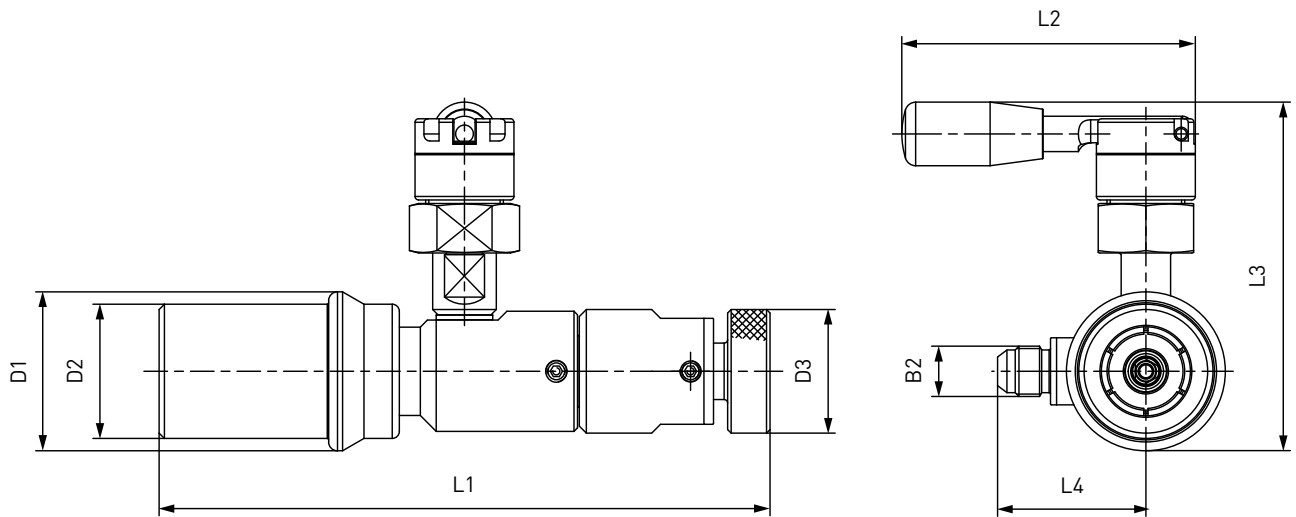

Part No.	Description	Pressure (MAWP)	B2 (male thread)	L1	L2	L3	L4	D1	D2	D3
C1-104732-X01	TK6 H ₂	45 MPa	UNF 9/16"-18*	min. 173 / max. 180	83	99	42	45	38	35

* acc. to SAE J514, 37° cone

» Defueling nozzle TK6 H₂

ACCESSORIES

The following accessories are available for the WEH® TK6 H₂ Defueling nozzle:

Pressure hose

Pressure hose for connection to the defueling nozzle, complete with fittings and press-fittings supported by coil spring stubs.
 Not suitable for refueling with pre-cooled hydrogen acc. to SAE J2601.
 Design hose: max. operating pressure PS: 45 MPa / nominal bore for fitting: 4.5 mm / media temperature range: -20°C up to +90°C



Part No.	B1/B2 (female thread)	Hose length
E68-60809	UNF 9/16"-18*	3 m
E68-60812	UNF 9/16"-18*	4 m
E68-60813	UNF 9/16"-18*	5 m

* acc. to SAE JIC, 37° cone

WEH® TN1 H₂ Receptacle with tube fitting, without filter

approx. dimensions (mm)

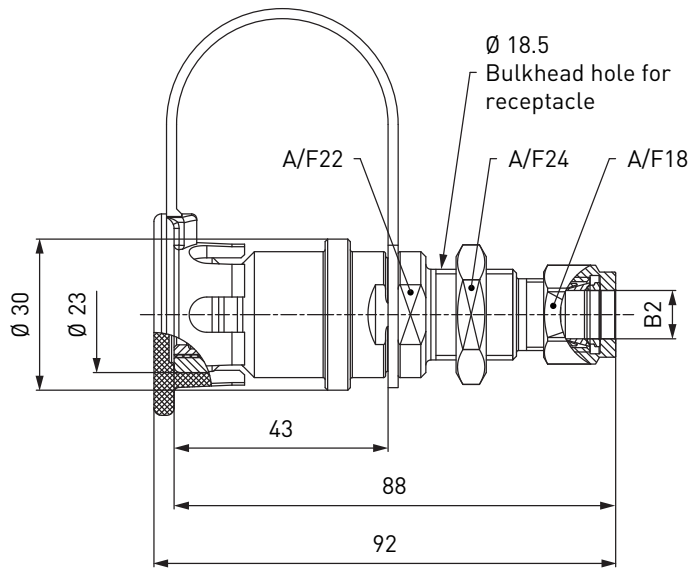

Part No.	Description	TNW	Pressure (MAWP)	B2
C1-18481/4-X01	TN1 H ₂	8 mm	43,75 MPa	Tube Ø 3/8**
C1-32456-X01	TN1 H ₂ (EC79)	8 mm	43,75 MPa	Tube Ø 10*

* double ferrule fitting

» Defueling nozzle TK6 H₂

WEH® TNS1 H₂ Service receptacle

To prevent damage in the defueling nozzle while leak testing during maintenance in the course of which pressure is applied, we recommend the use of a service receptacle. The receptacle also protects the defueling nozzle from dirt ingress whilst not in use.



Part no.	Description
C1-157639	TNS1 H ₂ Service receptacle incl. protection cap

SPARE PARTS

Various parts are available as spares for the WEH® TK6 H₂ Defueling nozzle.



Part no.	Description
E80-111760	1 Sliding sleeve
On request	Maintenance spray

» H₂ Hoses

DESCRIPTION

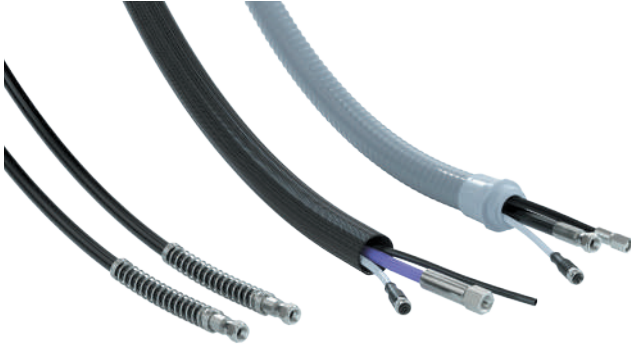

Features

- Different lengths available
- Tailor-made according to customers' specifications

We offer hydrogen hoses for connecting our fueling nozzles to the breakaway coupling or fueling station. The hoses are available with suitable fittings. The hoses or hose sets can be delivered in different standard sizes. On request the hydrogen hoses are also available in other lengths.

Application

Hydrogen hoses / hose sets for installation at the fueling station.

TECHNICAL DATA

Characteristics	Basic version
Max. allowable operating pressure PS	45 MPa (hoses for TK16 H ₂ , TK16 H ₂ High-Flow, TK25 H ₂ , TK6 H ₂) 49 MPa (hoses for TK20-S2 H ₂ 35 MPa) 87.5 MPa (hoses for TK20-S1 H ₂ 70 MPa)
Media temperature range	-20°C up to +90°C* (hoses for TK16 H ₂ , TK16 H ₂ High-Flow, TK25 H ₂ , TK6 H ₂) -40°C up to +85°C (hoses for TK20-S1 H ₂ 70 MPa, TK20-S1 H ₂ 35 MPa)
Ambient temperature range	-40°C up to +85°C
Sealing material	Hydrogen resistant

* not suitable for refueling with pre-cooled hydrogen acc. to SAE J2601

ORDERING | Hose set for TK20-S1 H₂ 70 MPa

Hose set for connecting fueling nozzle and TSA30-S1 H₂ 70 MPa breakaway coupling, complete with filling hose and braided protection hose as cover.

Design filling hose:

max. operating pressure PS: 96.25 MPa / nominal size at fitting: 4.5 mm / media temperature range: -40°C up to +85°C



Part no.	B1/B2 (female thread)	P1/P2	Hose length
C1-189992	UNF 9/16"-18*	Ø 6/4 mm	3 m
C1-189993	UNF 9/16"-18*	Ø 6/4 mm	4 m
C1-189994	UNF 9/16"-18*	Ø 6/4 mm	5 m

* DKJ 58°

» H₂ Hoses

ORDERING | Hose set for TK20-S1 H₂ 70 MPa ENR

Hose set for connecting fueling nozzle and TSA30-S1 H₂ 70 MPa breakaway coupling, complete with filling hose, data cable, purging line and braided protection hose as cover.

Design filling hose:

max. operating pressure PS: 96.25 MPa / nominal size at fitting: 4.5 mm / media temperature range: -40°C up to +85°C

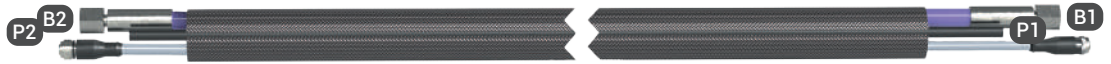

Part no.	B1/B2 (female thread)	P1/P2	Hose length
E68-161886	UNF 9/16"-18*	Ø 6/4 mm	3 m
E68-161887	UNF 9/16"-18*	Ø 6/4 mm	4 m
E68-161888	UNF 9/16"-18*	Ø 6/4 mm	5 m

* DKJ 58°

ORDERING | Hose set for TK20-S2 H₂ 35 MPa

Hose set for connecting fueling nozzle and TSA30-S1 H₂ breakaway coupling, complete with filling hose, purging line and braided protection hose as cover.

Design filling hose:

max. operating pressure PS: 49 MPa / nominal size at fitting: 4.5 mm / media temperature range: -40°C up to +85°C



Part no.	B1/B2 (female thread)	P1/P2	Hose length
C1-189989	UNF 7/16"-20*	Ø 6/4 mm	3 m
C1-189990	UNF 7/16"-20*	Ø 6/4 mm	4 m
C1-189991	UNF 7/16"-20*	Ø 6/4 mm	5 m

* according to SAE JIC, 37° sealing cone

ORDERING | Hose set for TK20-S2 H₂ 35 MPa ENR

Hose set for connecting fueling nozzle and TSA1 H₂ breakaway coupling, complete with filling hose, data cable, purging line and braided protection hose as cover.

Design filling hose:

max. operating pressure PS: 49 MPa / nominal size at fitting: 4.5 mm / media temperature range: -40°C up to +85°C



Part no.	B1/B2 (female thread)	P1/P2	Hose length
E68-174299	UNF 7/16"-20*	Ø 6/4 mm	3 m
E68-174300	UNF 7/16"-20*	Ø 6/4 mm	4 m
E68-174301	UNF 7/16"-20*	Ø 6/4 mm	5 m

* acc. to SAE JIC, 37° sealing cone

» H₂ Hoses

ORDERING | Hose set for TK20-S3 H₂ 35 MPa Medium-Flow

Hose set for connecting fueling nozzle and TSA30-S1 H₂ breakaway coupling, complete with filling hose, purging line and braided protection hose as cover.

Design filling hose:

max. operating pressure PS: 49 MPa / nominal size at fitting: 4.5 mm / media temperature range: -40°C up to +85°C



Part no.	B1/B2 (female thread)	P1/P2	Hose length
C1-189989	UNF 7/16"-20*	Ø 6/4 mm	3 m
C1-189990	UNF 7/16"-20*	Ø 6/4 mm	4 m
C1-189991	UNF 7/16"-20*	Ø 6/4 mm	5 m

* according to SAE JIC, 37° sealing cone

ORDERING | Hose set for TK20-S3 H₂ 35 MPa ENR Medium-Flow

Hose set for connecting fueling nozzle and TSA1 H₂ breakaway coupling, complete with filling hose, data cable, purging line and braided protection hose as cover.

Design filling hose:

max. operating pressure PS: 49 MPa / nominal size at fitting: 4.5 mm / media temperature range: -40°C up to +85°C



Part no.	B1/B2 (female thread)	P1/P2	Hose length
E68-174299	UNF 7/16"-20*	Ø 6/4 mm	3 m
E68-174300	UNF 7/16"-20*	Ø 6/4 mm	4 m
E68-174301	UNF 7/16"-20*	Ø 6/4 mm	5 m

* acc. to SAE JIC, 37° sealing cone

ORDERING | Hose set for TK16 H₂ 35 MPa and TK16 H₂ High-Flow 35 MPa

Hose set for connecting fueling nozzle and TSA1 H₂ breakaway coupling, complete with filling and venting hose, fittings and press-fittings supported by coil spring stubs. Not suitable for refueling with pre-cooled hydrogen acc. to SAE J2601.

Design filling/venting hose:

max. operating pressure PS: 45 MPa / nominal size at fitting: 4.5 mm / media temperature range: -20°C up to +90°C



Part No.	B1/B2 (female thread)	C1/C2 (female thread)	Hose length
C1-60917	UNF 9/16"-18*	UNF 7/16"-20*	3 m
C1-60920	UNF 9/16"-18*	UNF 7/16"-20*	4 m
C1-60923	UNF 9/16"-18*	UNF 7/16"-20*	5 m

* acc. to SAE JIC, 37° cone

» H₂ Hoses

ORDERING | Hose set for TK16 H₂ (35 MPa) and TK16 H₂ High-Flow (35 MPa) with data interface

Hose set for connecting fueling nozzle and TSA1 H₂ breakaway coupling, complete with filling and venting hose, hose fittings, plastic spiral hose and cable for data interface.

Not suitable for refueling with pre-cooled hydrogen acc. to SAE J2601.

Design filling/venting hose: max. operating pressure PS: 45 MPa / nominal size at fitting: 4.5 mm (filling hose)
resp. 2 mm (venting hose) / media temperature range: -20°C up to +90°C

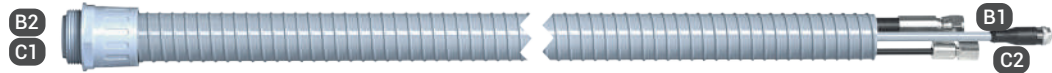

Part No.	B1/B2 (female thread)	C1/C2 (female thread)	Hose length
C1-90698	UNF 9/16"-18*	M12x1.5	3 m
C1-94428	UNF 9/16"-18*	M12x1.5	4 m
C1-94429	UNF 9/16"-18*	M12x1.5	5 m

* acc. to SAE JIC, 37° cone

ORDERING | Hose set for TK25 H₂ (25 MPa / 35 MPa)

Hose set for connecting fueling nozzle and TSA5 H₂ breakaway coupling, complete with filling and venting hose, fittings and press-fittings supported by coil spring stubs. Not suitable for refueling with pre-cooled hydrogen acc. to SAE J2601.

Design filling/venting hose: max. operating pressure PS: 45 MPa / nominal size at fitting: 5.6 mm (filling hose)
resp. 4.5 mm (venting hose) / media temperature range: -20°C up to +90°C



Part No.	B1/B2 (female thread)	C1/C2 (female thread)	Hose length
C1-152556	UNF 7/8"-14*	UNF 9/16"-18*	3 m
C1-152557	UNF 7/8"-14*	UNF 9/16"-18*	4 m
C1-152558	UNF 7/8"-14*	UNF 9/16"-18*	5 m

* acc. to SAE JIC, 37° cone

ORDERING | Pressure hose for TK6 H₂ (35 MPa)

Pressure hose for connecting to the defueling nozzle, complete with fittings and press-fittings supported by coil spring stubs. Not suitable for refueling with pre-cooled hydrogen acc. to SAE J2601.

Design hose:

max. operating pressure PS: 45 MPa / nominal size at fitting: 4.5 mm / media temperature range: -20°C up to +90°C



Part No.	B1/B2 (female thread)	Hose length
E68-60809	UNF 9/16"-18*	3 m
E68-60812	UNF 9/16"-18*	4 m
E68-60813	UNF 9/16"-18*	5 m

* acc. to SAE JIC, 37° cone

Service receptacle TNS12-S1 H₂



DESCRIPTION



Features

- Integriertes Absperrventil
- Geräuscharme Entleerung
- Dichtungsschonende Bauart
- Inkl. Schutzkappe

Hydrogen vehicles must be regularly maintained and checked. This requires the hydrogen system in question to be drained. The WEH® TNS12-S1 H₂ service receptacle was specially developed for this purpose. It is mounted on the body panel of the hydrogen vehicle, for example, and enables the hydrogen system to be emptied easily. The TNS12-S1 H₂ is self-locking.

The matching WEH® TW110 H₂ service connector is also available for the WEH® TNS12-S1 H₂ service receptacle. This is simply connected to the service receptacle and draining can begin. Once draining is complete, the service connector is closed again.

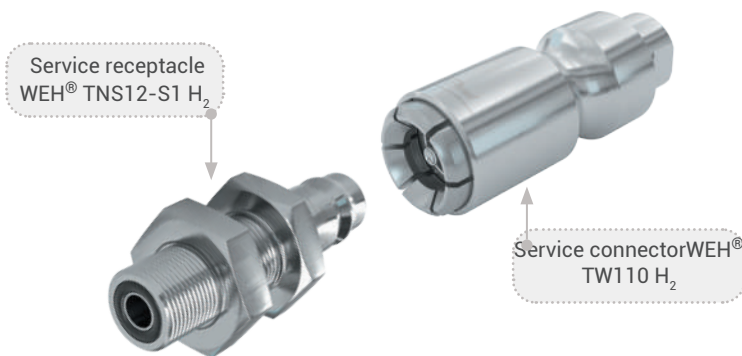

Application

Service receptacle for draining hydrogen systems.
Operation by trained personnel only, not for self-service use!
Attention: The TNS12-S1 H₂ must not be used for filling!

TECHNICAL DATA

Characteristics	Basic version
Technical nominal size (TNW)	3 mm
Nominal pressure	PN= 2.11 MPa
Max. allowable operating pressure	MAWP = 2.9 MPa
Temperature range	-40°C up to +105°C
Material	Corrosion resistant
Sealing material	Hydrogen resistant

Other designs on request

» Service receptacle TNS12-S1 H₂

ORDERING | Service receptacle WEH® TNS12-S1 H₂
approx. dimensions (mm)

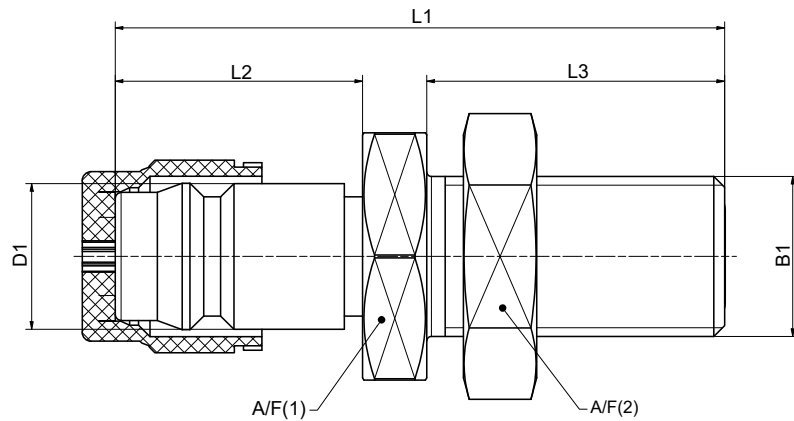

Part No.	Description	TNW	Pressure (MAWP)	B1 (male thread)	L1	L2	L3	D1	A/F(1) / A/F(2)
On request	TNS12-S1 H ₂	3 mm	2.9 MPa	UN 11/16"-16 for sealing with O-Lok® Face Seal* for tube Ø 10 (3/8")	66.5	27	32.5	16	27

* Face Seal nach SAE J1453-1

» Service receptacle TNS12-S1 H₂

ACCESSORIES

The following accessories are available for the WEH® TNS12-S1 H₂ service receptacle:

Service connector WEH® TW110 H₂

Service connector with integrated shut-off valve for draining the pressure and fuel tanks of hydrogen-powered vehicles.

approx. dimensions (mm)

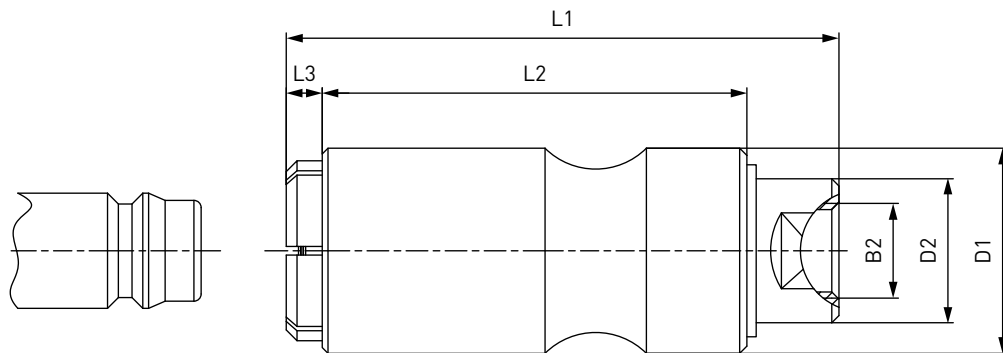

Part No.	Description	DN	Pressure (MAWP)	B2 (female thread)	L1	L2	L3	D1	D2
C1-84461	TW110 H ₂	8	2 MPa	G1/4"	77	59	5	28.5	20

» Service receptacle TNS12-S1 H₂

SPARE PARTS

Various spare parts are available for the WEH® TNS12-S1 H₂ service receptacle.

Protection cap

To protect the TNS12-S1 H₂ service receptacle from dirt and damage when not in use.



Part No.	Description
C1-185225	protection cap with loss protection

» Quick Connector TW850-S60 H₂



DESCRIPTION

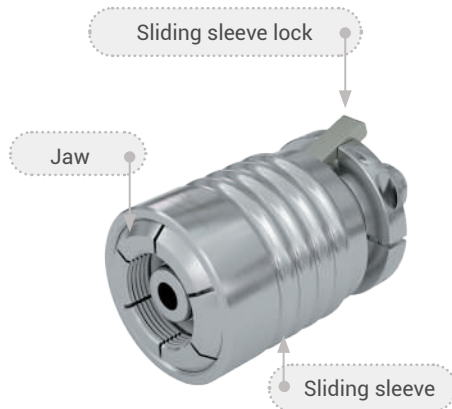

Features

- **Quick connector:** Laborious screwing on is not necessary - Connection and release in less than one second
- **High flow values:** Continuous technical nominal width of 10 mm for **maximum flow rate**
- **Compatibility:** Suitable for typical tube connections on H₂ trailers
- **Grip sleeve lock:** Prevents unintentional loosening of connector
- **H₂ compatibility:** Optimized for hydrogen applications with **high operating pressures**
- **Robust design:** Durable and reliable even under the most demanding conditions

The challenge is reliable supply of hydrogen fueling stations if hydrogen cannot be produced directly on site. Along with the establishment of an H₂ pipeline network, trailers for fine distribution are required that can transport hydrogen from central filling stations to fueling stations. The connection of the lines to these trailers is currently accomplished using mostly tube fittings, which are time-intensive and require special training.

The WEH[®] Connector TW850-S60 H₂ 530 bar is the optimal solution for safe, fast and efficient filling of hydrogen tanks, such as H₂ trailers for fueling station supply, with a maximum operating pressure of up to 530 bar.

Thanks to the innovative clamping jaw mechanism and continuous technical nominal width of 10 mm, the quick connector enables the highest flow values and significantly reduces filling time. Easy handling and the elimination of laborious tube fittings make the TW850-S60 H₂ 530 bar an essential tool for filling hydrogen trailers and suppliers.

Thanks to the integrated locking lever, unintentional loosening of the connector is reliably prevented, which maximizes safety during the filling process. With its H₂ compatibility and robust design, the TW850-S60 H₂ 530 bar sets new standards in hydrogen logistics and supports the growing demand for efficient solutions for the energy revolution.

Areas of use and applications

Filling hydrogen containers, e.g. H₂ trailers for fueling station supply, with a max. operating pressure of up to 530 bar.

Note: The connector is not designed for fueling H₂ vehicles.

The media flow must be blocked off using a separate valve, there is no check valve in the TW850-S60 H₂ 530 bar.

» Quick Connector TW850-S60 H₂

TECHNICAL DATA

Characteristics	Basic version
Technical nominal size (TNW)	up to 10 mm, depending on design
Max. allowable operating pressure	PS = up to 530 bar, depending on design
Temperature range	-40°C to +65°C
Medium	Hydrogen
Leak rate	1 x 10 ⁻³ mbar x l/s, measured with 100% helium
Materials	Corrosion resistant
Sealing material	NBR
Actuation	Manual via the sliding sleeve

» Quick Connector TW850-S60 H₂

ORDERING | WEH® TW850-S60 450 bar quick connector

approx. dimensions (mm)

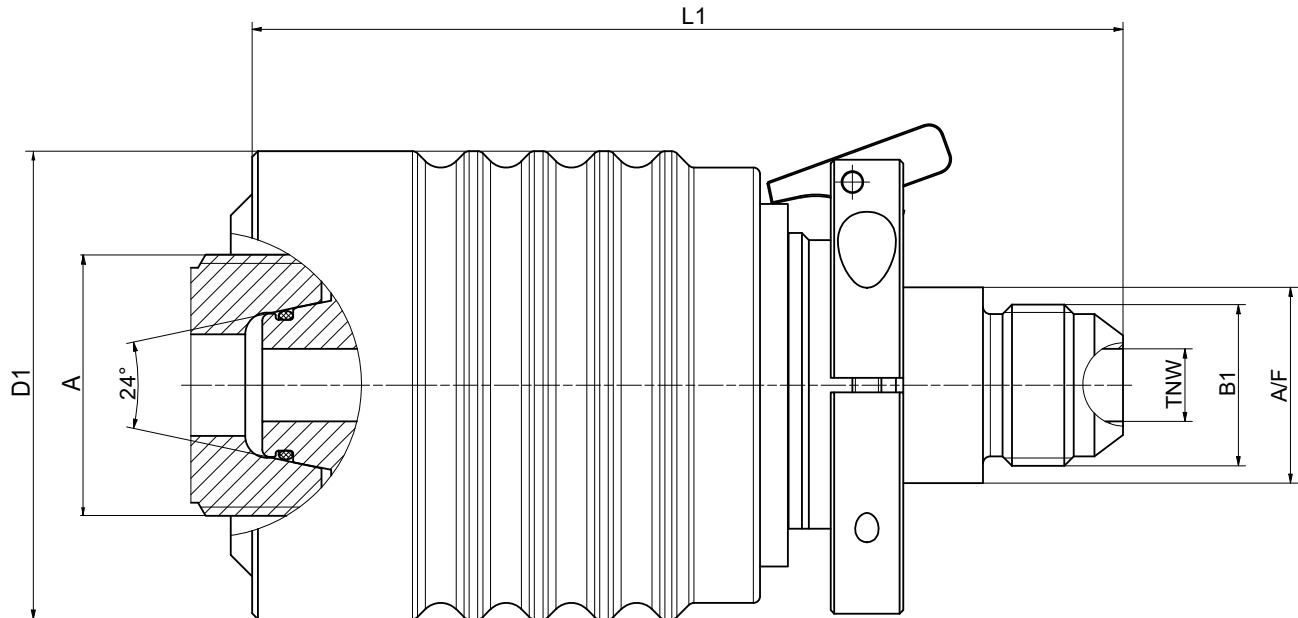

Part no.	Body size	Max. operating pressure (PS)	Technical nominal size (TNW)	Connection size A (male thread)	Connection standard A	B1 (male thread)	L1	D1	A/F
C1-190856	2	450 bar	5 mm	W21.8x1/14" - LH	DIN 477-1	7/8"-14 UNF*	109	47	24
C1-189758	4	450 bar	7 mm	W30x2.0 - LH	DIN EN ISO 5145 (No. 38)	7/8"-14 UNF*	119	57.5	27
C1-186400	6	450 bar	10 mm	M36x2.0-LH	DIN EN ISO 8434-1	7/8"-14 UNF*	120	64.5	27
C1-189766	7	450 bar	10 mm	M42x2.0 - LH	DIN EN ISO 8434-1	7/8"-14 UNF*	129	83	32
C1-190859	8	450 bar	10 mm	M52x2.0 - LH	DIN EN ISO 8434-1	7/8"-14 UNF*	130	93	32

*according to SAE J514, 37° outer cone

Other connection types on request.

» Quick Connector TW850-S60 H₂

ORDERING | WEH® TW850-S60 quick connector 530 bar

approx. dimensions (mm)

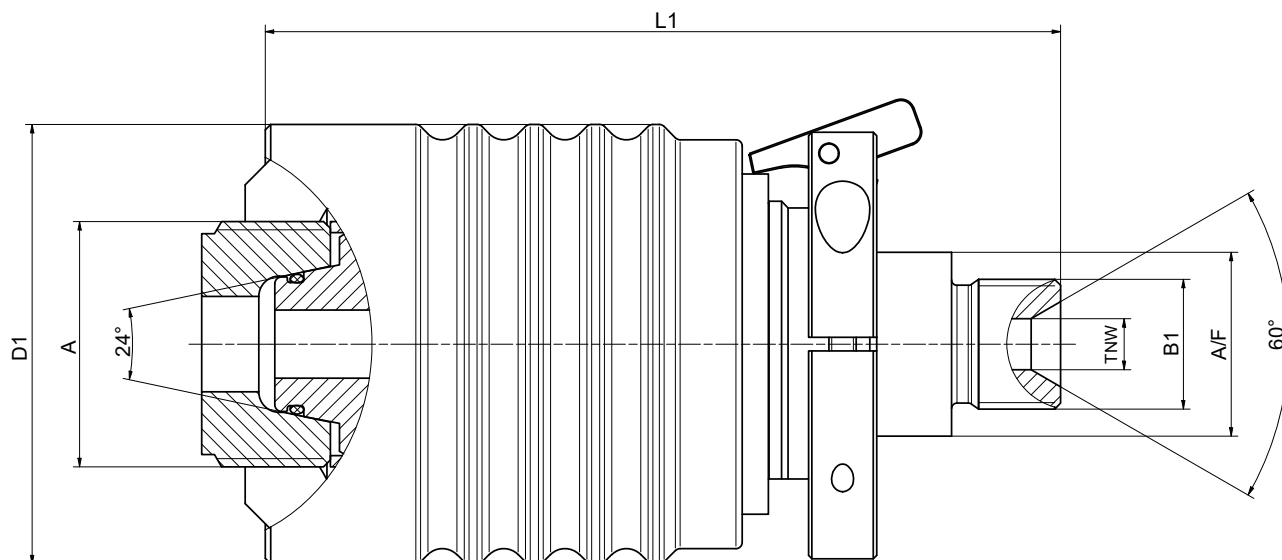

Part no.	Body size	Max. operating pressure (PS)	Technical nominal size (TNW)	Connection size A (male thread)	Connection standard A	B1 (male thread)	L1	D1	A/F
C1-190959	2	530 bar	7 mm	W21.8x1/14" - LH	DIN 477-1	3/4"-16 UNF	106	47.5	24
C1-189759	4	530 bar	5 mm	W30x2.0 - LH	DIN EN ISO 5145 (No. 38)	3/4"-16 UNF	116.	57.5	27
C1-189768	6	530 bar	7.5 mm	M36x2.0 - LH	DIN EN ISO 8434-1	3/4"-16 UNF	117	64.5	27
C1-189767	7	530 bar	7.5 mm	M42x2.0 - LH	DIN EN ISO 8434-1	3/4"-16 UNF	126	83	32
C1-190960	8	530 bar	7.5 mm	M52x2.0 - LH	DIN EN ISO 8434-1	3/4"-16 UNF	127	93	32

Other connection types on request.

ACCESSORIES

The following accessories are available for the WEH® TW850-S60 H₂ quick connector:

Pressure hose

Pressure hose for connection to the quick connector, complete with fittings.
Media temperature range: -40°C to +65°C

Part no.	Description	Technical nominal size (TNW)	Connection (female thread)	max. allowable operating pressure (PS)	Hose length
C1-143166	Pressure hose H ₂ 35 MPa	5.6 mm	UNF 7/8"-14	450 bar	4 m
C1-187988	Pressure hose H ₂ 70 MPa	7.5 mm	UNF 3/4"-16	962.5 bar	4 m

Other hose lengths are available on request.

» Manifold TMF900-S1 H₂



DESCRIPTION



Features

- **Reduces sealing points** in gas systems and vehicles
- **Simple and quick installation**
- Dimensions, type, and number of connections can be customized to customer requirements

Gas distributors reduce the number of sealing points and simplify installation, which can be carried out in a single block. They can be used to distribute gases to different pipes and to combine fittings in a manifold. Dimensions and the type and number of connections can be customized according to customer requirements. Filters, check valves, and other components can also be installed at the factory.

Application

Distribution block for hydrogen applications in gas engineering systems or vehicles.

TECHNICAL DATA

Characteristics	Basic version
Working Pressure WP	Depending on design
Temperature range	-40°C up to +85°C
Material	Stainless steel
Design	Distribution block with one media inlet and six outlets, as well as mounting holes.

Versions for other pressure ratings, media, and other connection combinations available on request.

» Manifold TMF900-S1 H₂

IMPLEMENTATION EXAMPLE | Manifold TMF900-S1 H₂

approx. dimensions (mm)

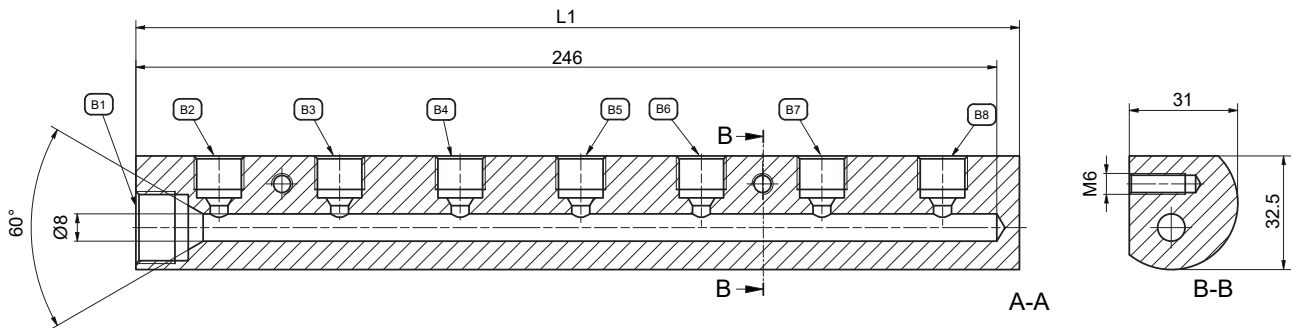

Part no.	Description	Pressure PS	B1 (female thread)	B2-B8 (female thread)	L1
C1-192622	TMF900-S1 H ₂	48.125 MPa	13/16"-16 UN	9/16"-18 UNF	253

» Technical appendix

Definitions

Abbreviation	Definition	
Pressure specifications	<i>(all pressure data is to be understood as overprint, unless otherwise stated)</i>	
PN	Nominal pressure	Nominal pressure after temperature compensation at 15°C (59 °F)
PS	Max. allowable operating pressure	Maximum allowable operating pressure acc. to Pressure Equipment Directive 2014/68/EU, Article 2 paragraph 8
PT	Hydrostatic test pressure	Hydrostatic test pressure acc. to Pressure Equipment Directive 2014/68/EU, Annex I no. 7.4
PP	Pilot pressure	Actuation pressure for hydraulic and pneumatic components
PC	Cracking pressure	Pressure at which the check valve opens and the first indication of flow occurs
WP	Working pressure	'Working pressure' means the maximum pressure to which a component is designed to be subjected to and which is the basis for determining the strength of the component under consideration
MAWP	Max. allowable working pressure	Max. allowable operating pressure at which the weakest point of the system or the vessel (e.g. cylinder valve) can operate at a certain temperature during normal operation
Dimensions		
L1, L2, L3 ...	Length specification	
D1, D2, D3 ...	Diameter specification	
A/F(1), A/F(2) ...	Wrench size specification	
Ports		
A / X	Customer-specific port (test piece, sample, cylinder valve, handwheel respiratory protective equipment)	
B1, B2, B3 ...	Media ports	
C1, C2, C3 ...	Gas recirculation ports	
P1, P2, P3 ...	Pilot pressure ports	
MA1, MA2 ...	Measuring ports	
Q	Drain port filter	
G	Mounting bores	
Others		
DN	Nominal size (DN) acc. to Pressure Equipment Directive 2014/68/EU, whereby the largest, pressurized diameter of the media or pilot pressure connections of the WEH Device (A, B1, B2, B3 or C1, C2, C3 and P1, P2, P3) which faces the customer's pipe system, is relevant. Expressed by a rounded, dimensionless number, e. g. DN 25.	
TNW	The technical nominal size (formerly expressed by "effective diameter") is the smallest diameter available for the media flow of the respective pressure device. Expressed by a number with unit, e. g. 12 mm.	
µm	Max. diameter of the filtered particle	
Kv	Is the discharge of water in m ³ /h at a pressure drop of 1 bar (14.5 psi), acc. to DIN/EN 60534-2	
Cv	Is the discharge of water in gallons per minute at a pressure drop of 1 psi, acc. to DIN/EN 60534-2	
IR	Infrared data interface	
ENR	Exchangeable data interface (exchangeable nozzle receiver)	
TS	Maximum allowable temperature acc. to Pressure Equipment Directive 2014/68/EU, Article 2 paragraph 9	

» Technical appendix

Definitions

Abbreviation	Definition
Breakaway force	Is the force range, in which the breakaway releases
NC	Normally closed (initial position of shut-off valve)
NO	Normally open (initial position of shut-off valve)

Technical explanations

Term	Definition
Temperature range	Is the temperature range in which the WEH® Product can be used. If no explicit information on medium and ambient temperature is given, this temperature range applies to both medium and environment.
Media temperature range	Is the temperature range of the medium used, which can flow through the WEH® Product (may change depending on the time of measurement).
Ambient temperature range	Is the temperature range of the environment in which the WEH® Product can be used.
Leak rate	Is the maximum external leak rate, which the WEH® Product exhibits in delivery condition.
Internal leak rate	The internal leak rate depends, among other things, on type of application, medium and pressure difference on the WEH® Product. On request it can be specified more precisely.
Max. side load	Is the max. allowable sum of all external forces that may act on the device under intended use. Note: External forces can affect the life time of WEH® Products and can cause damage. Tensile and transverse loads as well as vibrations and pressure impacts need to be considered, e.g. by user side measures such as on site mountings and similar. Therefore, lateral forces such as whipping hoses or other equipment must be avoided. WEH® Products should be installed in such a way, that lateral forces which could lead to leakage or damage can not occur. Special applications require a special consultation before selecting the product.
Products with pneumatic actuation	The customer has to ensure there is adequate axial movement when pneumatically actuated WEH® Products are used in automated systems, see maximum side load. Ideally the products should be mounted with a floating joint or introduced individually to prevent the possibly existing clamping jaws getting blocked or jammed in the thread of the test piece.
Sealing material	On request the WEH® Product can be adapted to customer specific applications regarding to the sealing materials used. The clarification of the media compatibility and suitability of the adapted WEH® Product for the final application is always the responsibility of the end user.
Corrosion resistant	WEH® Products are designed for use in temperate climate zones - with low levels of humidity and salinity in the air. An accelerated formation of rust or corrosion may occur at or near the sea. Therefore, reduce the inspection interval recommended for normal use and send in the WEH® Product for maintenance immediately if you notice increased soot, rust or corrosion.
Storage / life time of components	There are certain requirements for every WEH® Product. WEH® Products are generally products which may be subject to wear and fatigue during operation and depending on your individual application/use. For details - in particular regarding the corresponding minimum inspection and maintenance intervals – please refer to the respective operating instructions for the WEH® Product.

» Technical appendix

Further explanations

Subject	Definition
Technical data	Unless otherwise stated, the technical data in catalogs, data sheets and operating instructions are based on tests with nitrogen that are in the development phase or at the end of development. Leakage data are based on measurements with helium.
Intended use	For the intended use of WEH® Products, please refer to the respective operating instructions. The following applications are generally excluded for WEH® H ₂ and CNG products, unless these are expressly permitted in the operating instructions: <ul style="list-style-type: none"> • aerospace applications, e.g. in aircrafts • shipping applications • applications offshore and in littoral areas • applications within defense and weapons technology
Safe product selection	Our WEH® Products are designed to be operated by qualified professional users (insofar as WEH® Products are also designed to be operated by other users in individual cases, this is explicitly stated in the corresponding operating instructions). Please note that WEH does not know your system and therefore - also due to the large number of different potential applications of WEH® Products - cannot perform tests on all potential types of application. You alone are responsible for the selection, configuration and suitability of WEH® Products, especially according to the requirements of your system. Before purchasing WEH® Products, please particularly ensure that our products are compatible with your intended use, your performance data, your material and fluids, your system concept and your system limits according to our product specifications. Please also consider your technical and legal requirements for operation, handling and maintenance. The quality and safety of WEH® Products is our highest priority. For this reason, WEH® Products may not be used outside the specifications in the relevant data sheets and product descriptions. If you are not sure whether the WEH® Product is suitable for your system and intended use, please contact us in advance. We also strongly recommend that you refrain from using third-party spare parts or a combination of WEH® Products with unsuitable third-party products. You alone are responsible for reviewing the suitability of third-party products. WEH® Products and WEH® Spare parts comply with our quality and safety standards.
Explanation on the Pressure Equipment Directive	In general, WEH® Products with a maximum allowable operating pressure of more than 0.5 bar (PS) fall within the scope of application of the Pressure Equipment Directive 2014/68/EU, are generally classified as pressure accessories in accordance with Article 2 (5) of the same and are considered to be similar to piping. These WEH® Products may not be used as safety accessories. Furthermore, it is pointed out, that these WEH® Products are designed and placed on the market in accordance with the requirements of Article 4 (3) of the Pressure Equipment Directive 2014/68/EU. For some products a different classification and/or categorisation is required or can be conducted on request. In these cases, if legally required, a conformity assessment procedure in accordance with Annex III of the Pressure Equipment Directive 2014/68/EU can and will also be conducted and the conformity can be declared by means of an EU Declaration of Conformity in accordance with Annex IV of the Pressure Equipment Directive 2014/68/EU. In these cases, the EU Declaration of Conformity is enclosed with the product.
External change management	WEH reserves the right to update, optimise and adjust its products continuously. This may result in corresponding changes of the product. Customers will be informed proactively or unsolicited by WEH only in individual cases about product updates, product optimisations and/or product adaptations that have been carried out. You are free to contact WEH at any time to request information about any product updates, product optimisations and/or product adjustments.

» Brochure data

This catalog was created diligently and on the basis of decades of experience.

All information/recommendations in this catalog are non-binding and are particularly subject to possible deviations or changes. For any binding information/recommendations, please refer to the verified information/recommendations in our individual orders. Particularly, due to the wide range of possible applications of WEH® Products and the unknown parameters and operating conditions linked to them, the accuracy and/or completeness of the information/recommendations in this catalog cannot be guaranteed with respect to certain individual cases. In doing so, we would like to refer once again to the information/recommendations provided in individual orders.

The application limits indicated in this catalog (e.g. for pressure, temperature, etc.) are generally theoretical values determined in a test environment. As the concrete operating conditions could differ, we cannot ensure that these values apply to a specific customer application. During the practical use, you should particularly consider that the mutual influence of operational parameters could result in changes of the maximum values. Especially, in case of any unusual operating conditions, please contact WEH before using any WEH® Products. We therefore strongly recommend that you also require any necessary binding information/recommendations to be included by us in the individual orders.

Furthermore, we point out that we cannot assume any warranty or accept any responsibility for printing errors, incomplete information or misinterpretations. Illustrations and/or images are particularly provided for illustrative purposes only and may differ in some details from the actual product. Moreover, dimensions and other technical details in this catalog are non-binding information and are provided for illustrative purposes only. The product's exact form and design result exclusively from the specific individual order. In particular, certain information/recommendations in the catalog only become integral part of the contract if they have been expressly contractually agreed.

Only the latest version of our catalog and other product related documents is valid and applicable. Please ensure that you always use the latest catalog's and documents' versions. Please feel free to contact WEH at any time and request the latest versions.

Our General Terms and Conditions and the Agreement on Protection of Know-How and Quality Assurance shall apply to deliveries and other services, unless expressly agreed otherwise.

In principle, we do not accept the General Terms and Conditions of our customers or third parties. Thank you for your understanding.

WEH GmbH Verbindungstechnik
Josef-Henle-Str. 1
89257 Illertissen / Germany

Phone: +49 7303 95190 704
E-Mail: h2-cng@weh.com
Website: www.weh.com

More questions? – Great! Don't hesitate to contact our experts.