

baromax

Ultra high-pressure solutions

Components and systems for fluid technology



© All rights reserved, WEH GmbH Verbindungstechnik.

Any unauthorized copying, distribution or other use of the copyrighted content is strictly forbidden without the written consent of WEH GmbH Verbindungstechnik.

Upon transmission of a newer version of this document, all previous versions are no longer valid. In principle, the latest version of the document is valid. This can be found at www.weh.com.

Our General Terms and Conditions and the Agreement on Protection of Know-How and Quality Assurance (www.weh.com) shall apply to deliveries and other services, unless expressly agreed otherwise.

We do not accept any General Terms and Conditions of the purchaser.

WEH® is a registered trademark of WEH GmbH Verbindungstechnik.

» Table of Contents

1 Overview	4
1.1 General Overview	4
1.2 Product Overview and Applications	5
1.3 Technical Product Overview	6
2 Fittings and Pipelines	8
3 Check Valves	16
4 Valves	18
4.1 baromax Hand Valve	19
5 Pressure Vessels and Pressure Generators	22
5.1 baromax Pressure Vessels	23
5.2 baromax Spindle Pumps	24
6 Systems and Plants	26
7 Tools	27
8 Further Information	28
8.1 Technical Appendix	28
8.2 Brochure Data	31

» General Overview

New dimensions at WEH:

We now offer a range up to 10,000 bar



For more than 50 years, we have been renowned internationally for our **expertise in high pressure**. This skill has now achieved new dimensions: By purchasing the product portfolio of baromax GmbH, we are now able to offer the pressure range of **up to 10,000 bar**. This **expansion of our portfolio** sends a positive signal to our customers and interested parties.

Omar Hakam (founder of baromax, pictured on the left) is excited to accompany WEH and Managing Director **Anton Halbich** (pictured on the right) during the market introduction and following stages. WEH is growing. Under the name „baromax“, we offer **components, systems and services for applications in the ranges from 1,000 to 10,000 bar**.

We offer nearly all components for the construction of high pressure plants here and also develop **individual solutions and complete systems** on request.

The components we deliver include:

- Fittings
- Valves
- Tubes and hoses
- Pressure generators
- Pressure vessels

A successful match!

WEH and baromax: An interview with pressure experts

Mr. Hakam, you were looking for a company that would acquire your product portfolio and scale up the business. Why was it a perfect fit between baromax and WEH?

Omar Hakam: There are various aspects that work together wonderfully. On the one hand there's the technical side, that is, the experience with pressure devices that WEH contributes, since the company has been successful in this field for many decades.

The other aspect is the human factor. WEH is a family-run mid-sized company, which means that we came to a mutual understanding very quickly on this personal level.

Now the range has been extended up to 10,000 bar. Would you mind explaining these dimensions to us, Mr. Hakam?

Omar Hakam: The easiest way is to illustrate this using examples: In the area of pneumatics, the pressure involved is generally 6 to 8 bar. These are values we know from the workshop. For hydraulics, like what we have on excavators for example, we're talking about dimensions from 250 to 400 bar. If you need to cut metals, that already takes 2,000 to 4,000 bar. Everything above that is really a special application. Pressures of 10,000 bar are dimensions that really only occur naturally in geological formations.

Mr. Halbich, how do these ultra high pressure products fit with WEH and in your portfolio?

Anton Halbich: We have always dealt with high tech and the highest level of engineering expertise. We see pressure as our future. Or more precisely, high pressure and the ultra-high pressure range. That's why baromax is a very good fit for us. We are able to expand our existing customer base: Horizontally, that is, with components, systems and plants, as well as vertically. This means offering new products in new pressure ranges. We are really made for each other. Well, maybe we were also looking for one another.

» Product Overview

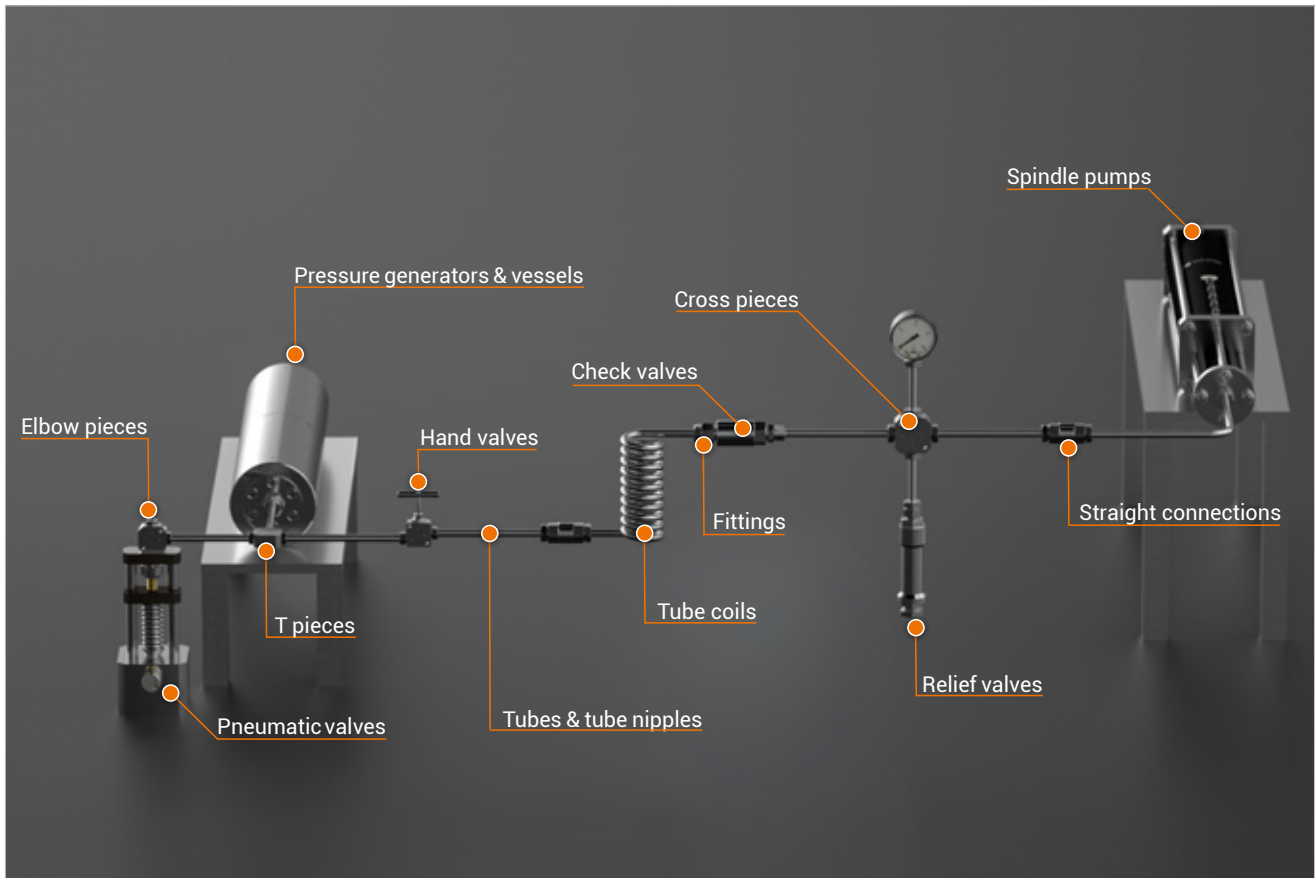

Applications and Industries

The baromax high pressure systems are in demand everywhere **media needs to be stored and moved under high pressure up to 10,000 bar.**

With our solutions in this field, we supply numerous customers from a variety of sectors such as general industry, mechanical engineering, companies operating for and/or with test facilities, or research institutions.

Typical applications for such high pressure systems include:

- Hydroforming
- Isostatic presses
- Water jet technology
- High pressure treatment of food
- Test stands for pressure and leak testing
- Plants in the petrochemical and mining sector
- ...and lots more



» Technical Product Overview

PRESSURE RANGES

WEH's baromax **ultra high pressure components** are designed for maximum operating pressures of 2,500, 4,200, 7,000 or 10,000 bar.

PIPELINE SIZES

Pipelines are offered in the **standard sizes** 1/4", 3/8" and 9/16" (external diameter). The following standard nominal bores are available according to the pressure range:

Nominal Bore (mm)	Nominal Pressure (bar)	External Tube Diameter
1.6	7,000	1/4"
	10,000	3/8"
2.3	4,200	1/4"
3.2		3/8"
4.8		9/16"
8.0	2,500	

For tube processing by customers, WEH® offers an **extensive range of tools**. We are also happy to supply you with tubes that are already preparing for fittings (tube nipple).

THREAD TYPES

Fittings for screw connection are available both with **metric** and with **imperial threads**. For more details, see the chapter "fittings and lines".

MEDIA

Ultra high pressure baromax components are designed in their standard versions for use with **air, water, and hydraulic oil**. Variants for other media are available on request.

» Technical Product Overview

ASSEMBLY OF HIGH PRESSURE TUBES

High pressure connections are composed of an **outer cone** which acts as a sealing surface, as well as a left-hand thread for attachment of the pressure ring. Inside the screw connection, an **inner cone** with a 2-5° larger angle is installed as a counterpart along with a female thread for the pressure screw.

When assembling high pressure tubes, the pressure screw must first be pushed onto the tube and then the pressure ring (note: left-hand thread) must be screwed onto the tube until **roughly 2 threads remain open from the cone** (Figure 2). As a result, the used thread length of the pressure screw is maximized (Figure 3) and the relief bores remain free. This is the only way to ensure safe operation.

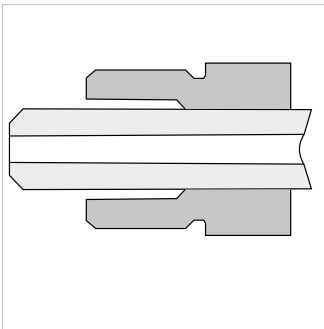

Figure 1

Push the pressure screw onto the clean tube.

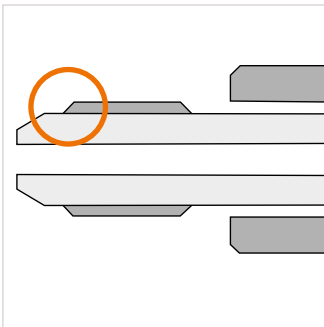

Figure 2

Screw the pressure ring onto the tube until roughly 2 threads remain open from the cone.

Attention: If the threads do not remain open, relief bores may be closed off. Safe operation is no longer ensured.

Push the pressure screw or other components onto the tube with pressure ring.

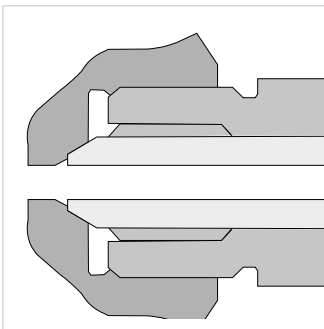

Figure 3

Screw the tube into the other components using a pressure screw.

If the tube needs to be bent, it must be ensured that the minimal bending radius should not fall below 5 times the external tube diameter, as otherwise the service life will be considerably shortened.

» baromax Fittings

DESCRIPTION



Features

- Pressure-resistant **up to 10,000 bar**
- Special sealing contour for **leak-free connection**
- **Optimized flow rate**, as nominal width of fittings is higher than that of tubes
- **Easy conversion/replacement** thanks to identical size of cross, T and angle piece

The baromax fittings ensure the leak-free connection of pipe components. The cone and thread fittings give you the good feeling of a simple and reliable fitting system. All fittings can be ordered individually or complete with the matching fittings. **The baromax high-pressure fittings are metal-to-metal sealed and can be connected multiple times - for pressure ranges up to 10,000 bar.** Ready for use for different media of fluid group 2 (according to DGR 2014/68/EU), such as air, water and hydraulic oil. Suitable for pipes in the standard market sizes 1/4", 3/8" and 9/16". Our fittings are available with both metric and imperial threads.

For the pressure ranges 2,500 bar and 4,200 bar, the fitting is manufactured using the **common global standard of a 58° outer cone in a 60° inner cone.**

For the pressure ranges 7,000 bar and 10,000 bar, we offer **special fitting.**

To attach the outer cone on the tube ends and for reworking or repair of the inner cone, WEH® offers all the **necessary tools.**

Applications

The baromax fittings are designed as a standard for **hydraulic high pressure systems.**

Typical applications include hydraulic systems in hydroforming and water jet plants, high-pressure test stands, isostatic pressure for manufacturing ceramics as well as high-pressure applications in chemistry and food processing.

TECHNICAL DATA

Characteristics	Basic Version	
Pressure ranges	PS = 2,500 bar, 4,200 bar, 7,000 bar, 10,000 bar (depending on design)	
Media	Air, Water, Hydraulic oil (exclusively non-hazardous oils pursuant to fluid group 2 DGR)	
Media Temperature Range	+5 °C up to +50 °C	
Material	High-strength stainless steel	
Conformity / Tests / Approvals	Pressure equipment type	Pipe-like, pressure-retaining equipment in accordance with Article 2, No. 5 of the Pressure Equipment Directive
	Classification	Article 4, paragraph 3

Other Designs on Request

» baromax Fittings

ORDERING | Straight Connection

Straight connections with **two identical ports**, available with all common high-pressure connection sizes. With two **diagonally arranged mounting bores**. The identical pattern of holes on angle, T, and cross pieces facilitates any future conversions and expansions of the pipe system.

Special designs with different connection threads or for deviating pressure ranges are available on request. Special materials for **challenging media or conditions** of use are available on request.

approx. dimensions (mm)

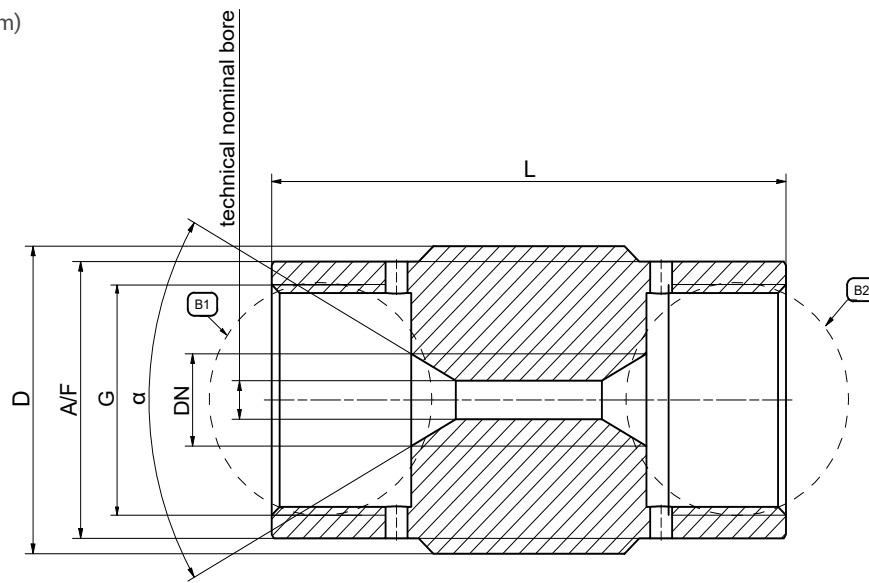

Part No.	BG	Product Series	Pressure (PS)	Nominal Bore (DN)	Technical Nominal Bore	External Tube Diameter	Thread (G) (B1 = B2)	α	D	L	A/F
C1-185527	1	FT-F2-S1	2,500 bar	5.0	2.8	1/4"	M16x1,5	60 °	25.0	40.0	22.0
C1-185681	1	FT-F2-S1	2,500 bar	5.0	2.8	1/4"	9/16"-18 UNF	60 °	25.0	40.0	22.0
C1-185685	2	FT-F2-S1	2,500 bar	8.0	5.0	3/8"	M20x1,5	60 °	32.0	48.0	27.0
C1-185689	2	FT-F2-S1	2,500 bar	8.0	5.0	3/8"	3/4"-16 UNF	60 °	32.0	48.0	27.0
C1-185506	3	FT-F2-S1	2,500 bar	12.0	8.0	9/16"	M30x2	60 °	40.0	70.0	36.0
On request	3	FT-F2-S1	2,500 bar	12.0	8.0	9/16"	1 1/8"-12 UNF	60 °	40.0	70.0	36.0
C1-185526	1	FT-F2-S2	4,200 bar	5.0	2.8	1/4"	M16x1,5	60 °	25.0	40.0	22.0
C1-184929	1	FT-F2-S2	4,200 bar	5.0	2.8	1/4"	9/16"-18 UNF	60 °	25.0	40.0	22.0
C1-185682	2	FT-F2-S2	4,200 bar	8.0	3.3	3/8"	M20x1,5	60 °	32.0	48.0	27.0
C1-185671	2	FT-F2-S2	4,200 bar	8.0	3.3	3/8"	3/4"-16 UNF	60 °	32.0	48.0	27.0
C1-185505	3	FT-F2-S2	4,200 bar	12.0	5.0	9/16"	M30x2	60 °	40.0	70.0	36.0
C1-185690	3	FT-F2-S2	4,200 bar	12.0	5.0	9/16"	1 1/8"-12 UNF	60 °	40.0	70.0	36.0
On request	1	FT-F2-S3	7,000 bar	--	2.0	1/4"	M16x1,5	120 °	25.0	40.0	22.0
On request	1	FT-F2-S3	7,000 bar	--	2.0	1/4"	9/16"-18 UNF	120 °	25.0	40.0	22.0
On request	1	FT-F2-S4	10,000 bar	--	2.0	1/4"	M16x1,5	120 °	25.0	40.0	22.0
On request	1	FT-F2-S4	10,000 bar	--	2.0	1/4"	9/16"-18 UNF	120 °	25.0	40.0	22.0
On request	2	FT-F2-S4	10,000 bar	--	2.0	3/8"	M20x1,5	120 °	32.0	48.0	27.0
On request	2	FT-F2-S4	10,000 bar	--	2.0	3/8"	3/4"-16 UNF	120 °	32.0	48.0	27.0

» baromax Fittings

ORDERING | Elbow Piece

Elbow pieces with **two identical ports**, available with all common high-pressure connections. With two **diagonally arranged mounting bores**. The identical pattern of holes on angle, T, and cross pieces facilitates any future conversions and expansions of the pipe system.

Special designs with different connection threads or for deviating pressure ranges are available on request. Special materials for **challenging media or conditions** of use are available on request.

approx. dimensions (mm)

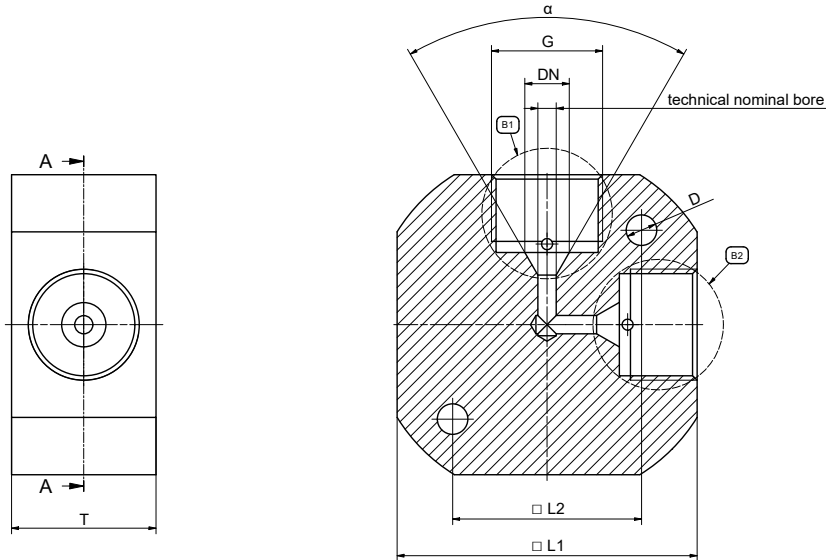

Part No.	BG	Product Series	Pressure (PS)	Nominal Bore (DN)	Technical Nominal Bore	External Tube Diameter	Thread (G) (B1 = B2)	α	Wide/Height (L1)	Depth (T)	Distance Mounting Bores (L2)	D
C1-185375	1	FT-F1-S1	2,500 bar	5.0	2.8	1/4"	M16x1,5	60°	40.0	22.0	26.0	5.5
C1-185178	1	FT-F1-S1	2,500 bar	5.0	2.8	1/4"	9/16"-18 UNF	60°	40.0	22.0	26.0	5.5
C1-185711	2	FT-F1-S1	2,500 bar	8.0	5.0	3/8"	M20x1,5	60°	48.0	27.0	34.0	5.5
On request	2	FT-F1-S1	2,500 bar	8.0	5.0	3/8"	3/4"-16 UNF	60°	48.0	27.0	34.0	5.5
C1-185715	3	FT-F1-S1	2,500 bar	12.0	8.0	9/16"	M30x2	60°	70.0	36.0	48.0	6.5
C1-185716	3	FT-F1-S1	2,500 bar	12.0	8.0	9/16"	1 1/8"-12 UNF	60°	70.0	36.0	48.0	6.5
C1-185338	1	FT-F1-S2	4,200 bar	5.0	2.8	1/4"	M16x1,5	60°	40.0	22.0	26.0	5.5
C1-185372	1	FT-F1-S2	4,200 bar	5.0	2.8	1/4"	9/16"-18 UNF	60°	40.0	22.0	26.0	5.5
C1-185584	2	FT-F1-S2	4,200 bar	8.0	3.3	3/8"	M20x1,5	60°	54.0	26.0	34.0	5.5
C1-185710	2	FT-F1-S2	4,200 bar	8.0	3.3	3/8"	3/4"-16 UNF	60°	54.0	26.0	34.0	5.5
C1-180995	3	FT-F1-S2	4,200 bar	12.0	5.0	9/16"	M30x2	60°	70.0	36.0	48.0	6.5
C1-185631	3	FT-F1-S2	4,200 bar	12.0	5.0	9/16"	1 1/8"-12 UNF	60°	70.0	36.0	48.0	6.5
On request	1	FT-F1-S3	7,000 bar	--	2.0	1/4"	M16x1,5	120°	40.0	22.0	26.0	5.5
On request	1	FT-F1-S3	7,000 bar	--	2.0	1/4"	9/16"-18 UNF	120°	40.0	22.0	26.0	5.5
On request	1	FT-F1-S4	10,000 bar	--	2.0	1/4"	M16x1,5	120°	40.0	22.0	26.0	5.5
On request	1	FT-F1-S4	10,000 bar	--	2.0	1/4"	9/16"-18 UNF	120°	40.0	22.0	26.0	5.5
On request	2	FT-F1-S4	10,000 bar	--	2.0	3/8"	M20x1,5	120°	48.0	27.0	34.0	5.5
On request	2	FT-F1-S4	10,000 bar	--	2.0	3/8"	3/4"-16 UNF	120°	48.0	27.0	34.0	5.5

» baromax Fittings

ORDERING | T Piece

T pieces with **three identical ports**, available with all common high-pressure connection sizes.

With two **diagonally arranged mounting bores**. The identical pattern of holes on angle, T, and cross pieces facilitates any future conversions and expansions of the pipe system.

Special designs with different connection threads or for deviating pressure ranges are available on request. Special materials for **challenging media or conditions** of use are available on request.

approx. dimensions (mm)

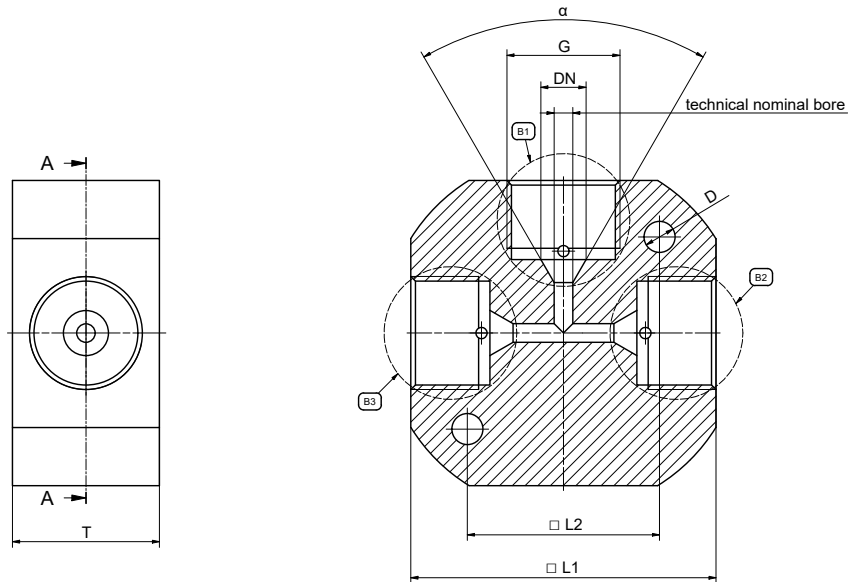

Part No.	BG	Product Series	Pressure (PS)	Nominal Bore (DN)	Technical Nominal Bore	External Tube Diameter	Thread (G) (B1 = B2 = B3)	α	Wide/Height (L1)	Depth (T)	Distance Mounting Bores (L2)	D
C1-185344	1	FT-F1-S1	2,500 bar	5.0	2.8	1/4"	M16x1,5	60 °	40.0	22.0	26.0	5.5
C1-185180	1	FT-F1-S1	2,500 bar	5.0	2.8	1/4"	9/16"-18 UNF	60 °	40.0	22.0	26.0	5.5
C1-186016	2	FT-F1-S1	2,500 bar	8.0	5.0	3/8"	M20x1,5	60 °	48.0	27.0	34.0	5.5
C1-186017	2	FT-F1-S1	2,500 bar	8.0	5.0	3/8"	3/4"-16 UNF	60 °	48.0	27.0	34.0	5.5
C1-185985	3	FT-F1-S1	2,500 bar	12.0	8.0	9/16"	M30x2	60 °	70.0	36.0	48.0	6.5
C1-185987	3	FT-F1-S1	2,500 bar	12.0	8.0	9/16"	1 1/8"-12 UNF	60 °	70.0	36.0	48.0	6.5
C1-185350	1	FT-F1-S2	4,200 bar	5.0	2.8	1/4"	M16x1,5	60 °	40.0	22.0	26.0	5.5
C1-185361	1	FT-F1-S2	4,200 bar	5.0	2.8	1/4"	9/16"-18 UNF	60 °	40.0	22.0	26.0	5.5
C1-186014	2	FT-F1-S2	4,200 bar	8.0	3.3	3/8"	M20x1,5	60 °	54.0	26.0	34.0	5.5
C1-186015	2	FT-F1-S2	4,200 bar	8.0	3.3	3/8"	3/4"-16 UNF	60 °	54.0	26.0	34.0	5.5
C1-185983	3	FT-F1-S2	4,200 bar	12.0	5.0	9/16"	M30x2	60 °	70.0	36.0	48.0	6.5
C1-185986	3	FT-F1-S2	4,200 bar	12.0	5.0	9/16"	1 1/8"-12 UNF	60 °	70.0	36.0	48.0	6.5
On request	1	FT-F1-S3	7,000 bar	--	2.0	1/4"	M16x1,5	120 °	40.0	22.0	26.0	5.5
On request	1	FT-F1-S3	7,000 bar	--	2.0	1/4"	9/16"-18 UNF	120 °	40.0	22.0	26.0	5.5
On request	1	FT-F1-S4	10,000 bar	--	2.0	1/4"	M16x1,5	120 °	40.0	22.0	26.0	5.5
On request	1	FT-F1-S4	10,000 bar	--	2.0	1/4"	9/16"-18 UNF	120 °	40.0	22.0	26.0	5.5
On request	2	FT-F1-S4	10,000 bar	--	2.0	3/8"	M20x1,5	120 °	48.0	27.0	34.0	5.5
On request	2	FT-F1-S4	10,000 bar	--	2.0	3/8"	3/4"-16 UNF	120 °	48.0	27.0	34.0	5.5

» baromax Fittings

ORDERING | Cross Piece

Cross pieces with **four identical ports**, available with all common high-pressure connection sizes. With two **diagonally arranged mounting bores**. The identical pattern of holes on angle, T, and cross pieces facilitates any future conversions and expansions of the pipe system.

Special designs with different connection threads or for deviating pressure ranges are available on request. Special materials for **challenging media or conditions** of use are available on request.

approx. dimensions (mm)

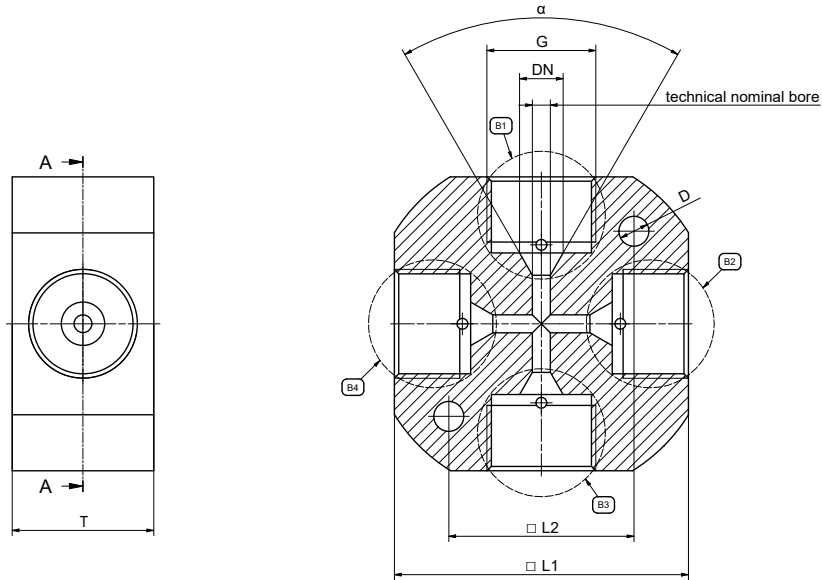

Part No.	BG	Product Series	Pressure (PS)	Nominal Bore (DN)	Technical Nominal Bore	External Tube Diameter	Thread (G) (B1 = B2 = B3 = B4)	α	Wide/ Height (L1)	Depth (T)	Distance Mounting Bores (L2)	D
C1-185383	1	FT-F1-S1	2,500 bar	5.0	2.8	1/4"	M16x1,5	60 °	40.0	22.0	26.0	5.5
C1-185171	1	FT-F1-S1	2,500 bar	5.0	2.8	1/4"	9/16"-18 UNF	60 °	40.0	22.0	26.0	5.5
C1-185756	2	FT-F1-S1	2,500 bar	8.0	5.0	3/8"	M20x1,5	60 °	48.0	27.0	34.0	5.5
C1-185177	2	FT-F1-S1	2,500 bar	8.0	5.0	3/8"	3/4"-16 UNF	60 °	48.0	27.0	34.0	5.5
C1-185729	3	FT-F1-S1	2,500 bar	12.0	8.0	9/16"	M30x2	60 °	70.0	36.0	48.0	6.5
C1-185755	3	FT-F1-S1	2,500 bar	12.0	8.0	9/16"	1 1/8"-12 UNF	60 °	70.0	36.0	48.0	6.5
C1-185326	1	FT-F1-S2	4,200 bar	5.0	2.8	1/4"	M16x1,5	60 °	40.0	22.0	26.0	5.5
C1-185379	1	FT-F1-S2	4,200 bar	5.0	2.8	1/4"	9/16"-18 UNF	60 °	40.0	22.0	26.0	5.5
C1-185629	2	FT-F1-S2	4,200 bar	8.0	3.3	3/8"	M20x1,5	60 °	54.0	26.0	34.0	5.5
C1-185753	2	FT-F1-S2	4,200 bar	8.0	3.3	3/8"	3/4"-16 UNF	60 °	54.0	26.0	34.0	5.5
C1-185728	3	FT-F1-S2	4,200 bar	12.0	5.0	9/16"	M30x2	60 °	70.0	36.0	48.0	6.5
C1-185754	3	FT-F1-S2	4,200 bar	12.0	5.0	9/16"	1 1/8"-12 UNF	60 °	70.0	36.0	48.0	6.5
On request	1	FT-F1-S3	7,000 bar	--	2.0	1/4"	M16x1,5	120 °	40.0	22.0	26.0	5.5
On request	1	FT-F1-S3	7,000 bar	--	2.0	1/4"	9/16"-18 UNF	120 °	40.0	22.0	26.0	5.5
On request	1	FT-F1-S4	10,000 bar	--	2.0	1/4"	M16x1,5	120 °	40.0	22.0	26.0	5.5
On request	1	FT-F1-S4	10,000 bar	--	2.0	1/4"	9/16"-18 UNF	120 °	40.0	22.0	26.0	5.5
On request	2	FT-F1-S4	10,000 bar	--	2.0	3/8"	M20x1,5	120 °	48.0	27.0	34.0	5.5
On request	2	FT-F1-S4	10,000 bar	--	2.0	3/8"	3/4"-16 UNF	120 °	48.0	27.0	34.0	5.5

» baromax Fittings

ACCESSORIES

The following **accessories** are available for the baromax fittings from WEH®:

Pressure Rings

Pressure rings for the fittings used in the high pressure area. In contrast to the competitors, our pressure rings are **not round on the outside, but instead feature a hexagonal wrench flat**. In this way, open-ended spanners can be used for installation and disassembly, which makes work considerably easier.

Our pressure rings are interchangeable with almost all common high pressure fittings.

The baromax pressure rings are manufactured using **stainless steel**.

approx. dimensions (mm)

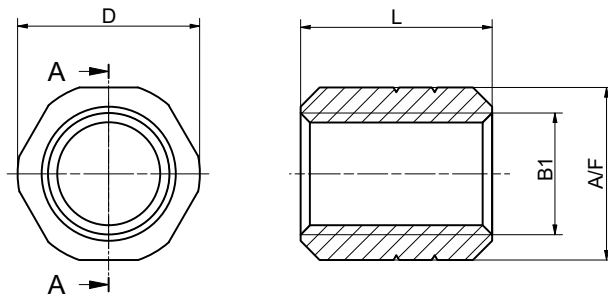

Part No.	Product Series	External Tube Diameter	Thread Size (B1)	Connection Types	L	A/F	D
C1-185394	FTZ-F3-S1	1/4"	1/4"-28 UNF LH	female thread	10.0	9.0	9.5
C1-185495	FTZ-F3-S1	3/8"	3/8"-24 UNF LH	female thread	13.5	12.0	12.7
C1-180993	FTZ-F3-S1	9/16"	9/16"-18 UNF LH	female thread	15.5	19.0	20.6

Pressure Screw

Pressure screws for the fittings used in the high pressure area. Our pressure screws are interchangeable with almost all common high pressure fittings.

For easier differentiation, our pressure screws are **specially marked on the wrench flat**: One groove for metric thread, and two grooves for imperial thread.

The baromax pressure screws are manufactured using **stainless steel**.

approx. dimensions (mm)

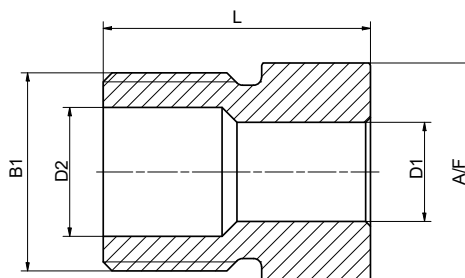

Part No.	Product Series	External Tube Diameter	Thread Size (B1)	Connection Types	D1	D2	L	A/F
C1-185522	FTZ-F1-S1	1/4"	M16x1,5	male thread	6.4	9.8	22.0	17.0
C1-185403	FTZ-F1-S1	1/4"	9/16"-18 UNF	male thread	6.4	9.8	22.0	17.0
C1-185521	FTZ-F1-S1	3/8"	M20x1,5	male thread	10.0	13.0	27.0	22.0
C1-185593	FTZ-F1-S1	3/8"	3/4"-16 UNF	male thread	10.0	13.0	27.0	22.0
C1-185588	FTZ-F1-S1	9/16"	M30x2	male thread	14.0	21.0	19.0	32.0
C1-185592	FTZ-F1-S1	9/16"	1 1/8"-12 UNF	male thread	14.0	21.0	19.0	32.0

» baromax Fittings

ACCESSORIES

Plug

Plugs for the fittings used in the high pressure area.
Our plugs are interchangeable with almost all common high pressure fittings.
The baromax plugs are manufactured using **stainless steel**.

approx. dimensions (mm)

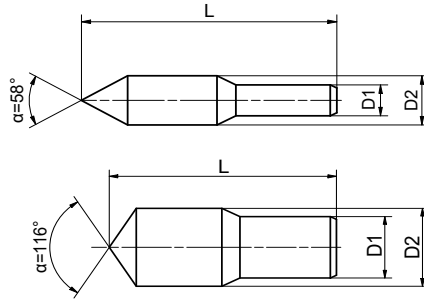

Part No.	Product Series	Pressure (PS)	External Tube Diameter	D1	D2	L	α
C1-185912	FTZ-F2-S1	2,500 bar + 4,200 bar	1/4"	6.4	9.5	34.0	58 °
C1-185918	FTZ-F2-S1	2,500 bar + 4,200 bar	3/8"	10.0	13.0	39.0	58 °
C1-185919	FTZ-F2-S1	2,500 bar + 4,200 bar	9/16"	14.0	20.6	48.0	58 °
On request	FTZ-F2-S1	7,000 bar + 10,000 bar	1/4"	6.4	9.5	31.0	116 °
On request	FTZ-F2-S1	7,000 bar + 10,000 bar	3/8"	10.0	13.0	36.0	116 °
On request	FTZ-F2-S1	7,000 bar + 10,000 bar	9/16"	14.0	20.6	44.0	116 °

» baromax Fittings

Tubes

The baromax high pressure tubes are manufactured from **seamless cold drawn stainless steel**.

approx. dimensions (mm)

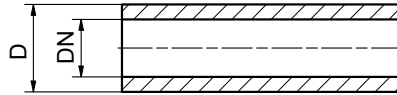

Part No.	Pressure (PS)	External Tube Diameter (D)	Nominal Bore (DN)
On request	2,500 bar	9/16"	8.0
On request	4,200 bar	1/4"	2.3
On request	4,200 bar	3/8"	3.2
On request	4,200 bar	9/16"	4.8
On request	7,000 bar	1/4"	1.6
On request	10,000 bar	3/8"	1.6

Special designs for deviating pressure ranges on request. Special materials for **challenging media or conditions** of use are available on request.



On request we can also offer you tube coils, tube nipples (tubes with prepared sealing cone) and hose lines.

» baromax Check Valves

DESCRIPTION



Features and Benefits

- **High flow rate** thanks to large nominal bores.
- **Easy installation** thanks to integrated double pressure screws with 1x left-hand and 1x right-hand thread.
- The check valve must be **tightened on just one wrench flat**, the tube is not subjected to any tension or rotation.

Wherever a medium needs to flow in **just one direction** within a pipeline system and return flow needs to be prevented, baromax check valves fulfil this function with **absolute reliability**.

Application

The baromax check valves are specially designed for high pressure ranges and are used particularly in hydroforming applications.

TECHNICAL DATA

Characteristics	Basic Version	
Max. operating pressure at B2	PS = 2,500 bar, 4,200 bar, 7,000 bar or 10,000 bar (depending on design)	
Max. inlet pressure at B1	800 bar	
Temperature range	+5 °C to +50 °C	
Materials	High-strength stainless steel	
Medium	Hydraulic oil (according to DGR fluid group 2)	
Conformity / Tests / Approvals	Pressure equipment type	Pipe-like, pressure-retaining equipment in accordance with Article 2, No. 5 of the Pressure Equipment Directive
	Classification	Article 4, paragraph 3

Designs for other media and temperature ranges are available on request

ORDERING | Check Valve

approx. dimensions (mm)

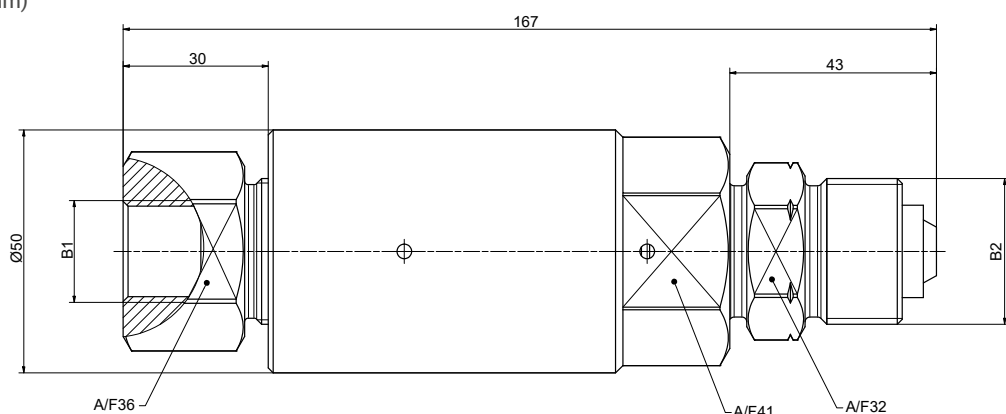

Part No.	Pressure (PS)	B1 (female thread)	B2 (male thread)	Nominal Bore (DN)
185446	4,200 bar	G 1/2-14	M30x2	8.0

Other connection types and sizes (e.g. Cone and Thread Fittings or VOSSLok40) on request.

» baromax Check Valves

ORDERING | Check Valve two-sided connections

approx. dimensions (mm)

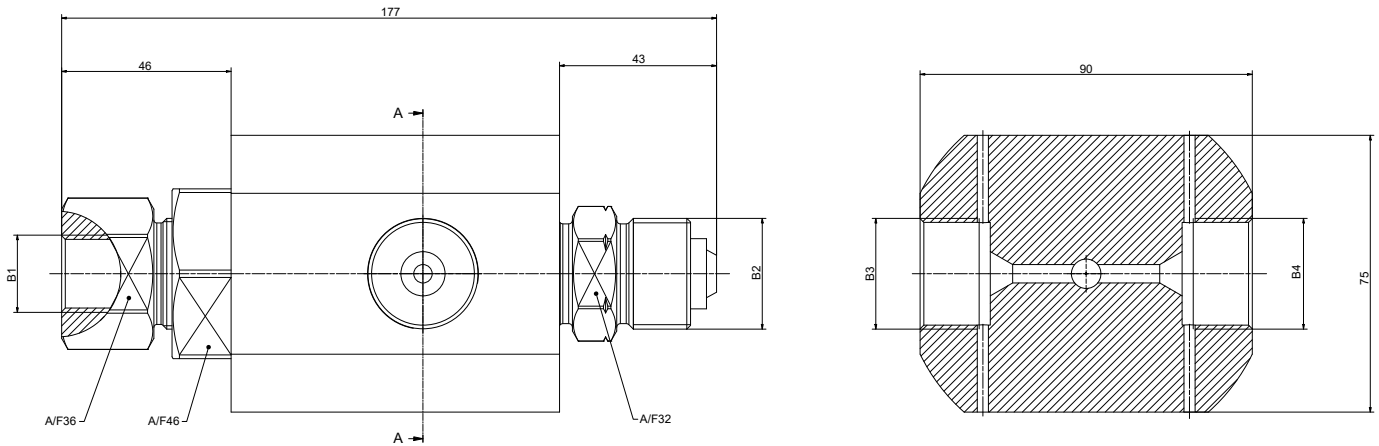

Part No.	Pressure (PS)	B1 (female thread)	B2 (male thread)	B3 (Innengewinde)	B4 (female thread)	Nominal Bore (DN)
185447	4,200 bar	G1/2-14	M30x2	M30x2	M30x2	8.0

Other connection types and sizes (e.g. Cone and Thread Fittings or VOSSLok40) on request.

» baromax Valves

Our baromax valve series offers maximum safety and reliability, even at pressure levels of up to 10,000 bar. Our product range includes hand valves, pneumatic valves, hydraulic valves and pressure relief valves.

The baromax valve series from WEH is designed for a wide range of applications and the highest safety requirements. Our high-pressure valves ensure optimum flow rates and effectively seal off liquid media. The pressure-resistant parts are made of high-quality, corrosion-resistant stainless steel. Each valve is supplied complete with screw connections. All baromax high-pressure valves undergo a strict end-of-line (EOL) test before delivery.

Hand Valves

Valves for opening and shutting off the media flow in high pressure applications. With a hand lever for manual actuation.



Pneumatic Valves

Like hand valves, but with compressed air ports for pneumatic actuation. Pneumatic or hydraulically powered valves are frequently also used as **safety valves**. In that case, the system is designed so that via a malfunction signal, the pneumatic or hydraulic system opens or closes the valve as needed.



Hydraulic Valves

Like hand valves, but with ports for hydraulic actuation.



Pressure Relief Valves

Pressure relief devices are used to strategically carry away excess media via a connected line.



» baromax Hand Valve

DESCRIPTION



Features and Benefits

- **Simple operation** via handle.
- **Easy installation** thanks to integrated pressure ring and pressure screw.
- Shut-off of the medium **is independent of direction**.
- **Straight or angled** design.

Wherever the medium needs to be shut off or opened manually in both directions within a pipe system, the baromax hand valves perform this function with **absolute reliability**.

Application

The baromax hand valves are specially designed for high pressure ranges and are used particularly in hydroforming applications.

TECHNICAL DATA

Characteristics	Basic Version	
Pressure ranges	PS = 2,500 bar, 4,200 bar (depending on design)	
Temperature range	+5 °C to +50 °C	
Materials	High-strength stainless steel	
Medium	Air / water / hydraulic oil	
Conformity / Tests / Approvals	Certified quality assurance system in accordance with the Pressure Equipment Directive 2014/68/EU	
	Pressure equipment type	Pipe-like, pressure-retaining piece of equipment
	Classification	Article 4, paragraph 3

Designs for other media and temperature ranges are available on request

» baromax Hand Valve

ORDERING | Hand Valve straight design

approx. dimensions (mm)

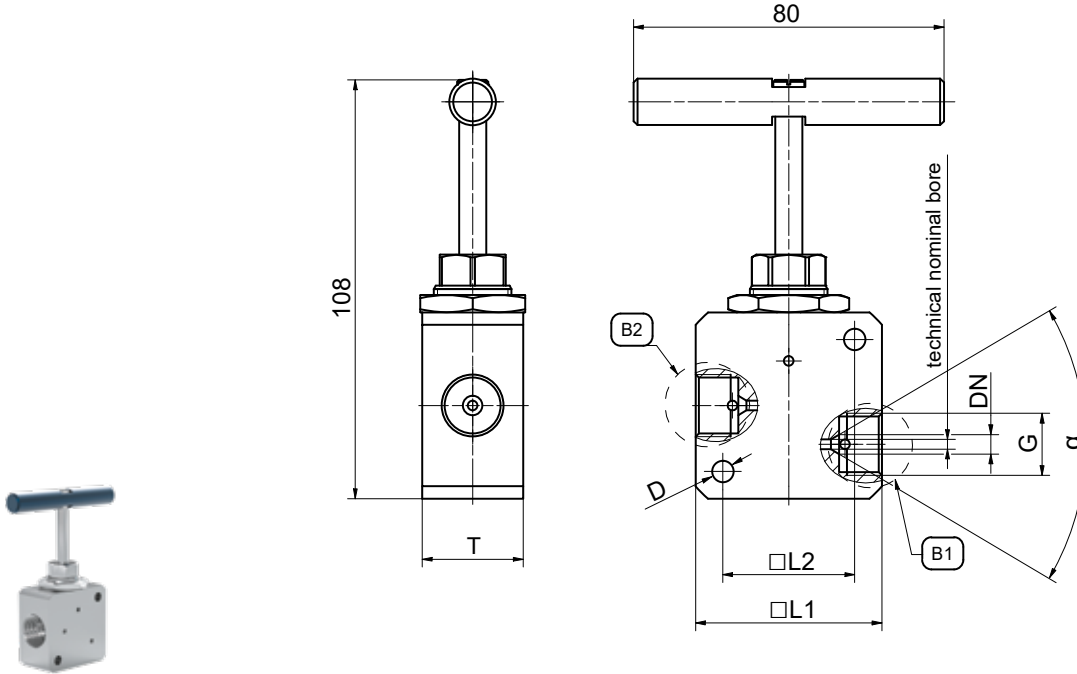

Part No.	Pressure (PS)	Nominal Bore (DN)	technical Nominal Bore	External Tube Diameter	Trhread (G) B1 = B2	α	Wide/ Height (L1)	Depth (T)	Distance Mounting Bores (L2)	D
C1-187301	4,200 bar	5.0	2.5	1/4"	M16x1.5	61 °	48.0	26.0	34,0	5.5

Other connection types and sizes (e.g. Cone and Thread Fittings or VOSSLok40) on request.

» baromax Hand Valve

ORDERING | Hand Valve angled design

approx. dimensions (mm)

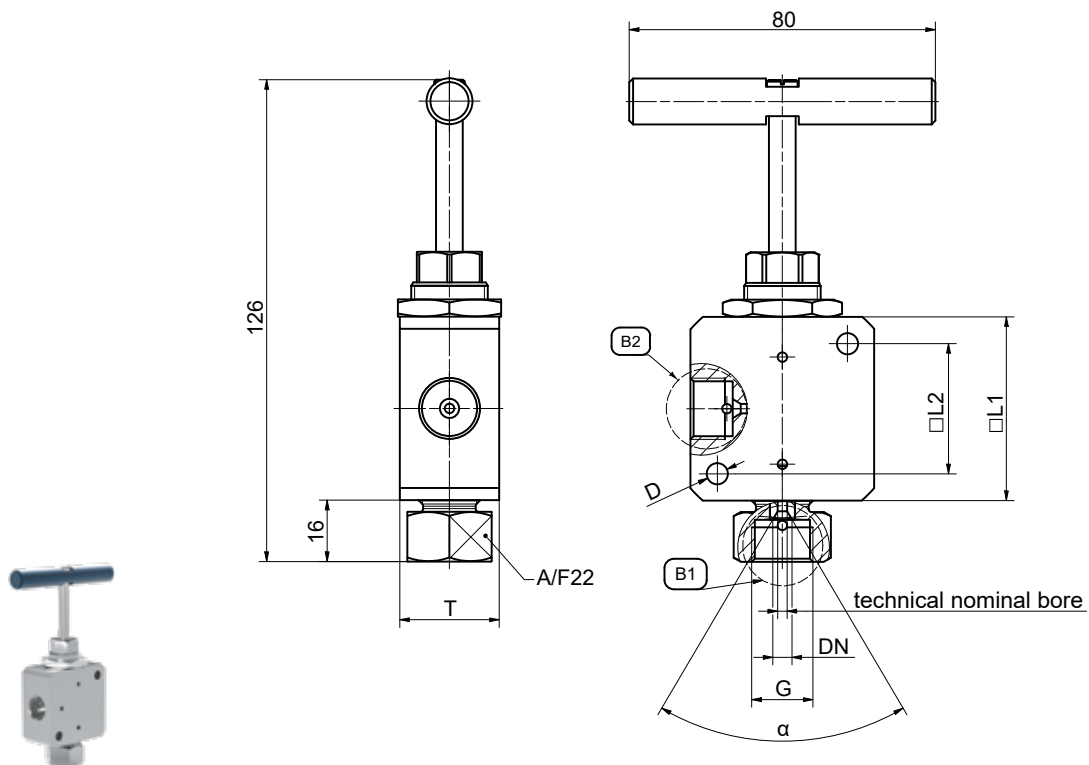

Part No.	Pressure (PS)	Nominal Bore (DN)	technical Nominal Bore	External Tube Diameter	Thread (G) B1 = B2	α	Wide/ Height (L1)	Depth (T)	Distance Mounting Bores (L2)	D
C1-186219	4,200 bar	5.0	2.5	1/4"	M16x1.5	61 °	48.0	26.0	34,0	5.5

Other connection types and sizes (e.g. Cone and Thread Fittings or VOSSLok40) on request.

» baromax Pressure Vessels and Pressure Generators

For your high pressure system, we supply pressure generators and pressure accumulators that are **individually tailored** to your application and your needs.

Pressure Vessels

Fluids are stored under pressure in pressure vessels. When unloading, energy can be generated with the vessel as a result. Pressure vessels take on the emergency function of dampening vibrations and compensating for leaked oil. Many other applications are possible.



Autoclaves

These pressure vessels with integrated spindle pump are suitable for thermal treatment of media or the examination of chemical processes in the high pressure range.



Hand Spindle Pumps

Hand spindle pumps are used if a suitable, cost-effective yet precise option is needed to generate higher pressures with small volumes.



Electrical Spindle Pumps

Compared with other forms of pressure generation, electrical spindle pumps offer the advantage of very precise control and guidance. Depending on the application and the available measuring technology, the pressure and volumetric flow can be finetuned.



Pneumatic Pressure Transducers

Pressure transducers are used to increase the pressure of fluid media and gases and are implemented if high pressures are needed for specific functions but the overall plant is not designed for that purpose.



Hydraulic Pressure Transducers

The use and application are the same as for pneumatic pressure transducers, but instead of a compressed air system, the drive is a intermediate pressure hydraulic system with approx. 200 to 450 bar.



► **Didn't find the right product at first glance?** We are happy to offer you suitable components for your high pressure system on request. Please tell us the application, the required max. operating pressure, connection sizes, temperature ranges, required volume and media used.

✉ sales@weh.com

» baromax Pressure Vessel

DESCRIPTION



Features and Benefits

- **Flexible design**
Can be installed in any position.
- **Secure storage / fixing** is guaranteed.
- Simple installation

Pressure vessels store fluids under high pressure. This allows energy to be extracted from the reservoir during discharge. Pressure vessels are used for emergency functions, damping vibrations and compensating for oil leaks, among other things.

Depending on the application, these tanks can be equipped with various additional functions, such as an integrated spindle pump for precise pressure control or as a reaction tank for carrying out processes under controlled conditions.

Application

The baromax vessels are specially designed for high pressure ranges and are used particularly in hydroforming applications.

TECHNICAL DATA

Characteristics	Basic Version	
Pressure ranges	PS = 700 bar, 1,500 bar, 3,000 bar (depending on design)	
Temperature range	0 °C up to +50 °C	
Materials	High-strength stainless steel	
Medium	Water / glycol	
Conformity / Tests / Approvals	Pressure equipment type	Vessels according to Article 2, No. 2 of the Pressure Equipment Directive
	Classification	Article 4, paragraph 3

Designs for other media and temperature ranges are available on request

ORDERING

approx. dimensions (mm)

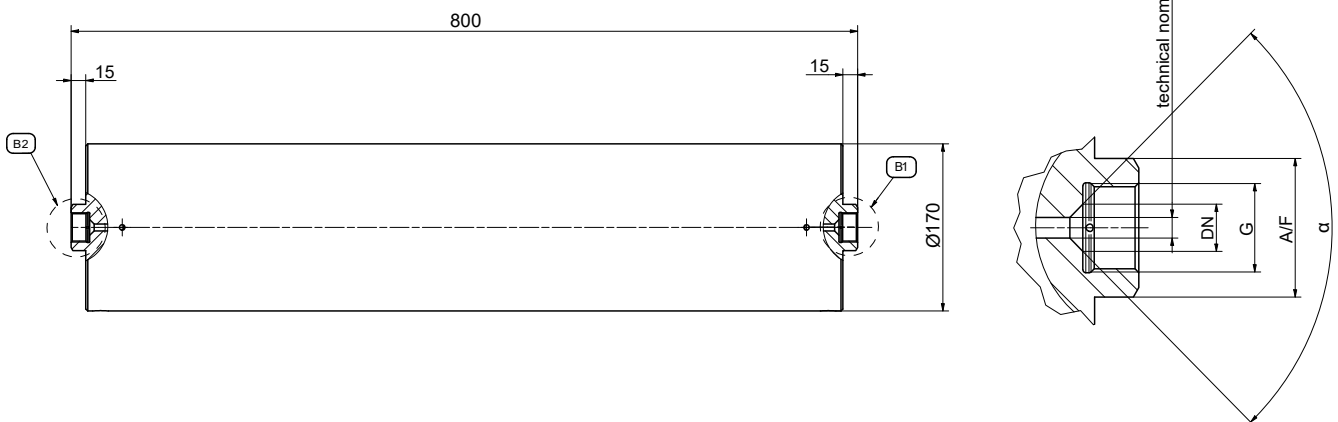

Part No.	Nominal Bore (DN)	Technical Nominal Bore	Pressure (PS)	Thread (G) B1 = B2	A/F	α
186688	16	7	1,500 bar	M30x2	41	91 °
180792	16	7	3,000 bar	M30x2	41	90 °

Other connection types and sizes (e.g. Cone and Thread Fittings or VOSSLok40) on request.

» baromax Spindle Pumps

DESCRIPTION



Features and Benefits

- **Robust, slim** design
- Made of high-quality steel
- Low maintenance
- **Easy** to install
- Good accessibility to all connections
- **High** variance in drive design

The baromax hand spindle pumps are particularly suitable as pressure generators for small mobile or stationary systems. The baromax hand spindle pumps can be used anywhere without compressed air or power supply. They offer a simple, cost-effective and yet precise way of generating high pressures with small volumes. In addition to the baromax hand spindle pumps, we also offer motor-driven spindle pumps, which have the advantage of very precise control and controllability.

Depending on the application and the measurement technology available, the pressure and flow rate can be finely adjusted with the baromax spindle pump.

Application

The baromax high-pressure pump systems are specially designed for high pressure ranges and are used particularly in hydroforming applications.

TECHNICAL DATA

Characteristics	Basic Version	
Pressure ranges	PS = 150 bar to 10,000 bar (depending on design)	
Stroke	1,500 cm ³ - 25 cm ³ (Pressure-dependent)	
Temperature range	+5 °C up to +50 °C	
Materials	High-strength stainless steel	
Medium	Liquid media (according to DGR fluid group 2)	
Conformity / Tests / Approvals	Pressure equipment type	Vessels according to Article 2, No. 2 of the Pressure Equipment Directive
	Classification	PS = 700 bar: Article 4, paragraph 3 PS = 2,000 bar: Module category I, incl. CE (pressure-dependent, volume-dependent)
	Condition	Liquid

Designs for other media and temperature ranges are available on request

» baromax Spindle pump

ORDERING

approx. dimensions (mm)

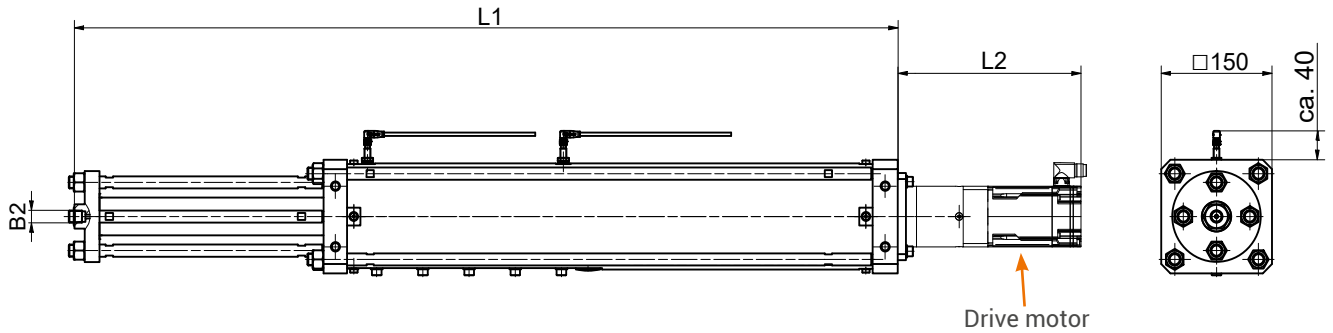

Part No.	Pressure (PS)	Stroke volumen (cm ³ / ml)	Nominal Bore (DN)	B2 (female thread)	L1	L2	Drive preparation	Media connection
180793	700 bar	120	16	NPT 3/8"	1125	6	Adapter plate for BG080	-
180791	2,000 bar	75	3	M16x1.5"	1115	175	Gearbox for NEMA34	90° pipe angle M16x1.5 AG
On request	Drive motor							

Other connection types and sizes (e.g. Cone and Thread Fittings or VOSSLok40) on request.

» baromax Systems

From small pneumatic aggregates all the way to large complete systems with multiple kinds of pressure generation, and a wide range of technical uses and controllers, we are able to offer you **custom solutions** for many requirements.

We supply high pressure systems predominantly for the following applications:

- Carfrettage plants
- Hydroforming plants
- Isostatic presses
- High pressure test benches
- Ultra high pressure homogenizers

► **Consult our product experts:** We are also your ideal contact for the implementation of high pressure systems for other applications.

✉ sales@weh.com



» baromax Tools

For tube processing, we offer you an **extensive range of tools**.

Thread Cutter

Hand tool for applying the thread for the pressure ring onto the tube ends. Depending on the tube diameter and thread type, different cutter inserts are available.



Cone Cutter

Hand tool for applying the conical sealing contour onto the tube ends. Depending on the tube diameter and cone angle, different cutter inserts are available.



Cone Reworker

During operation, plastic deformations may occur on tubes and fittings. With the cone reworker, the fittings can be reconditioned.



Tube Bender

Hand tool for manual bending of high pressure lines. Bending inserts are available for different tube sizes.



The following accessories are available for the baromax tool portfolio:

- Cutting blades
- Countersink
- Clamping jaws
- Thread-cutting dies
- Thread-cutting paste
- Glycol
- Hydraulic oil
- Freezing spray
- Leak detection spray

» Technical Appendix

Definitions

Abbreviation	Definition	
Pressure Specifications	<i>(all pressure specifications are to be understood as overpressure, unless otherwise stated)</i>	
PN	Nominal pressure	Nominal pressure after temperature compensation at 15 °C (59 °F)
PS	Max. allowable operating pressure	Maximum allowable operating pressure acc. to Pressure Equipment Directive 2014/68/EU, Article 2 paragraph 8
PT	Hydrostatic test pressure	Hydrostatic test pressure acc. to Pressure Equipment Directive 2014/68/EU, Annex I no. 7.4
PP	Pilot pressure	Actuation pressure for hydraulic and pneumatic components
PC	Cracking pressure	Pressure at which the check valve opens and the first indication of flow occurs
WP	Working pressure	'Working pressure' means the maximum pressure to which a component is designed to be subjected to and which is the basis for determining the strength of the component under consideration
MAWP	Max. allowable working pressure	Max. allowable operating pressure at which the weakest point of the system or the vessel (e.g. cylinder valve) can operate at a certain temperature during normal operation
Dimensions		
L1, L2, L3 ...	Length specification	
D1, D2, D3 ...	Diameter specification	
A/F(1), A/F(2) ...	Wrench size specification	
Ports		
A / X	Customer-specific port (test piece, sample, cylinder valve, handwheel respiratory protective equipment)	
B1, B2, B3 ...	Media ports	
C1, C2, C3 ...	Gas recirculation ports	
P1, P2, P3 ...	Pilot pressure ports	
MA1, MA2 ...	Measuring ports	
Q	Drain port filter	
G	Mounting bores	
Others		
DN	Nominal size (DN) acc. to Pressure Equipment Directive 2014/68/EU, whereby the largest, pressurized diameter of the media or pilot pressure connections of the WEH® Device (A, B1, B2, B3 or C1, C2, C3 and P1, P2, P3) which faces the customer's pipe system, is relevant.	
µm	Max. diameter of the filtered particle	
Kv	Is the discharge of water in m ³ /h at a pressure drop of 1 bar (14.5 psi), acc. to DIN/EN 60534-2	
Cv	Is the discharge of water in gallons per minute at a pressure drop of 1 psi, acc. to DIN/EN 60534-2	
IR	Infrared data interface	
ENR	Exchangeable data interface (exchangeable nozzle receiver)	

» Technical Appendix

Definitions

Abbreviation	Definition
TS	Maximum allowable temperature acc. to Pressure Equipment Directive 2014/68/EU, Article 2 paragraph 9
Breakaway force	Is the force range, in which the breakaway releases
NC	Normally closed (initial position of shut-off valve)
NO	Normally open (initial position of shut-off valve)

Technical explanations

Term	Definition
Temperature range	Is the temperature range in which the WEH® Product can be used. If no explicit information on medium and ambient temperature is given, this temperature range applies to both medium and environment.
Media temperature range	Is the temperature range of the medium used, which can flow through the WEH® Product (may change depending on the time of measurement).
Ambient temperature range	Is the temperature range of the environment in which the WEH® Product can be used.
Leak rate	Is the maximum external leak rate, which the WEH® Product exhibits in delivery condition.
Internal leak rate	The internal leak rate depends, among other things, on type of application, medium and pressure difference on the WEH® Product. On request it can be specified more precisely.
Max. side load	Is the max. allowable sum of all external forces that may act on the device under intended use. Note: External forces can affect the life time of WEH® Products and can cause damage. Tensile and transverse loads as well as vibrations and pressure impacts need to be considered, e.g. by user side measures such as on site mountings and similar. Therefore, lateral forces such as whipping hoses or other equipment must be avoided. WEH® Products should be installed in such a way, that lateral forces which could lead to leakage or damage can not occur. Special applications require a special consultation before selecting the product.
Products with pneumatic actuation	The customer has to ensure there is adequate axial movement when pneumatically actuated WEH® Products are used in automated systems, see maximum side load. Ideally the products should be mounted with a floating joint or introduced individually to prevent the possibly existing clamping jaws getting blocked or jammed in the thread of the test piece.
Sealing material	On request the WEH® Product can be adapted to customer specific applications regarding to the sealing materials used. The clarification of the media compatibility and suitability of the adapted WEH® Product for the final application is always the responsibility of the end user.
Corrosion resistant	WEH® Products are designed for use in temperate climate zones - with low levels of humidity and salinity in the air. An accelerated formation of rust or corrosion may occur at or near the sea. Therefore, reduce the inspection interval recommended for normal use and send in the WEH® Product for maintenance immediately if you notice increased soot, rust or corrosion.
Storage / life time of components	There are certain requirements for every WEH® Product. WEH® Products are generally products which may be subject to wear and fatigue during operation and depending on your individual application/use. For details - in particular regarding the corresponding minimum inspection and maintenance intervals – please refer to the respective operating instructions for the WEH® Product.

» Technical appendix

Further explanations

Subject	Definition
Technical data	Unless otherwise stated, the technical data in catalogs, data sheets and operating instructions are based on tests with nitrogen that are in the development phase or at the end of development. Leakage data are based on measurements with helium.
Intended use	For the intended use of WEH® Products, please refer to the respective operating instructions. The following applications are generally excluded for WEH® H ₂ and CNG products, unless these are expressly permitted in the operating instructions: <ul style="list-style-type: none"> • aerospace applications, e.g. in aircrafts • shipping applications • applications offshore and in littoral areas • applications within defense and weapons technology
Safe product selection	Our WEH® Products are designed to be operated by qualified professional users (insofar as WEH® Products are also designed to be operated by other users in individual cases, this is explicitly stated in the corresponding operating instructions). Please note that WEH does not know your system and therefore - also due to the large number of different potential applications of WEH® Products - cannot perform tests on all potential types of application. You alone are responsible for the selection, configuration and suitability of WEH® Products, especially according to the requirements of your system. Before purchasing WEH® Products, please particularly ensure that our products are compatible with your intended use, your performance data, your material and fluids, your system concept and your system limits according to our product specifications. Please also consider your technical and legal requirements for operation, handling and maintenance. The quality and safety of WEH® Products is our highest priority. For this reason, WEH® Products may not be used outside the specifications in the relevant data sheets and product descriptions. If you are not sure whether the WEH® Product is suitable for your system and intended use, please contact us in advance. We also strongly recommend that you refrain from using third-party spare parts or a combination of WEH® Products with unsuitable third-party products. You alone are responsible for reviewing the suitability of third-party products. WEH® Products and WEH® Spare parts comply with our quality and safety standards.
Explanation on the Pressure Equipment Directive	In general, WEH® Products with a maximum allowable operating pressure of more than 0.5 bar (PS) fall within the scope of application of the Pressure Equipment Directive 2014/68/EU, are generally classified as pressure accessories in accordance with Article 2 (5) of the same and are considered to be similar to piping. These WEH® Products may not be used as safety accessories. Furthermore, it is pointed out, that these WEH® Products are designed and placed on the market in accordance with the requirements of Article 4 (3) of the Pressure Equipment Directive 2014/68/EU. For some products a different classification and/or categorisation is required or can be conducted on request. In these cases, if legally required, a conformity assessment procedure in accordance with Annex III of the Pressure Equipment Directive 2014/68/EU can and will also be conducted and the conformity can be declared by means of an EU Declaration of Conformity in accordance with Annex IV of the Pressure Equipment Directive 2014/68/EU. In these cases, the EU Declaration of Conformity is enclosed with the product.
External change management	WEH reserves the right to update, optimise and adjust its products continuously. This may result in corresponding changes of the product. Customers will be informed proactively or unsolicited by WEH only in individual cases about product updates, product optimisations and/or product adaptations that have been carried out. You are free to contact WEH at any time to request information about any product updates, product optimisations and/or product adjustments.

» Brochure data

This catalog was created diligently and on the basis of decades of experience.

All information/recommendations in this catalog are non-binding and are particularly subject to possible deviations or changes. For any binding information/recommendations, please refer to the verified information/recommendations in our individual orders. Particularly, due to the wide range of possible applications of WEH® Products and the unknown parameters and operating conditions linked to them, the accuracy and/or completeness of the information/recommendations in this catalog cannot be guaranteed with respect to certain individual cases. In doing so, we would like to refer once again to the information/recommendations provided in individual orders.

The application limits indicated in this catalog (e.g. for pressure, temperature, etc.) are generally theoretical values determined in a test environment. As the concrete operating conditions could differ, we cannot ensure that these values apply to a specific customer application. During the practical use, you should particularly consider that the mutual influence of operational parameters could result in changes of the maximum values. Especially, in case of any unusual operating conditions, please contact WEH before using any WEH® Products. We therefore strongly recommend that you also require any necessary binding information/recommendations to be included by us in the individual orders.

Furthermore, we point out that we cannot assume any warranty or accept any responsibility for printing errors, incomplete information or misinterpretations. Illustrations and/or images are particularly provided for illustrative purposes only and may differ in some details from the actual product. Moreover, dimensions and other technical details in this catalog are non-binding information and are provided for illustrative purposes only. The product's exact form and design result exclusively from the specific individual order. In particular, certain information/recommendations in the catalog only become integral part of the contract if they have been expressly contractually agreed.

Only the latest version of our catalog and other product related documents is valid and applicable. Please ensure that you always use the latest catalog's and documents' versions. Please feel free to contact WEH at any time and request the latest versions.

Our General Terms and Conditions and the Agreement on Protection of Know-How and Quality Assurance shall apply to deliveries and other services, unless expressly agreed otherwise.

In principle, we do not accept the General Terms and Conditions of our customers or third parties. Thank you for your understanding.

Design and production

WEH GmbH Verbindungstechnik
Josef-Henle-Str. 1
89257 Illertissen / Germany

Phone: +49 7303 9609-0
E-Mail: sales@weh.com
Website: www.weh.com

More questions? – Great! Don't hesitate to contact our experts.